

Power Packs and Linear Drives for Autopilot



Lecomble & Schmitt s.A.s.

156 route de Briscous
64240 URT – France

Sales Department: 33 (0) 559 56 24 11 - commercial@ls-france.com

Technical Department: 33 (0) 559 56 26 46 - commercial2@ls-france.com

After Sales Service: 33 (0) 559 56 23 22 - commercial3@ls-france.com

Fax : 33 (0) 559 56 95 71

<https://www.ls-france.com>

CONTENTS

	Pages
• Introduction – Description	2
• Working Principle	3
• Selection of the System	4
• Different Types of Installations	5
• Power packs for Motorboats or Sailing Boats Equipped with Hydraulic Steering	
▪ Reversible Power Packs	6
▪ Power packs with Electrovalves	7
• Hydraulic Linear Drives for Sailing Boats Equipped with Mechanical Steering	
▪ Internal Installation with fixed flow.....	8 & 9
▪ Internal Installation with adjustable flow.....	10
▪ External Installation (cylinder only) with fixed flow	11
• Accessories	12
• Hydraulic Flexible Tubes	13
• Fittings	14
• Connection Kits for Raymarine, Simrad and Garmin Autopilots with LS Outboard Steering Systems	15
• Notes	
• Guarantee	

HYDRAULIC POWER PACKS AND LINEAR DRIVES FOR AUTOPILOTS

INTRODUCTION

LS power packs and linear drives for autopilots **are perfectly adapted to the requirements of different applications**, such as pleasure boating, workboats, professional or amateur fishing, competition and its accompaniment.

They **are easy to install**, state of the art machine finished and **made to resist a marine environment**.

You can easily select the best suited system for your boat within **the most comprehensive range** available on the market with a guarantee of **efficiency, reliability and security**.

Our systems carry a 2 year warranty. They are fully compatible with all brands of autopilots on the market today.

DESCRIPTION OF HYDRAULIC POWER PACKS AND LINEAR DRIVES FOR AUTOPILOTS

As a general rule, the basic set up of a hydraulic system for autopilot consists of:

- 1 hydraulic cylinder,
- 1 hydraulic power pack,
- Fittings and tubing to connect the cylinder to the power pack.

Other elements will be added to this basic set up in function of the configuration of the boat steering system – hydraulic steering, wire ropes, cables, etc.

Cylinder

The cylinder is the dictating element in the selection of a system. It gives the pushing power to the steering system in function of its effective area and the pressure it receives from the power pack. To select the cylinder, follow the method given in paragraph "Selection of the System".

Hydraulic Power Pack

Power packs are always composed of a reversible or non reversible electrical motor in 12 or 24 volts DC, or 220/240 V single-phased or three-phase, coupled to a reversible or non reversible axial piston pump or gear pump, with adjustable or fixed flow rate.

Receiving orders from the electronics, the power pack will suck or force back the oil in the circuit. The speed of correction is determined in function of the pump flow rate in litres per minute.

Our systems are fitted with lock valves which prevent cylinder movements once the boat is on the desired course until a new course correction is required.

Most of them are also fitted with pressure relief systems to protect the circuit against abnormal pressure increases.

Tubing

Tubing is designed for hydraulic oil transfer under pressure. Tubing diameter is selected in function of the power pack flow rate.

HYDRAULIC POWER PACKS AND LINEAR DRIVES FOR AUTOPILOTS

WORKING PRINCIPLE

When the boat moves away from the displayed course, the autopilot electronic computer sends current to the motor terminals or to the power pack electrovalve. Then, the cylinder will be supplied with oil and set in motion. As soon as the boat is back on the displayed course, the computer stops supplying the power pack and the cylinder stops moving.

• MOTORBOATS EQUIPPED WITH HYDRAULIC STEERING

- ① Manual pump
- ② Tubing
- ③ Power pack
- ④ By-pass valve
- ⑤ Cylinder
- ⑥ Tiller arm

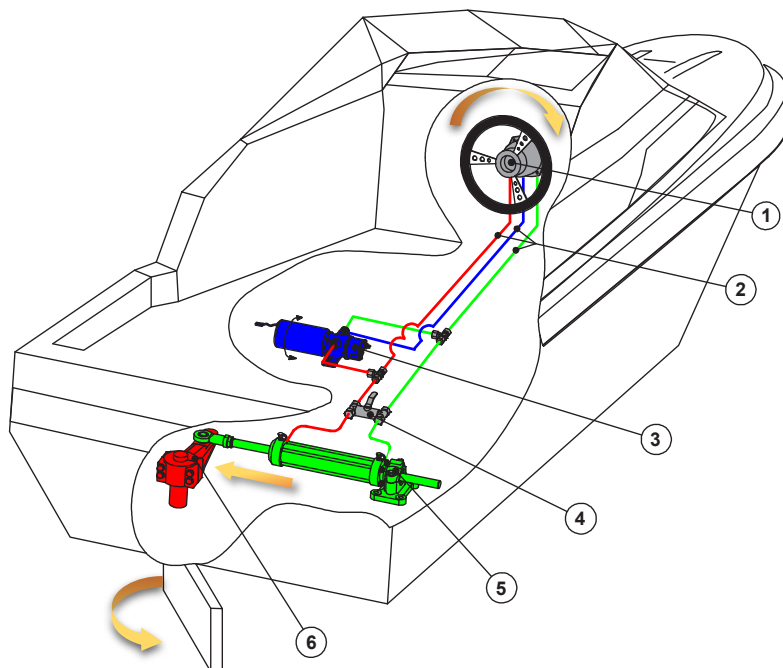

• SAILING BOATS EQUIPPED WITH WIRE ROPE STEERING

- ① Manual steering
- ② Quadrant
- ③ Linear cylinder
- ④ Rudder stock
- ⑤ Wire rope
- ⑥ Power pack

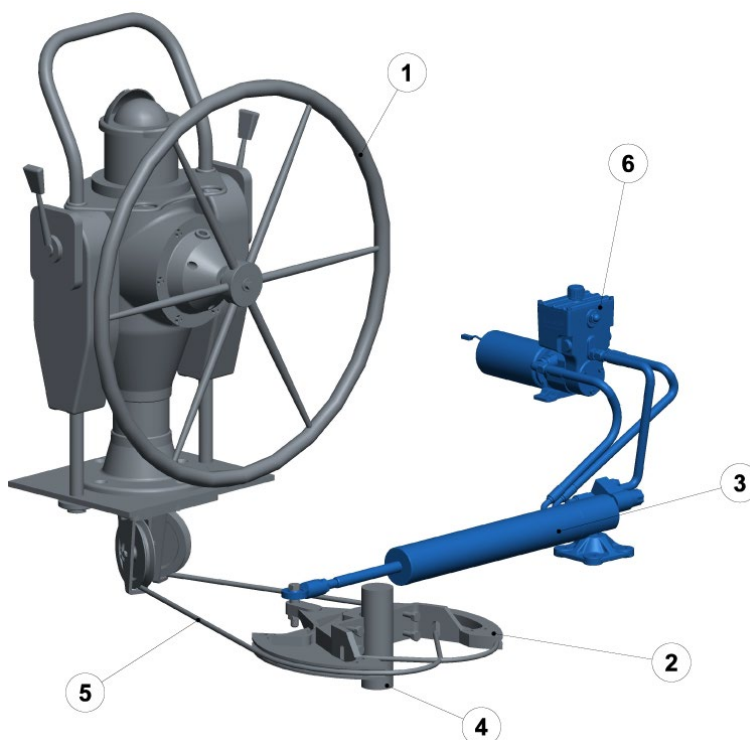

HYDRAULIC POWER PACKS AND LINEAR DRIVES FOR AUTOPILOTS

SELECTION OF THE SYSTEM

- **For boats equipped with a hydraulic steering**, it will be necessary to determine:
 - The volume of the steering cylinder (take the biggest volume in case of a single rod cylinder)
 - Available voltage on board (12 VDC, 24 VDC, etc.)

For planing or semi-planing hulls, the power pack will be selected in function of its flow rate so that the steering cylinder will run its complete stroke within 10 to 12 seconds.

For displacement hulls, the power pack flow rate must enable the steering cylinder to run its complete stroke within 15 to 17 seconds.

Examples :

🚤 **Speed boat, planing hull with a 239 cc cylinder – Available voltage 12 VDC**

$$\frac{60 \text{ seconds (1 minute)}}{12 \text{ seconds (required time)}} \times 0.239 \text{ litre (239 cc)} = \mathbf{1.195 \text{ litre / minute}}$$

The flow rate of the required power pack will be 1.19 litre / minute, therefore we will select a **reversible power pack with adjustable flow rate type RV2 (12 V) – page 6**

🚤 **Fishing or work boat, displacement hull with a 2,307 cc cylinder – Available voltage 24 VDC**

$$\frac{60 \text{ seconds (1 minute)}}{15 \text{ seconds (required time)}} \times 2.307 \text{ litres (2,307 cc)} = \mathbf{9.228 \text{ litres / minute}}$$

The flow rate of the required power pack will be around 9 litres / minute, therefore we will select a **power pack type HF 1.5 – 9 (24 V) – page 7**

- **For boats equipped with a mechanical steering (wire ropes, cables, rack and pinion)**, it will be necessary to determine:
 - The rudder(s) torque
 - The available voltage on board (12 VDC, 24 VDC, etc.)

Torque Calculation:

For boats fitted with a rudder with speed not exceeding 25 knots, the torque (**C**) of the rudder or rudders will be calculated according to the formula and correction coefficients below:

$$\mathbf{C = S \times [(0.4 Lg) - Lc] \times V^2 \times K}$$

- C** = Torque in kpm
S = Total surface of rudder (H x Lg) in sq. m
H = Height of rudder in m (metre)
Lg = Width of rudder in m (metre)
Lc = Compensation width in m (metre)
V = Maximum speed of the boat in knots
K = Coefficient according to total angle of rudder
- | | | |
|---------------------|-----|------------------|
| - Port to starboard | 70° | K = 15.89 |
| - Port to starboard | 80° | K = 17.80 |
| - Port to starboard | 90° | K = 19.52 |

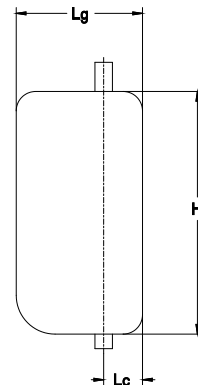

Corrections in function of the type of boat:

- For sailing-boats **C x 0.5**
- For boats fitted with several rudders (catamarans, trimarans, monohulls), multiply the calculated torque result by the number of rudders fitted on the boat.

Examples:

H = 1.2 m Speed under sail = 12 knots
 Lg = 0.7 m Speed with motor = 8 knots
 Lc = 0.18 S = 1.2 x 0.7 = 0.84 m²

Torque under sail = 0.84 x [(0.4 x 0.7) - 0.18] x 12² x 15.89 x 0.5 = **96.11 kpm**

Torque with motor = 0.84 x [(0.4 x 0.7) - 0.18] x 8² x 15.89 = **85.42 kpm**

Selection of the linear drive :

Torque not exceeding 50 kpm	Linear drive type 32ST16 NEWAVE	page 8
Torque not exceeding 100 kpm	Linear drive type 40ST16 NEWAVE	page 8
Torque not exceeding 200 kpm	Linear drive type 50ST20 NEWAVE	page 8
Torque not exceeding 390 kpm	Linear drive type 63ST28 DEBP NEWAVE	page 9

In the above example, the calculated torque is **96.11 kpm**. Therefore the correct selection will be a linear drive type **40ST16 NEWAVE**.

Note: for sailing boats with a modern hull and balanced rudder, the selection can be made in function of the boat length as below:

Length not exceeding 33 feet	Linear drive type 32ST16 NEWAVE*	page 8
Length not exceeding 44 feet	Linear drive type 40ST16 NEWAVE *	page 8
Length not exceeding 60 feet	Linear drive type 50ST20 NEWAVE *	page 8
Length not exceeding 80 feet	Linear drive type 63ST28 DEBP NEWAVE *	page 9

(* Data given as an indication only)

HYDRAULIC POWER PACKS AND LINEAR DRIVES FOR AUTOPILOTS

DIFFERENT TYPES OF INSTALLATIONS

Reversible Power Pack Single steering station + Power pack

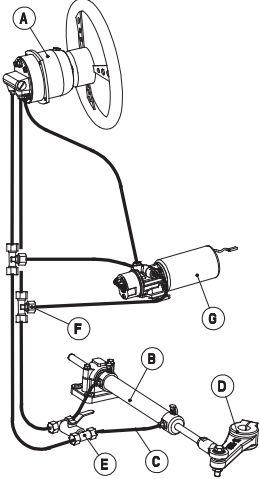

- A - 1 Pump + LV + fittings
- B - 1 Cylinder
- C - 2 Hoses + fittings
- F - Tees + connection fittings
- G - 1 Power pack

- Option D - Tiller arm
- E - By-pass valve

Reversible Power Pack Double steering station + Power pack

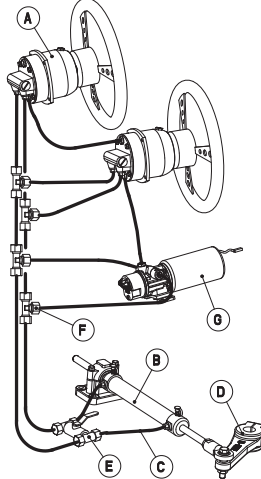

- A - 2 Pumps + LV + fittings
- B - 1 Cylinder
- C - 2 Hoses + fittings
- F - Tees + connection fittings
- G - 1 Power pack

- Option D - Tiller arm
- E - By-pass valve

Power packs with electrovalves Single steering station Double steering station

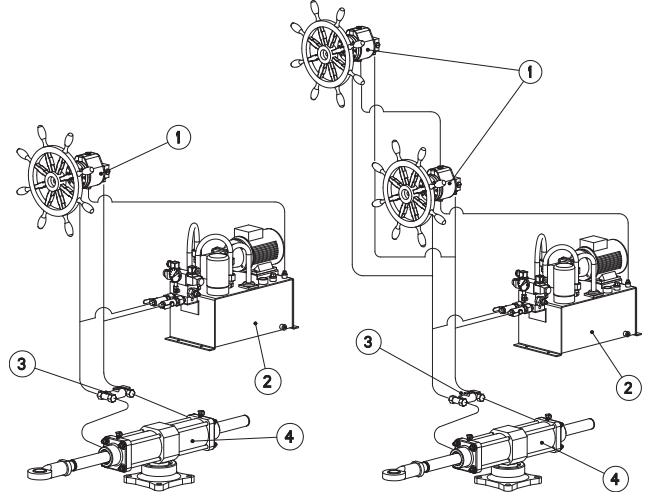

- 1 - Pump + LV
- 2 - Power pack
- 3 - By-pass valve
- 4 - Cylinder

POWER ASSIST STEERING

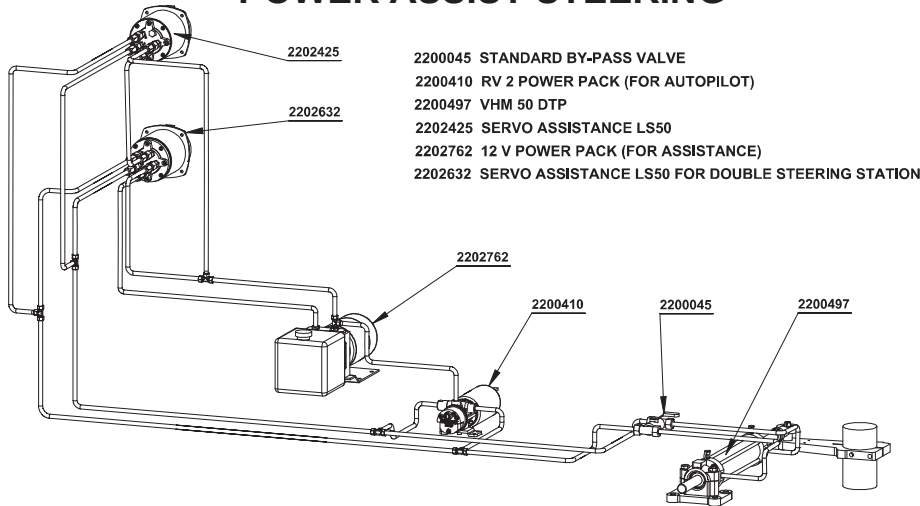

- 220045 STANDARD BY-PASS VALVE
- 2200410 RV 2 POWER PACK (FOR AUTOPILOT)
- 2200497 VHM 50 DTP
- 2202425 SERVO ASSISTANCE LS50
- 2202762 12 V POWER PACK (FOR ASSISTANCE)
- 2202632 SERVO ASSISTANCE LS50 FOR DOUBLE STEERING STATION

SAILING BOATS WITH QUADRANT

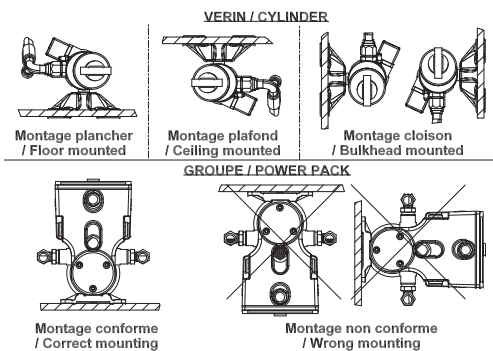
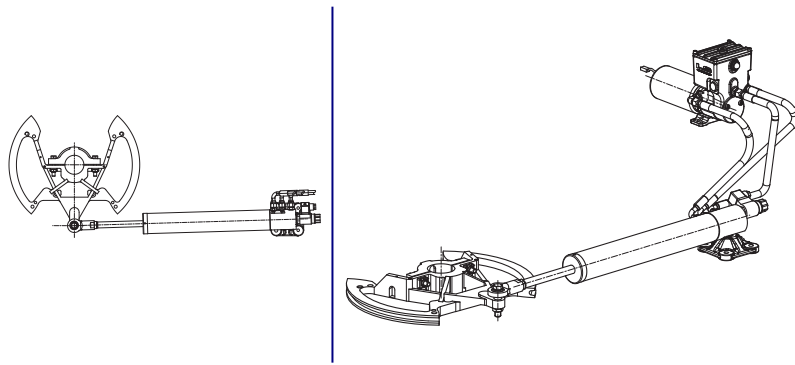

POWER PACKS FOR MOTORBOATS OR SAILING BOATS EQUIPPED WITH HYDRAULIC STEERING

REVERSIBLE POWER PACKS FOR DOUBLE ROD CYLINDERS

Hydraulic power packs with adjustable flow in 12 or 24 V for pleasure, fishing and work boats. They are reversible by changing the polarity on the motor terminals. Flow adjustment is done through a screw which allows accurate regulation of the time required for lock to lock displacement. These power packs are fitted with lock valves.

	12 VOLTS	24 VOLTS
RV 1	2200843	2200944
RV 2	2200410	2200945
RV 3	2200403	2200946

REVERSIBLE POWER PACKS FOR SINGLE ROD CYLINDERS

Hydraulic power packs with adjustable flow in 12 or 24 V for pleasure, fishing and work boats fitted with a single rod cylinder (unbalanced cylinder on outboard or stern-drive motors). They are reversible by changing the polarity on the motor terminals. Flow adjustment is done through a screw which allows accurate regulation of the time required for lock to lock displacement. These power packs are fitted with lock valves.

	12 VOLTS	24 VOLTS
RV 2-Z	2203240	2203261



Type of power pack	RV 1	RV 2 / RV 2-Z	RV 3
Maximum cylinder capacity (cc)	216	432	650
Power pack flow rate (l/mn)	0,1 à 1	0,2 à 2	0,3 à 3
Recommended protection 12/24 V	16 A / 6 A	25 A / 16 A	30 A / 16 A

30 bars maxi pressure – other pressures, contact us.

	A	B	C	D	E	F	G
RV 1 RV 2 / RV 2-Z RV 3	80 (3 5/32)	98 (3 7/8)	300 (11 13/16)	24 (15/16)	39 (1 35/64)	70 (2 3/4)	4

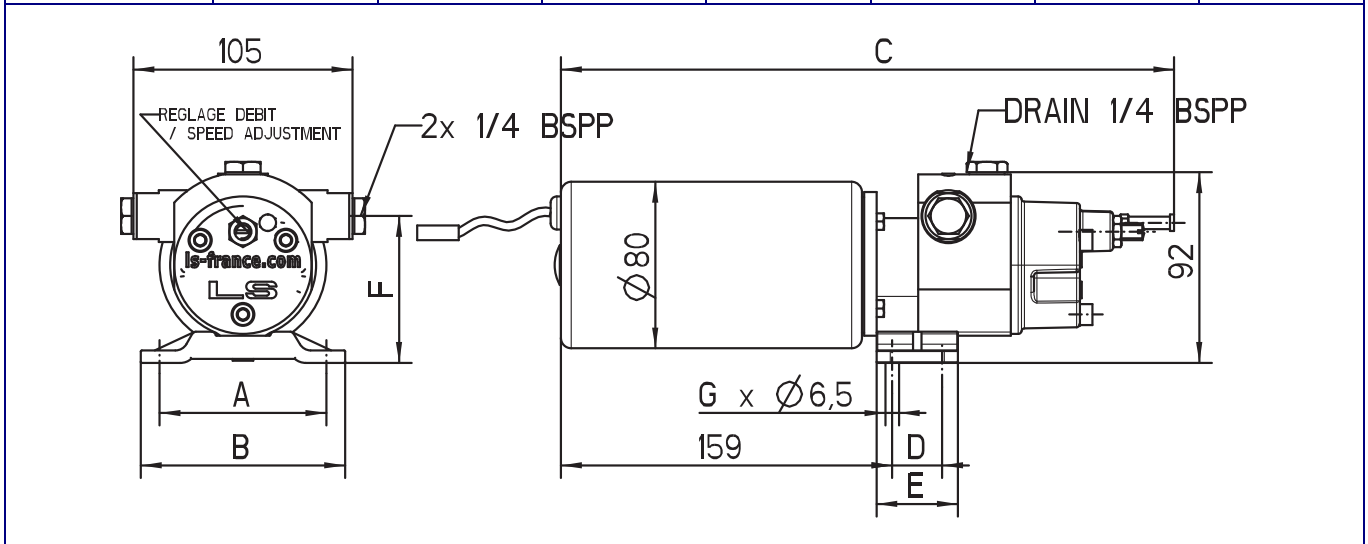

POWER PACKS FOR MOTORBOATS OR SAILING BOATS EQUIPPED WITH HYDRAULIC STEERING

POWER PACKS WITH ELECTROVALVES

Hydraulic power packs with adjustable flow in 12 or 24 V for pleasure, fishing and work boats. They are fitted with an electro-distributor and an oil reservoir. Flow adjustment is done through a screw which allows accurate regulation of the time required for lock to lock displacement.

Type of power pack	EV2	EV3
Maximum cylinder capacity (cc)	432	650
Power pack flow rate (l/mn)	0.2 à 2	0.3 à 3
Oil reservoir capacity	1 L	1 L
Recommended protection 12/24 V	25 A / 16 A	30 A / 16 A

▲ The pressure limiter has been factory adjusted (30 bars max. pressure). Please do not modify.

	12 V	24 V	A	B	C	D	E	F	G
E V 2	2200409	2200980	80 (3 5/32)	98 (3 7/8)	305 (11 1/64)	24 (15/16)	39 (1 35/64)	4	220 (8 11/16)
E V 3	2200844	2200981							

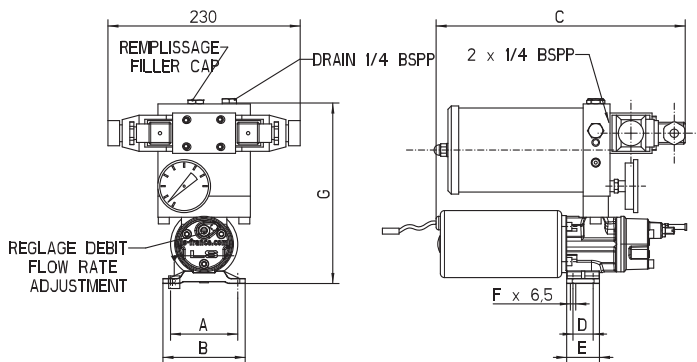

HF 1-2.5 – HF 1-3 – HF 1-4 HF 1-6 – HF 1.9-9 – HF 1.9-11 HF 3-15 – HF 3-18

Hydraulic H.F. units are mainly designed for large pleasure boats, fishing and work crafts.

Owing to a very strong construction, large oil tanks, high reliability of the pumps and distributors and to the easily accessible external mounting of elements connected with flexible tubes, these devices are the leaders on the market in the field of hydraulic electro-pump units.

Type code	Tank volume	Flowrate weight	A	B	C	D
HF 1-2.5 2200190	10 litres 2.65 US.gall	2.5 l/mn 35 kg	750 29 17/32	460 18 7/64	220 8 5/8	125 4 59/64
HF 1-3 2200148	10 litres 2.65 US.gall	3 l/mn 35 kg	750 29 17/32	460 18 7/64	220 8 5/8	125 4 59/64
HF 1-4 2200149	10 litres 2.65 US.gall	4 l/mn 35 kg	750 29 17/32	460 18 7/64	220 8 5/8	125 4 59/64
HF 1-6 2200150	25 litres 6.62 US.gall	6 l/mn 45 kg	750 29 17/32	560 22 3/64	270 10 5/8	225 8 7/8
HF 1.9-9 2200151	25 litres 6.62 US.gall	9 l/mn 57 kg	750 29 17/32	560 22 3/64	270 10 5/8	225 8 7/8
HF 1.9-11 2200195	25 litres 6.62 US.gall	11 l/mn 57 kg	770 30 5/16	560 22 3/64	270 10 5/8	225 8 7/8
HF 3-15 2200955	50 litres 13.2 US.gall	15 l/mn 61 kg	810 31 57/64	785 30 29/32	270 10 5/8	450 17 3/8
HF 3-18 2200562	50 litres 13.2 US.gall	18 l/mn 62 kg	810 31 57/64	785 30 29/32	270 10 5/8	450 17 3/8

60 bars maximum pressure.

Nota : Standard 24 VDC. Other voltages upon request

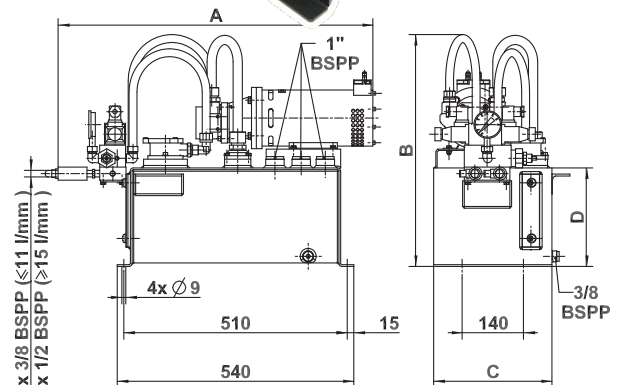

HYDRAULIC LINEAR DRIVES FOR SAILING BOATS EQUIPPED WITH MECHANICAL STEERING

INTERNAL INSTALLATION WITH FIXED FLOW



- Single rod hydraulic cylinder with integrated electrical by-pass.
- Compact overall dimensions.
- Directly fitted on the quadrant.
- **Possible floor, ceiling or bulkhead installation of the cylinder.**
- Separate reversible power pack with fixed flow for installation at your selected location.
- The kit is supplied assembled and bled with 1.20 metre flexible tube (Other lengths on request).
- Features the best thrust/electrical consumption ratio on the market.

COMPLETE KITS

2203063	Linear drive 32ST16 NEWAVE 12V RI
2203064	Linear drive 32ST16 NEWAVE 24V RI
▲ 2203066	Linear drive 40ST16 NEWAVE 12V RI
▲ 2203067	Linear drive 40ST16 NEWAVE 24V RI
2203068	Linear drive 50ST20 NEWAVE 12V RI
2203069	Linear drive 50ST20 NEWAVE 24V RI
2203070	Linear drive 50ST203 NEWAVE 12V RI
2203071	Linear drive 50ST203 NEWAVE 24V RI

▲ For steering wheel diameters exceeding 1200 mm we recommend that linear drives with adjustable flow on the reversible power packs be used (see page 10).

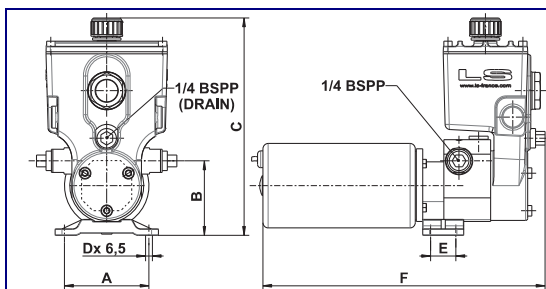

2203074 RV1 NEWAVE 12V	2203075 RV1 NEWAVE 24V
2203077 RV2 NEWAVE 12V	2203078 RV2 NEWAVE 24V
2203080 RV3 NEWAVE 12V	2203081 RV3 NEWAVE 24V

A	B	C	D	E	F
80	70	206	4	24	280
3 5/32	2 3/4	7 7/64		15/16	11 1/64

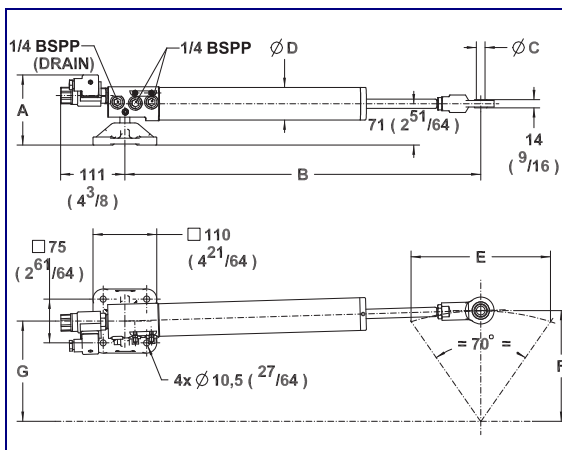

TYPE	VHM 32ST16 NEWAVE	VHM 40ST16 NEWAVE	VHM 50ST20 NEWAVE
Code 12V	2203084	2203086	2203088
Code 24V	2203085	2203087	2203089
Maximum thrust	280 kg 617 lbs	450 kg 992 lbs	700 kg 1543 lbs
Weight	3,5 kg 7.71 lbs	3,6 kg 7.9 lbs	5 kg 11 lbs
A	120 mm 4 23/32	120 mm 4 23/32	120 mm 4 23/32
B	563 mm 22 11/64	613 mm 24 1/8	715 mm 28 9/64
C	15 mm 19/32	15 mm 19/32	17 mm 43/64
D	46 mm 1 13/16	56 mm 2 55/64	70 mm 2 3/4
E	210 mm 8 17/64	240 mm 9 7/16	300 mm 11 13/16
F	170 mm 6 11/16	190 mm 7 31/64	240 mm 9 29/64
G	160 mm 6 19/64	172 mm 6 61/64	218 mm 8 37/64

HYDRAULIC LINEAR DRIVES FOR SAILING BOATS EQUIPPED WITH MECHANICAL STEERING

INTERNAL INSTALLATION WITH FIXED FLOW



- Single rod hydraulic cylinder with integrated electrical by-pass.
- Compact overall dimensions.
- Directly fitted on the quadrant.
- **Possible floor, ceiling or bulkhead installation of the cylinder.**
- Separate reversible power pack with fixed flow for installation at your selected location.
- The kit is supplied assembled and bled with 1.20 metre flexible tube (Other lengths on request).
- Features the best thrust/electrical consumption ratio on the market.

COMPLETE KITS

2203805

Linear drive 63ST28 DEBP NEWAVE 12V RI

2203802

Linear drive 63ST28 DEBP NEWAVE 24V RI

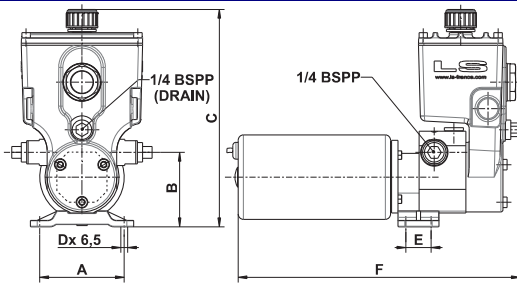

2203808 RV3 NEWAVE 12V

2203801 RV3 NEWAVE 24V

A

B

C

D

E

F

80

70

206

4

24

280

3 5/32

2 3/4

8 7/64

4

15/16

11 1/64

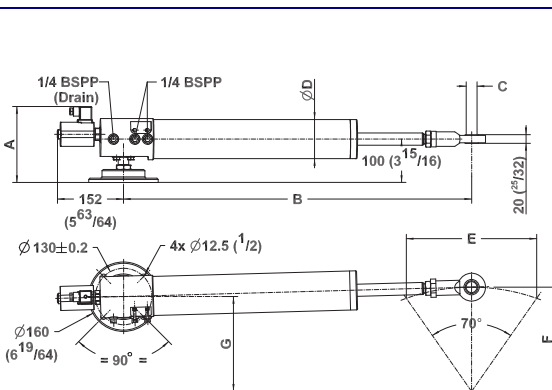

TYPE

VHM 63ST28 DEBP NEWAVE

Code 12V

2203806

Code 24V

2203803

Maximum thrust

1110 kg

2447 lbs

Weight

18 kg

39.65 lbs

A

180 mm

7 3/32

B

802 mm

31 37/64

C

25 mm

1 63/64

D

90 mm

3 5/64

E

300 mm

11 13/16

F

240 mm

9 29/64

G

218 mm

8 37/64

HYDRAULIC LINEAR DRIVES FOR SAILING BOATS EQUIPPED WITH MECHANICAL STEERING

INTERNAL INSTALLATION WITH ADJUSTABLE FLOW



- Single rod hydraulic cylinder with integrated electrical by-pass.
- Compact overall dimensions for installation on virtually all types of boats.
- Directly fitted on the quadrant.
- **Speed adjustment on the reversible power pack.**
- Separate reversible power pack with adjustable flow for installation at your selected location.
- The kit is supplied assembled and bled with 1.20 metre flexible tube*.
- All fittings in stainless steel.

COMPLETE KITS

2203603

Linear Drive 40ST16 REG DE BP 12V RI

2203616

Linear Drive 40ST16 REG DE BP 24V RI

* Other lengths on request.

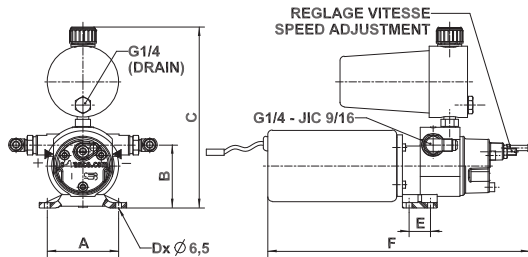

2201100 RV2 - ST - 12V

2201101 RV2 - ST - 24V

	A	B	C	D	E	F
RV2 - ST	80 3 ⁵ / ₃₂	70 2 ³ / ₄	206 7 ⁷ / ₆₄	4	24 - ¹⁵ / ₁₆	280 11 ¹ / ₆₄

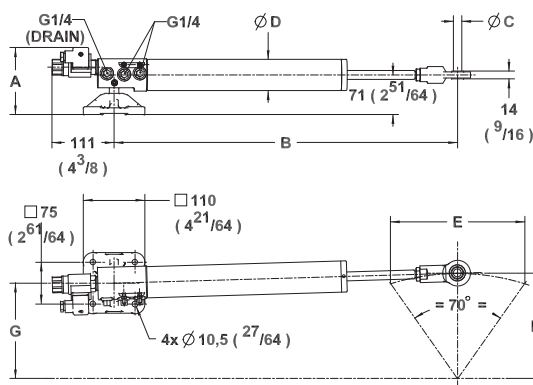

TYPE

VHM 40ST16 NEWAVE

Code 12V

2203086

Code 24V

2203087

Maximum thrust

450 kg

992 lbs

Weight

3,6 kg

7.9 lbs

A

120 mm

4 ²³/₃₂

B

613 mm

24 ¹/₈

C

15 mm

- ¹⁹/₃₂

D

56 mm

2 ⁵⁵/₆₄

E

240 mm

9 ⁷/₁₆

F

190 mm

7 ³¹/₆₄

G

172 mm

6 ⁶¹/₆₄

HYDRAULIC LINEAR DRIVES FOR SAILING BOATS EQUIPPED WITH MECHANICAL STEERING

EXTERNAL INSTALLATION (CYLINDER ONLY) WITH FIXED FLOW



- Single rod hydraulic cylinder with stainless steel fittings.
- Compact overall dimensions for installation on most types of boats.
- Directly connectable to the quadrant or the tiller arm.
- Separate reversible power pack with integrated electrical by-pass, for installation at your selected location inside the boat.
- The kit is supplied assembled and bled with 1.50 metre flexible tube*.

COMPLETE KITS

2203065	Linear drive 32ST16BP NEWAVE 12V
2203073	Linear drive 40T254BP NEWAVE 12V Elbow fittings on cylinder
2203937	Linear drive 32ST16BP NEWAVE 12V RI
2203938	Linear drive 40T254BP NEWAVE 12V RI Elbow fittings on cylinder

* Other lengths on request.

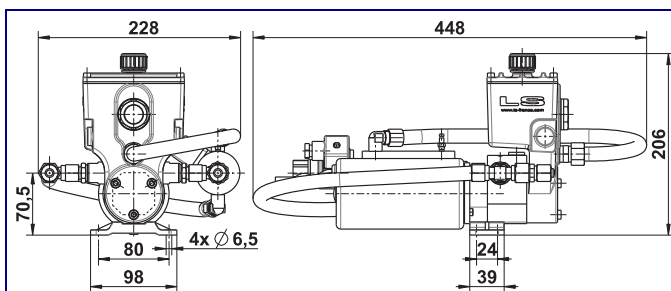

2203076	Power pack RV1BP NEWAVE 12 V
2203079	Power pack RV2BP NEWAVE 12 V

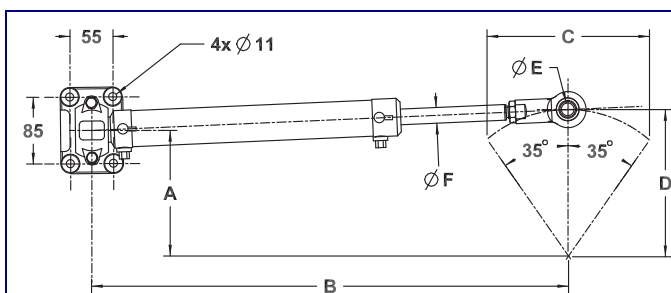

2201261	Cylinder VHM 32 ST 16 C172
2201960	Cylinder VHM 40 T C254

CODE	TYPE	A	B	C	D	E	F	Thrust
2201261	VHM 32 ST 16 C172	136.5	482	172	150	15	16	280 kg
2201960	VHM 40 T C254	200	609	254	220	17	20	450 kg

LINEAR DRIVES ACCESSORIES

OIL

2200017
2 Litre Oil Can
Dexron II



QUICK COUPLINGS

1205099 Ø 10 Quick Coupling in S/steel
2201557 Ø 15 Quick Coupling in S/steel
2201558 Ø 17 Quick Coupling in S/steel
2202486 Ø 20 Quick Coupling in S/steel



TILLER ARMS

Code	Designation	A	ØB
2202106	Pilot Bored Equipped Tiller Arm 32 ST 16 Ø 28 pilot bored – Maxi Ø 50	170	15
2201291	Pilot Bored Equipped Tiller Arm 40 ST 16 Ø 28 pilot bored – Maxi Ø 50	190	15
2201441	Pilot Bored Equipped Tiller Arm 50 ST 20 Ø 28 pilot bored – Maxi Ø 50	240	17

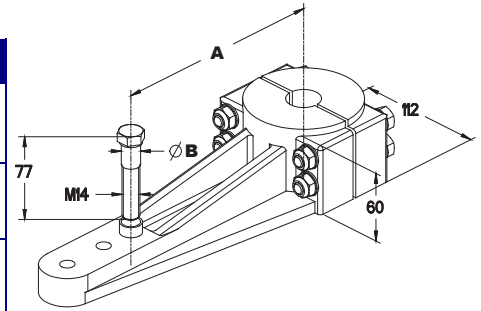

ENERGY SAVING DEVICE "ECOPILOT"

The "Ecopilot" energy saving device was designed to meet the demand for electrical energy saving on sailing-boats. Power reserve on board is often very limited, however it is essential for the operation of an autopilot system.

The "Ecopilot" acts on the electro-valve which engages the autopilot. The power consumption of this electro-valve represents a major part of the total autopilot consumption.

Its action consists of letting through - during a short moment – the necessary current for the electro-valve to switch on. Then the current is significantly reduced but still sufficient to maintain the electro-valve in position.

Thanks to this system, the daily consumption of the electro-valve is reduced in average from 30Ah to 5Ah.

2202047 ECOPILOT 12 V
2202048 ECOPILOT 24 V

Power supply12 or 24VDC, 30VDC max
Own Consumption0.01A
Output current at switching (I_e).....2.2A max
Output current after switchingaround $I_e / 6.5$
Switching time.....0.2s
Protection.....IP65
Power supply indicator.....LED yellow
Working temperature-20°C to +70°C

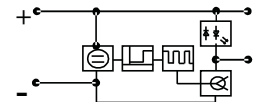





MAINTENANCE KITS FOR LINEAR DRIVES

2202457 Maintenance kit for linear drives standard and Newave **32ST16 / 40ST16 – 12 V**
2202459 Maintenance kit for linear drives standard and Newave **32ST16 / 40ST16 – 24 V**

2202458 Maintenance kit for linear drives standard and Newave **40T254 / 50ST20 – 12 V**
2202460 Maintenance kit for linear drives standard and Newave **40T254 / 50ST20 – 24 V**



Simple, handy, compact (Weight = 950 g)

Maintenance kit composition	Code
 Electro-hydraulic clutch 12 V	1202453
 Electro-hydraulic clutch 24 V	1202454
 Swivel yoke Ø 15	1200387
 Swivel yoke Ø 17	1200436
 Brush holder + Brushes All types RV1 – RV2	1200904

HYDRAULIC FLEXIBLE TUBES

FLEXIBLE TUBES FOR CRIMP CONNECTIONS

Only the sole use of LS flexible tubes in Ø6, Ø8 or Ø10 mm will guarantee the global performances of LS steering systems.

	Ø6	Ø8	Ø10
Per metre	2200810	2200024	2200070
8 meters	1204267	1204986	
10 meters	1204268	1204825	
12 meters	1204740	1204742	
13 meters		1204743	
15 meters		1202887	
16 meters		1204741	
20 meters		1205245	
25 meters	1204985	1207117	
35 meters	1205301	1205300	
50 meters	1207223	1207145	
100 meters	1207229	1207230	1207231
400 meters	1205359	1205360	
400 meters (on reel)	1207024	1207025	



FLEXIBLE TUBES WITH PRE-CRIMPED CONNECTIONS

High pressure flexible tubes of various lengths with pre-crimped connections of various kinds (several diameters, straight fittings, 90° elbow fittings). Stainless steel fittings available.

A few references in 10 L :

- Flex. tube R1T8 lg 500 – 2 x EFT10L **1290013**
- Flex. tube R1T8 lg 1000 – 2 x EFT10L **1290023**
- Flex. tube R1T8 lg 1500 – 2 x EFT10L **1290025**
- Flex. tube R1T8 lg 2000 – 2 x EFT10L **1290027**
- Flex. tube R1T8 lg 3000 – 2 x EFT10L **1290117**

A few references in 12 L :

- Flex. tube R1T10 lg 500 – 2 x EFT12L **1290042**
- Flex. tube R1T10 lg 1000 – 2 x EFT12L **1290052**
- Flex. tube R1T10 lg 1500 – 2 x EFT12L **1290054**
- Flex. tube R1T10 lg 2000 – 2 x EFT12L **1290056**
- Flexi. tube R1T10 lg 3000 – 2 x EFT12L **1290130**

A few references in 15 L :

- Flex. tube R1T13 lg 500 – 2 x EFT15L **1290385**
- Flex. tube R1T13 lg 1000 – 2 x EFT15L **1290376**
- Flex. tube R1T13 lg 2000 – 2 x EFT15L **1290387**
- Flex. tube R1T13 lg 2500 – 2 x EFT15L **1290378**

A few references in 18 L :





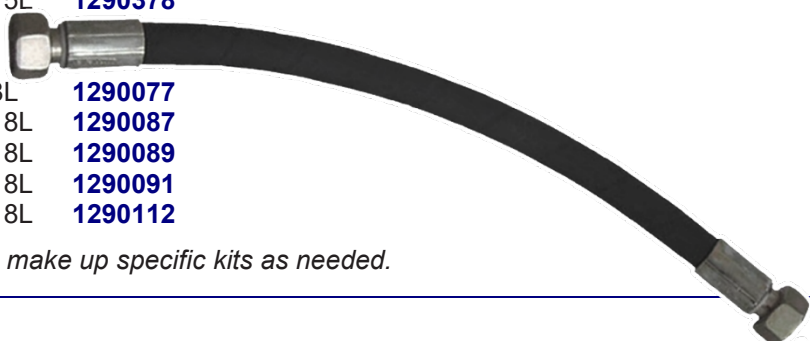







- Flex. tube R1T16 lg 500 – 2 x EFT18L **1290077**
- Flex. tube R1T16 lg 1000 – 2 x EFT18L **1290087**
- Flex. tube R1T16 lg 1500 – 2 x EFT18L **1290089**
- Flex. tube R1T16 lg 2000 – 2 x EFT18L **1290091**
- Flex. tube R1T16 lg 3000 – 2 x EFT18L **1290112**

Other lengths on request. Possibility to make up specific kits as needed.





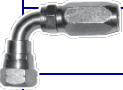



FITTINGS

FOR FLEXIBLE TUBE

Type	Designation	Code for steel	Code for s/steel
 Elbow fittings 90°	1/4 BSPT JIC M. 9/16	2200321	2200309
	3/8 BSPT JIC M. 9/16	2200426	
 Swivel elbow fitt.	1/4 BSPP JIC M. 9/16	1205997	1206365
 Swivel elbow fitt.	JIC M. 9/16 – JIC F 9/16	1205894	1205656
 Straight fittings	1/4 BSPT JIC M. 9/16	2200427	2200447
	1/4 BSPP JIC M. 9/16	2200199	2200448
	3/8 BSPT JIC M. 9/16	2200428	
	3/8 BSPP JIC M. 9/16	2200429	2202039
 Adapters	1/4 BSPT JIC F.T. 9/16	2200430	
	3/8 BSPT JIC F.T. 9/16	2200356	
 Connection fitt.	JIC M. 9/16	2200288	1206540
 Tee fittings	Rotatable 1/4 BSPP 2 x JIC M. 9/16	2200431	
	3/8 BSPT 2 x JIC M. 9/16	2200432	
 Equal tee fittings	JIC M. 9/16	2200433	2202009
 Swivel tee fittings	Rotatable JIC M. 9/16	2201566	
 Straight fittings	JIC M. 9/16 inner diam. 8	2200299	2200449
	JIC M. 9/16 inner diam. 10	2200301	
 Elbow fittings	Inner diam. 8	2200302	
	Inner diam. 10	2200303	
 Connection fitt.	Inner diam. 8	2200373	
	Inner diam. 10	2200434	

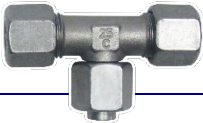
FOR INFLEXIBLE TUBE

 Straight fittings	1/4 BSPP diam. 8	2200435	
	1/4 BSPP diam. 10	2200436	1202695
	3/8 BSPP diam. 10	2200437	
	3/8 BSPP diam. 12	2200438	
	3/8 BSPP diam. 15	1203905	1205517
	1/2 BSPP diam. 18	2200439	2200866
 Elbow fittings	1/4 BSPT diam. 10	2200440	
	3/8 BSPT diam. 12	2200306	
	3/8 BSPT diam. 15	1204618	
	1/2 BSPT diam. 18	2200441	
 Tee fittings	1/4 BSPT diam. 10	2200442	
	3/8 BSPT diam. 12	2200443	1206034
	1/2 BSPT diam. 18	2200339	1205104
 Connection fitt.	Diam. 10	2200469	
	Diam. 12	2200585	
	Diam. 15	1206228	1205518
	Diam. 18	2200270	1204035
 Equal tee fittings	Diam. 8	2200444	
	Diam. 10	2200259	
	Diam. 12	2200445	
	Diam. 15	1204627	1206521
	Diam. 18	2200446	1205131
 Swivel tee fittings	Diam. 10	1204516	
	Diam. 12	1202634	
	Diam. 18	1202635	
 Reductions	1/8 BSPP M – 1/4 BSPP F	1202438	
	1/4 BSPP M – 3/8 BSPP F	2200390	1206522
	1/4 BSPP M – 1/2 BSPP F	2200389	2200859
	3/8 BSPP M – 1/4 BSPP F	2200374	1203268
	3/8 BSPP M – 1/2 BSPP F	2200396	2200858
	1/2 BSPP M – 1/4 BSPP F	2200221	1202696
	1/2 BSPP M – 3/8 BSPP F	2200332	1206528

CONNECTION KITS FOR RAYMARINE, SIMRAD AND GARMIN AUTOPILOTS WITH LS OUTBOARD STEERING SYSTEMS

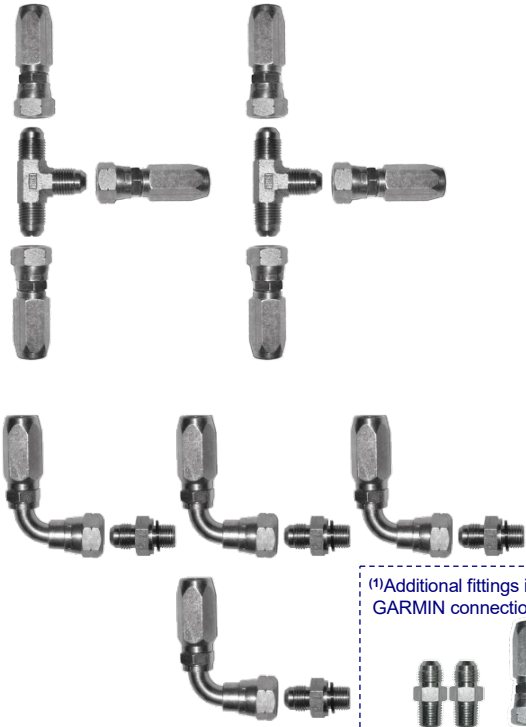
Kit of fittings collars + pipettes Ø6 and Ø8 mm		Kit of reusable fittings Ø8 mm	
			
Designation	Code	Designation	Code
RAYMARINE / SIMRAD Connection kit S1000 - Ø6	2202481	RAYMARINE / SIMRAD Connection kit S1000 - Ø8 REC	2202483
RAYMARINE / SIMRAD Connection kit S1000 - Ø8	2202482	GARMIN Connection kit (after 02/2018) - Ø8 REC ⁽¹⁾	2203832

⁽¹⁾Additional fittings included in the GARMIN connection kit 2203832



LS Outboard Steering	Ø 6 Flex. Tube for crimping (collar)	Ø 8 Flex. Tube for crimping (collar)	Ø 8 Flex. Tube reusable fittings		
	RAYMARINE / SIMRAD Connection kit	RAYMARINE / SIMRAD Connection kit	RAYMARINE / SIMRAD Connection kit	GARMIN Connection kit	
LS 2024	2202481*				
LS 226	2202481*				
LS 2428	2202481*				
LS 75 PRO / 80 PRO	2202481*				
LS 125 PRO / 150 PRO	2202481*				
LS 228			2202483	2203832	
LS 2832 / 200 PRO		2202482*	2202483	2203832	
LS 175 PRO / 225 PRO		2202482*	2202483	2203832	
LS 232			2202483	2203832	
LS 350 PRO / 3500 PRO			2202483	2203832	Each kit is supplied with 8 m flexible tube

* For double steering station, add to the standard kit:

	Designation	Code
	Tee fitting for flex. tube Ø 6	2202498
	Tee fitting for flex. tube Ø 8	2202499

NOTES

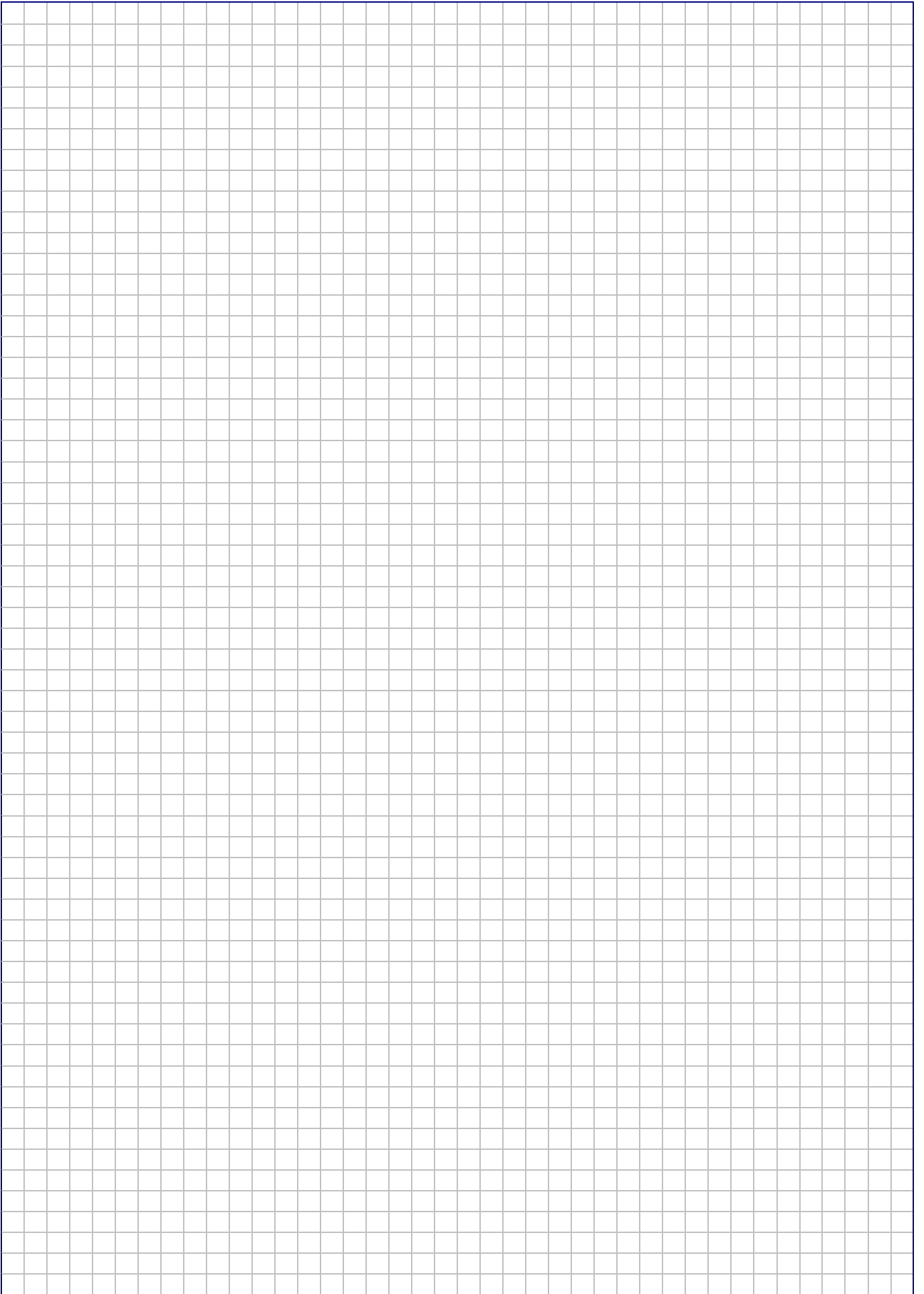

GUARANTEE

- 1) The manufacturer guarantees the equipment sold and supplied against any faulty manufacturing or defects whether they are the result of the design, the raw material, the manufacturing or construction under the terms and restrictions indicated below :
 - 2) The guarantee is applicable only if the client has satisfied the general obligations of this contract, in particular, the terms of payment.
 - 3) The guarantee only includes equipment sold by the manufacturer. It does not extend to equipment in which the manufacturers supply has been installed and, in particular, to the performances of this equipment.
 - 4) When the manufacturers supplies are installed by the client or a third party into any other equipment, they remain solely responsible for this installation, the selection and suitability of the manufacturers supplies as the manufacturers diagrams, designs and proposals are given as an indication only, unless otherwise specified in the order. In particular, the manufacturer does not guarantee components or equipment not sold by him, nor the assembly, adaptation, design or operation of the assembly or parts of the assembly thus created. The manufacturers supply, as well as the assembly created by the client or a third party, are assumed to be operated under the exclusive control of the client or the third party.
 - 5) The period of the guarantee is eighteen months starting from the date of first use by the original consumer or twenty four months from the date of delivery of the products to the transporter, distributor or wholesaler. The manufacturer has the right to require from the client proof of the commissioning date specified on the guarantee request. This period is neither extended nor interrupted through legal or amicable claims on the part of the client. At the end of this period, the guarantee is terminated without further consideration.
 - 6) The obligation of the guarantee only applies if the client establishes that the defect appeared under normal operating conditions stipulated for this type of supply, or indicated by the manufacturer in writing and during normal operation. It does not apply in case of negligence, faulty maintenance or supervision, operators responsibility, imprudence, non observance of recommended or operating instructions, or the use of oil of insufficient quality for the equipment. The manufacturer is released from responsibility for any damage caused by loss of oil or leaks. The guarantee also does not apply for any incidents resulting from a case of force majeure or Acts of God, as well as any damage, replacement or repairs exceeding the normal material wear.
 - 7) The guarantee is limited to the repair in the manufacturer's shop at his own cost within the shortest possible time, of the equipment and parts supplied by him, identified as defective by the technical department. These parts must be sent pre-paid. No claim may be made for compensation for any damage such as personal injury, damage to goods other than those concerned in this contract, privation of possession, operating losses, commercial damage or loss of earnings. During the guarantee period, the cost of labor, dismantling and reassembly of the equipment outside the manufacturer's plant, the shipping costs for repaired, replaced or faulty equipment, travelling and accommodation expenses for technicians are the responsibility of the client.
- When the guarantees are given according to the industrial results for a given equipment, these results and the consequences of this undertaking will result in a special agreement between the parties.
- 8) In order to take advantage of this guarantee, the client must notify the manufacturer in writing as soon as possible of the defects attributed to the equipment and provide any proof concerning these defects. He must do his best for the manufacturer to be able to ascertain these defects and to perform corrective actions. The guarantee does not apply if the equipment is not returned to the manufacturer in the state in which it broke down or if it has previously been disassembled, repaired, modified either by a third party, the user or the client. After receiving proper notification of the equipment defect, the manufacturer shall correct this fault as soon as possible, reserving the right, if applicable, to modify all or part of equipment in order to fulfil the obligations.
 - 9) The client agrees that the manufacturer will not be responsible for damage due to the fact that the client has not satisfied anyone of the obligations defined above.

Sales Department

☎ +33 (0)559 562 411
commercial@ls-france.com

Technical Department

☎ +33 (0)559 562 646
commercial2@ls-france.com



Sailing is an art... Accompanying you is our business!

LECOMBLE & SCHMITT - 156 Route de Briscous - 64240 Urt

☎ +33 (0)559 562 222 - commercial@ls-france.com



Distributed by

