

User Documentation

Applicable for:

Typenumber	Category	Family
HD 15T27 MMD-yyy-Fyyyyy	Monitor	HATTELAND® Series X G3
Product Status	HWcode Description	
Active		LED

Document overview:

ID: INB102001-1

Compilation date: 26 June 2026 - Compiled manually by Website request.

**Note: Revision history is listed pr. chapter on the last pages of this compilation.
Last page (may) include Legacy revision history which is not maintained after January 2023.**

Documents included:

INB102001-1 - Frontpage
IND100106-7 - Rev 02 - 19 Dec 2025 - [General] - User Documentation statement
IND100131-67 - Rev 01 - 17 Jan 2025 - [General] - Contents of package
IND100078-81 - Rev 01 - 20 Jan 2023 - [General] - Safety introduction and overview
IND100110-12 - Rev 01 - 16 Oct 2024 - [General] - Touchscreen overview
IND100110-22 - Rev 03 - 10 Nov 2025 - [General] - Touch Screen drivers and calibration
IND100077-321 - Rev 01 - 10 Sep 2024 - [General] - Product labeling and locations
IND100077-322 - Rev 01 - 9 Sep 2025 - [General] - Product labeling details
IND100210-14 - Rev 01 - 20 Jan 2023 - [Installation] - Housing / terminal block connector overview
IND100078-123 - Rev 01 - 19 Aug 2025 - [Installation] - Installation recommendations
IND100078-45 - Rev 01 - 20 Jan 2023 - [Installation] - Panel Cutout / Console Mounting Bracket Kit for 15, 17 and 19 inch
IND100078-46 - Rev 01 - 20 Jan 2023 - [Installation] - Panel Cutout / Console Mounting Bracket Kit for 24 and 27 inch
IND100078-115 - Rev 01 - 12 Sep 2024 - [Installation] - Mounting Bracket, Table / Desktop / Ceiling - 15, 17 and 19 inch
IND100078-116 - Rev 01 - 24 Oct 2024 - [Installation] - Mounting Bracket, Table / Desktop / Ceiling - 24 and 27 inch
IND100133-101 - Rev 02 - 17 Oct 2025 - [Physical Connections] - Physical Connections MMD SeriesX-G3
IND100133-106 - Rev 01 - 19 Aug 2025 - [Physical Connections] - Physical connections (Expansion Board)
IND100064-40 - Rev 01 - 20 Jan 2023 - [User Controls] - User controls
IND100064-90 - Rev 01 - 19 May 2025 - [User Controls] - On Screen Display (OSD) Menu - Functions map
IND100064-91 - Rev 01 - 19 May 2025 - [User Controls] - On Screen Display (OSD) Menu - Functions
IND100084-17 - Rev 02 - 19 May 2025 - [Serial Communication Control Interface (SCOM)] - Serial Communication (SCOM) Interface - Introduction
IND100084-48 - Rev 02 - 21 Jan 2026 - [Serial Communication Control Interface (SCOM)] - Message commands and queries
IND100084-51 - Rev 01 - 14 Aug 2025 - [Serial Communication Control Interface (SCOM)] - MCC Commands List
IND100084-23 - Rev 01 - 20 Jan 2023 - [Serial Communication Control Interface (SCOM)] - Operational requirements
IND100077-259 - Rev 01 - 20 Jan 2023 - [Serial Communication Control Interface (SCOM)] - Calculating checksums (IDCHK, IHCHK)
IND100077-122 - Rev 01 - 20 Jan 2023 - [Serial Communication Control Interface (SCOM)] - HEX, ASCII, BIN and character tables
IND100077-124 - Rev 01 - 20 Jan 2023 - [Serial Communication Control Interface (SCOM)] - C# / pseudo ethernet/TCP code example
IND100064-52 - Rev 01 - 14 Aug 2025 - [Appendix] - Operation Advanced (DDC/C1) Control Overview
IND100078-80 - Rev 01 - 20 Jan 2023 - [Appendix] - IEC62368 policy
IND100077-185 - Rev 01 - 20 Jan 2023 - [Appendix] - Troubleshooting
IND105367-1 - Rev 02 - 16 Oct 2024 - [Appendix] - Parts and recycling
IND100077-171 - Rev 01 - 20 Jan 2023 - [Appendix] - General notes
IND105446-3 - Rev 01 - 17 Feb 2023 - [PinOut Assignment] - 2-pin Terminal Block 5.08 - DC Power Input
IND105446-79 - Rev 01 - 20 Feb 2023 - [PinOut Assignment] - Grounding Screw
IND105446-36 - Rev 01 - 22 Feb 2023 - [PinOut Assignment] - 9-pin Serial COM RS-232+Buzzer non-isolated, DSUB Male
IND105446-4 - Rev 01 - 17 Feb 2023 - [PinOut Assignment] - 20-pin DisplayPort (DP) Female
IND105446-16 - Rev 02 - 6 Sep 2024 - [PinOut Assignment] - PinoutAssignments 19pin HDMI2.0 Female
IND105446-32 - Rev 02 - 11 May 2023 - [PinOut Assignment] - 9-pin User User Interface/ON-OFF/Dimming, DSUB Male
IND105446-11 - Rev 02 - 3 Apr 2024 - [PinOut Assignment] - 10-pin RS-422 / RS-485 Module w/Buzzer
IND105446-1 - Rev 01 - 17 Feb 2023 - [PinOut Assignment] - 8-pin RJ45 10/100/1000Mbps LAN/Ethernet
IND105446-73 - Rev 01 - 20 Feb 2023 - [PinOut Assignment] - 4-pin USB2.0 TYPE A Female
IND105446-76 - Rev 01 - 15 Aug 2023 - [PinOut Assignment] - 24-pin USB-C TYPE A Female
INB102001-1 - Revision History
INB102001-1 - Legacy Revision History (if available)

Statement

HATTELAND TECHNOLOGY

an EMBRON Company 

Copyright © 2025 Hatteland Technology AS
Eikeskogvegen 52, N-5570 Aksdal, Norway.

All rights are reserved by Hatteland Technology AS. This information may not, in whole or in part, be copied, photocopied, reproduced, translated or reduced to any electronic medium or machine-readable form without the prior written consent of Hatteland Technology AS
Review 'Permission to Create User Manuals' document on our website, product page and its Downloads section.

The products described, or referenced, herein are copyrighted to the respective owners.
The products may not be copied or duplicated in any way. This documentation contains proprietary information that is not to be disclosed to persons outside the user's company without prior written consent of Hatteland Technology AS.

The copyright notice appearing above is included to provide statutory protection in the event of unauthorized or unintentional public disclosure.









All other product names or trademarks are properties of their respective owners !

WARNING: This is a class A product. In a domestic environment this product may cause radio interference in which case the user may be required to take adequate measures.

Statement above last revised 19 Dec. 2025

Contents of package

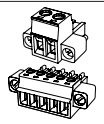
Note: Entries listed below are for Standard factory shipments. Customized factory shipments may deviate from this list.

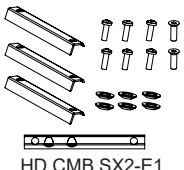
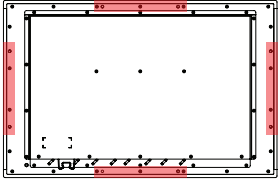
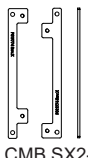
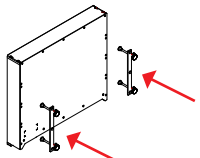
Item	Description	Illustration
 TP52/TC01-1,8M	1 x Power Cable (Black) European Type F "Schuko" to IEC. Length 1.8m	EUR TYPE F ↔ IEC 
 TP11/TC01-1,8M	1 x Power Cable (Black) US Type B plug to IEC. Length 1.8m	US TYPE B ↔ IEC 
 VSD101004-2	1 x DisplayPort male to male type. length 2.0m	
 Terminal Block Connector Kit	Terminal Block Connector Kit as follows (may in some cases be already factory mounted): 1 x 2-pin Terminal Block 5.08 for DC Power In 2 x 5-pin Terminal Block 3.81 for RS-422 / RS-485 / SCOM / Buzzer Module Refer to "Configuring Housing / Terminal Block Connector" section for usage.	 Note: Location of module(s) may differ between unit sizes
 HD CMB SX2-E1	Model Dependent: Bracket Kit suitable for console/panel mounting which contains: 3 x Mounting Bracket for top, left and right side (P006858-1) 1 x Mounting Bracket for bottom side (terminal/connector plate area) (P020605) 6 x M5x16 Pan Head screw ISO 14583 Torx, A4 screws (145 050x016 A4T) 6 x M6 C-washers DIN6319 Steel (144 064x120x22) 2 x DIN 965 M5x16 Countersunk head screws with TX25, A4 STAINLESS STEEL (145 050x016 CA4) Suitable only for 24 and 27 inch units and is EN60945 Tested.	
 HD CMB SX2-A1	Model Dependent: 2 pcs of Mounting Brackets for Console/Panel Mounting, Anodized Aluminium/Stainless Steel. The bracket kit is suitable for 15, 17 and 19 inch units and is EN60945 Tested (pending). Suitable for panel thickness min: 2.0 [0.08"] to max: 50.00 [1.97"] mm [inch].	

Package may also include:

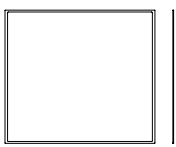
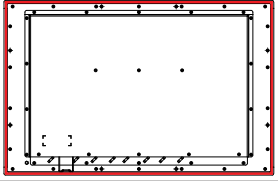



Item	Description	Illustration
VSD203765-1	1 x Touch Screen Cable (Black) USB Type A to Type C. Length Approx 2m. <i>Only included in package if model is equipped with factory mounted Touch Screen</i>	
	For models (15-27 inch) an EPDM sealing gasket for IP66 console mount may be factory pre-mounted / included with delivery if ordered. For High Bright models, it is pre-mounted by factory default. Details / Type number reference: Surface: RAL9011, Glue: 3M9471LE, Thickness 2mm. P006997-1 (15), P007130-1 (17), P007131-1 (19) P022211 (24), P018743 (27)	

IEC62368 policy - Introduction

Safety Instructions

Please read and understand the material in this manual in its entirety before doing any installation/servicing/upgrades. Personnel who are allowed to do work on the unit is detailed in the “**IEC62368 policy for Hatteland Technology product**” section later in this manual. Symbols pertaining to different personnel in regard to operations is described in the user manual.

Based on requirements EN 62368-1:2014 and IEC 62368-1:2018

Authority	Description
Children 	This equipment is not suitable for use in locations where children are likely to be present.
Ordinary person/ Sailor/End-User 	Not allowed to open unit. Not allowed to install the unit. Not allowed to terminate/connect cables to the unit.
Instructed person 	Allowed to open hatches/latches which does not require tools, such as Disktrays. Allowed to open "battery-hatch" to change the battery even if tools are required. Allowed to install the unit. Allowed to terminate/connect cables to the unit indoors.
Skilled person 	Allowed to open and disassemble the unit. Allowed to install the unit. Allowed to terminate/connect cables to the unit indoors and outdoors. Allowed to terminate/connect earth/ground wire. Note: Be aware that additional definition for “skilled person” may apply, country dependent.

Touch screen products

Introduction to products with touch screen (factory option)

Nearly all of our products with touch screen use Projected Capacitive Touch screen (PCTS), widely used with great success on mobile phones and typical pad devices. PCTS can be equally effective also for marine applications. One of the advantages of PCTS is that it has features seen in both resistive and surface capacitive touch screen technologies.

Multitouch is defined as the ability to recognize two or more simultaneous touch points. Using projected capacitive technology allows us to create a more intuitive form of human-device interaction. Touch interface gestures, supported by projected capacitive sensors, can simplify the interface and provide an intuitive user experience that goes beyond the typical "button replacement" found in most simple touch interfaces.

Please review the appropriate Product Datasheet (in this manual) to determine if PCTS are supported and/or its advanced features of additional touch methods (example Tactor and Active Stylus Pen) are available.

The technical benefits of PCTS are:

- Very good optical performance (same as surface capacitive)
- Environmentally strong, the touch sensor is inside the product (better than both surface capacitive and resistive)
- Supports Multitouch (Newer Operating System (OS) required in most cases.
- Excellent readability - light transmission of up to 91% through a standard sensor
- Stability - no drift, therefore no recalibration is required
- Pointing device - works with gloved and ungloved finger
- Resistance to contamination - by harsh cleaning fluids and other noxious substances
- Communicates via USB to external computer or internally

Comparisons between general Touch Technologies used by Hatteland Technology:

Technology	Optical Performance	Gloves	Water	Durability	Multitouch	Stylus	Objects (Tactor)
Analog Resistive	--	++	++	-	-	-	--
Surface Capacitive	++	--	-	+	-	-	--
Projected Capacitive	++	+	+*	++	++	++	++

*Projected Capacitive (PCTS) / Water: Touch Screen Glass Surface can withstand drip and direct rain, but expect reduced capability, detection and performance if units are exposed to these factors while powered. Hatteland Technology recommends protecting the unit from direct rain or drips if critical touch operations are to be performed. Take necessary steps (if detected or suspected) within the installation environment to prevent accidental touch gestures or presses not performed intentionally by a human operator.

Touch Screen Products

Touch Screen Drivers

All units with Touch Screens are automatically detected by the Operating System via HID. There is no need to install additional Third-Party touch screen drivers.

Microsoft® Windows® Svr Emb Std 2012 / Microsoft® Windows® 7 / Microsoft® Windows® 10 IoT / Microsoft® Windows® 11 IoT:

- Please use Windows® Generic HID driver, no specific driver needed to use multi-touch.
- Alternative configuration available: See “Mouse Mode feature” below.

Mouse Mode feature:

The Multi-Touch screen interface can be configured to support mouse emulation to support certain legacy software. If your system and its GUI (Graphical User Interface) experience lack of response to gadgets/buttons pressed via touch screen, the package below might help. This feature works from **Microsoft® Windows® XP** and up. Please note that Multi-touch will be disabled and replaced by Single Touch mode.

https://www.hattelandtechnology.com/support-archive-touch-screen-drivers?technology=&interface=&os=&os_version=&driver_id=111&product_id=
ref: <https://www.hattelandtechnology.com/product-notifications/new-touchscreen-solution-series-x-g2-mmd-15-17-19-inch>

Linux

- Please use Linux Generic Touch driver.
- Note: Kernel before 2.6.38: Single touch support.
- Note: Kernel above 2.6.38: Multi touch support.
- Note: For optimal graphical performance/hardware support with Skylake/Kaby Lake CPU's on T22 MMC units, the Linux Kernel 4.4 or later is required/recommended.

Note for Microsoft® Windows® XP Support:

- Multi-Touch Screen is not supported for this Operating System or Hatteland Technology products described in the manual supports Windows XP. End of Life reference:
<https://www.hattelandtechnology.com/product-notifications/update-eol-microsoft-windows-xp-professional-for-embedded-systems-and-microsoft-windows-xp-embedded>

Touch Screen Products

Touch Screen Calibration

If you experience any deviation in the touch input accuracy, consider re-calibrating the touch screen for your system. Procedures below are for standard Microsoft® Windows® Operating System calibrate functions.

Example for Microsoft® Windows® 10 IoT:

1. Open Control Panel.
2. Click on Hardware and Sound.
3. Under “Tablet PC Settings,” click the Calibrate the screen for pen or touch input link.
4. Under “Display options,” select the display (if applicable).
5. Click the Calibrate button.
6. Select the Touch input option.

Example for Microsoft® Windows® 7:





- 1: Open Control Panel.
- 2: Open “Tablet PC Settings”.
- 3: Under “Display options,” select your display.
- 4: Click the Calibrate button and follow instructions.
- 5: To save settings, click “Apply” or “OK” on the “Table PC Settings” window.

Product Labeling

Introduction

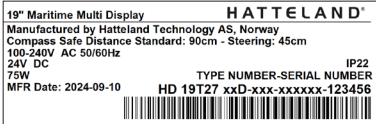
This section details the locations, content details and specifications for factory mounted labels for all currently available standard Hatteland Technology Maritime Multi Display (MMD) models. This information will in most cases also apply for most Customized Models as well, but may differ based on customer requirements, in that case, please refer to the customized User Manual (paper or electronic version, dependent on customer requirements).

Label Size and Types

ID	Label Layout	Description	Specification
1		Type : Serial Number Label Name : Label B Size : 60mm wide x 20mm high (rectangle size) Note: Text content of label will match specifications derived from Datasheet.	Silver with glue on back, non-tearable and made for thermal transfer printing.
	<p>Please note that typenumber shown above is a generic sample only. May not reflect products mentioned in this manual. Please review actual product S/N label.</p>	Barcode type: CODE128 (used extensively world wide in shipping and packaging industries. The symbology was formerly defined as ISO/IEC 15417:2007.)	
4		Type : Warranty Label Size : 30mm wide x 23mm high (oval size)	Tamper-proof sticker with glue on back.
9		Type : Product Label (Variant #1) Art : IND105459-5 Size : 60mm wide x 26mm high (rectangle size) Note : For products w/single power input	Black label, Lexan 0,125 3M467 Adhesive
9		Type : Product Label (Variant #2) Art : IND105459-6 Size : 60mm wide x 26mm high (rectangle size) Note : For products w/more than 1 power input	Black label, Lexan 0,125 3M467 Adhesive

Product Labeling

Label Locations

Number ID and coloring based on “Label Size and Types” table from previous page. All illustrations below are seen from rear (and side where needed) with connectors facing down. Actual labels regarding its size and text orientation vs product size is drawn in. Due to space restrictions on selected units, some labels will be rotated 90 degrees to fit properly. The arrangement of labels may be shifted/stacked differently as it is based on factory options, such as; Touch Screen, but they will be grouped together where possible.

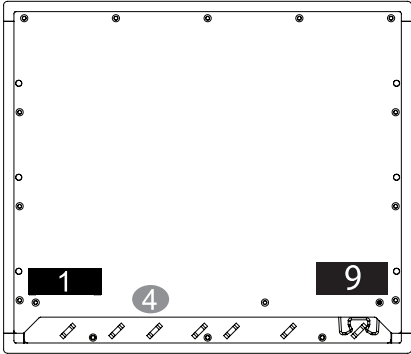
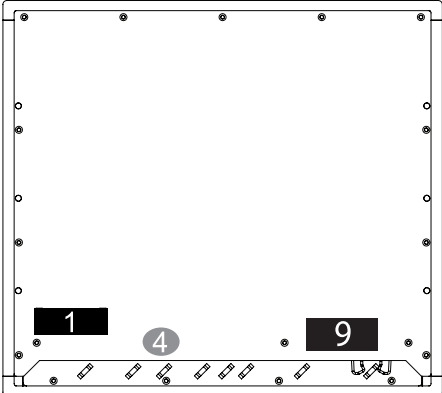
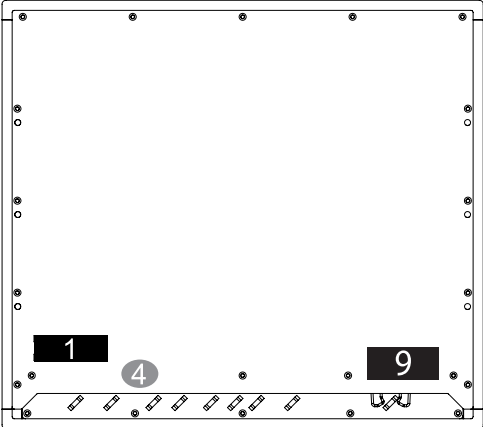
Label Positions	Notes	Applies for Product Range
	<p>Warranty label covers screw. Labels placed on rear.</p>	<p>HD 15T27 MMD-xxx-Fxxx</p>
	<p>Warranty label covers screw. Labels placed on rear.</p>	<p>HD 17T27 MMD-xxx-Fxxx</p>
	<p>Warranty label covers screw. Labels placed on rear.</p>	<p>HD 19T27 MMD-xxx-Fxxx</p>

Product Labeling

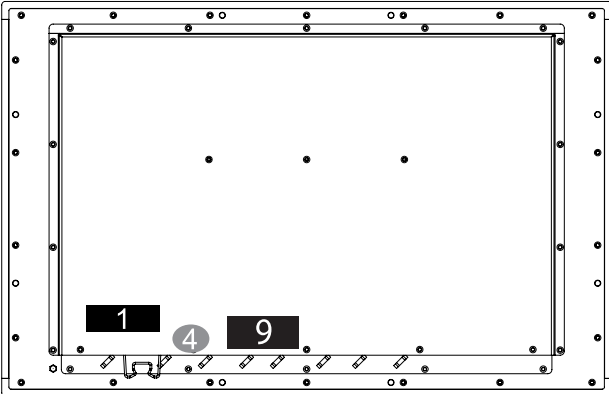
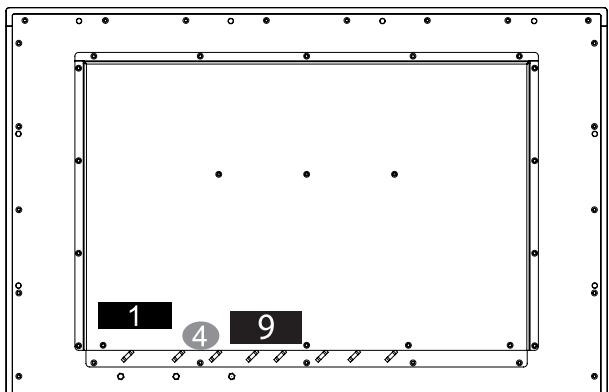
	<p>Warranty label covers screw. Labels placed on rear.</p>	<p>HD 24T27 MMD-xxx-Fxxx</p>
	<p>Warranty label covers screw. Labels placed on rear.</p>	<p>HD 27T27 MMD-xxx-Fxxx</p>

Product Labeling

Warranty Label

If you are to perform service on a unit still under warranty, any warranty will be void if this label shows signs of removal attempts or damaged by screw driver. This label is located on the back of the product and covers a key screw. This is to aid service departments in determining if there has been any unauthorized service on a unit still under warranty.

Quality Control (QC)

Indicates that the unit is produced, tested and packed according to the manufacturer's QA specifications.

Handling Symbol

Ecodesign Requirements for Electronic Displays. The European Union published the Regulation 2019/2021 with specific environmental ecodesign requirements for various types of electronic displays, such as TVs, monitors, and digital signage displays.

Serial Number Label Layout (example)

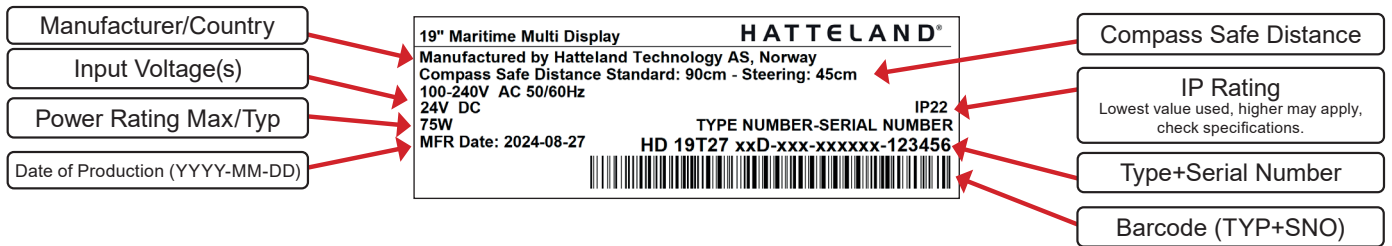

Please note that typenumber shown above is a generic sample only. May not reflect products mentioned in this manual. Please review actual product S/N label.

General Installation Recommendations

Housing / Terminal Block Connector Overview

Housing / Terminal Block connectors are available in different sizes (example 2-pin, 4-pin, 5-pin) which plug into the connector area of the unit. They are mounted by factory default and delivered with the unit. The housing / terminal block connectors have steering rails, which ensures that it can not be mounted wrong. The color of these connectors may vary between black, green and orange depending on manufacturer. You may use approved equivalents of these connectors, but note that the warranty will be void if any damage would occur to either the unit's original PCB terminal socket connector or inside the unit (electronic components, boards etc.). The table below is applicable for any Series X products, such as Display and Panel Computers, including newer type of Stand-Alone Computers.

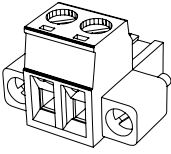
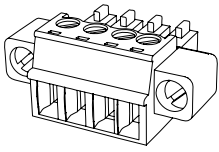
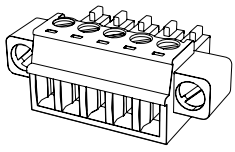
Illustration	Pins	Manufacturer Details	Connector used for module
	2-pin	MSTB 2,5/ 2-STF-5,08 BK Screwdriver: SZS 0,6x3,5, slot-headed. Tightening torque min. 0.5 Nm. Tightening torque max 0.6 Nm.	• DC Power IN (24VDC) - Dual Input Identified on Hatteland Technology product datasheet as: "Terminal Block 5.08"
	4-pin	BCZ 3.81/04/180F SN BK BX Screwdriver: 0.4x2.5mm DIN 5264. Tightening torque min.. 0.2 Nm. Tightening torque max. 0.25 Nm.	• CAN Interface (ZIA0001310-B / ZIA0001310-SLCAN) Identified on Hatteland Technology product datasheet as: "Terminal Block 3.81"
	5-pin	MC 1,5/ 5-STF-3,81 Screwdriver: SZS 0,4X2,5mm VDE, slot-headed. Tightening torque min. 0.22 Nm. Tightening torque max 0.25 Nm.	• RS-422 / RS-485 NMEA (PCA200828-1 / PCA100293-1 Q170 IO) • Digital Input/Output (PCA100297-1 / Q170 IO) Identified on Hatteland Technology product datasheet as: "Terminal Block 3.81"

If your installation requires additional cable fasteners support, please visit and purchase directly from manufacturer: Illustrations below are approximate, actual Housing and Hood may deviate slightly, but function remains the same.

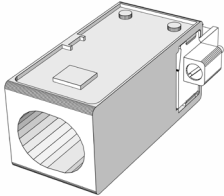
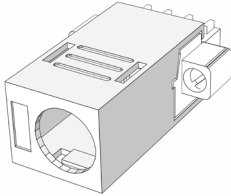
Cable Housing - Illustration	Cover Hood - Illustration
 KGG-MSTB 2,5/ 2 (2-pin) KGG-MC 1,5/ 5 (5-pin)	 BCZ 3.81 AH04 BK BX (4-pin) BCZ 3.81 AH05 BK BX (5-pin)
<p>For 2-pin and 5-pin: https://www.phoenixcontact.com/online/portal/us?uri=pxc-oc-itemdetail:pid=1803934&library=usen&pck=P-11-02-01&tab=1 https://www.phoenixcontact.com/online/portal/us?uri=pxc-oc-itemdetail:pid=1834372&library=usen&pck=P-11-02-01&tab=1</p> <p>For 4-pin and 5-pin http://catalog.weidmueller.com/procat/Product.jsp;jsessionid=B040D5EB6832629E567C884809FDF6C1?productId=(%5b1005290000%5d) http://catalog.weidmueller.com/procat/Product.jsp;jsessionid=D399022A1B3211C0146BCBE716D93211?productId=(%5b1005300000%5d)</p>	

General Installation Recommendations

Configuring Housing / Terminal Block connectors

Below is a brief illustration that might be useful during configuration and installation of such connectors. You will need suitable pre-configured cable(s) and tools to configure the connector(s) and cable(s) that are present in your installation environment. Below is a sample procedure for a 2-pin DC power connector. The procedure is the same for other connectors of this type as listed in table above. Unit used as illustration below is for reference only.

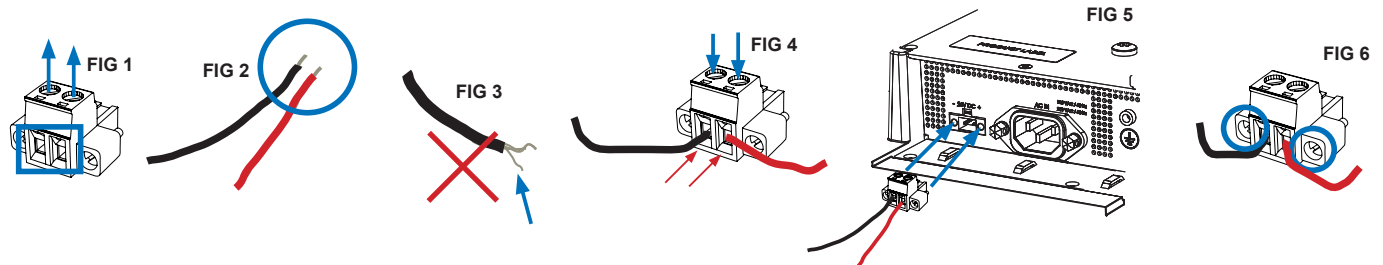

Requires assembly. It is expected that the technician has experience in electronics and assembling cables and connectors.

Warning: Do not connect or disconnect cables/connectors to the unit's connector while the unit is powered on. Failure to do so may result in damaged electronics.

FIG 1: Unscrew (from top) or make sure that the screw terminal is fully open, so you can secure the inserted cables correctly to the loose housing connector (it may already be plugged into the unit as per factory installation).

FIG 2: Strip carefully the insulation from the cable to expose the wire(s) inside.

FIG 3: Ensure that the wire(s) is without any loose threads to ensure good connection.

FIG 4: Insert cables* (from front) and screw / secure the cables by turning the screw on top of the housing to secure the cables properly. Check that the cables are firmly in place and do not appear loose or fall out when pulling gently.

**Note: Required polarization verification (for instance -/+ for DC power input) should conform with the markings on the connector area of the unit. Ignoring the markings on the unit or its add-on modules might damage the unit and/or external equipment in which end, warranty will be void.*

FIG 5: Plug the housing into the appropriate connector area of the unit (glass should be facing down) and check again that the cables secured conform with the markings on the connector area of the unit. Finalize the installation by fastening the screws located in front on each side of the housing connector (**FIG 6**).

Connector / Function	Recommended Cable Thickness
2-pin DC Power Input (Terminal Block 5.08)	Minimum 20 AWG - Maximum 18 AWG
4-pin CAN (Terminal Block 3.81)	Minimum 22 AWG - Maximum 20 AWG
5-pin NMEA COM (Terminal Block 3.81)	Minimum 22 AWG - Maximum 18 AWG
5-pin DIO (Terminal Block 3.81)	Minimum 22 AWG - Maximum 18 AWG

General Installation Recommendations

First Things First!

IND100148-5 - Rev 05

ATTENTION!
To prevent damage to chassis and glass, please review the illustrations !

CORRECT HANDLING!

Place horizontally on a smooth and clean surface (table with cloth)

WRONG HANDLING!

Do not stress the corners, nor place it on a coarse and/or dirty surface

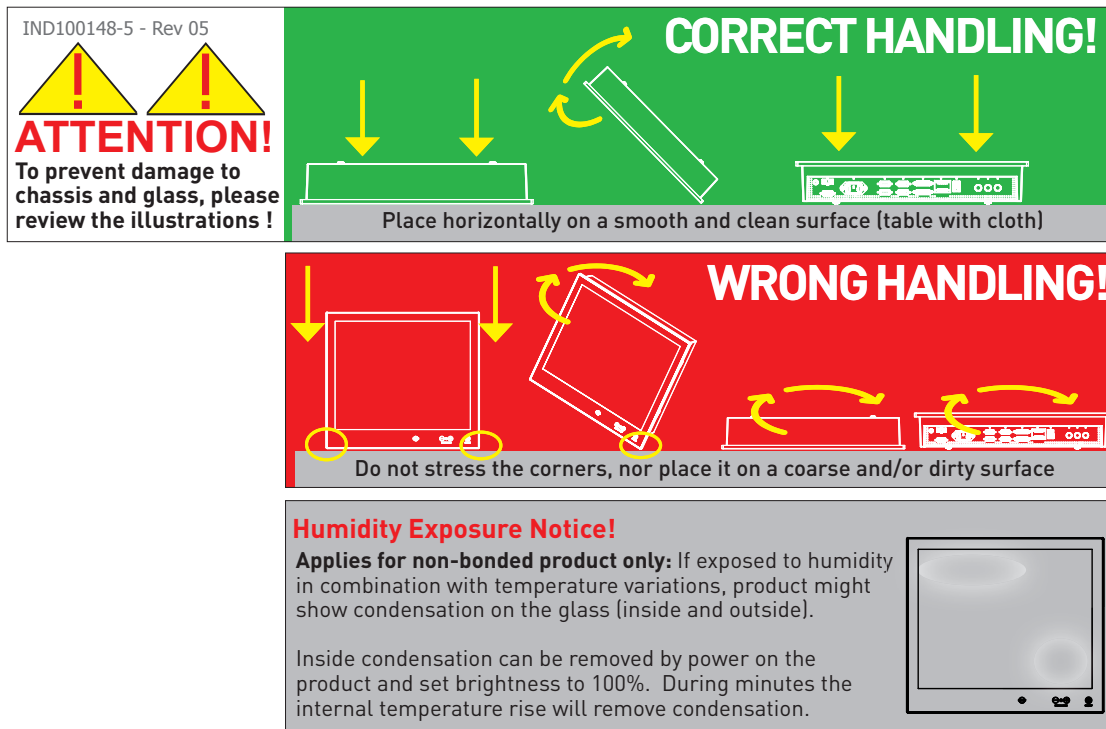

Humidity Exposure Notice!
Applies for non-bonded product only: If exposed to humidity in combination with temperature variations, product might show condensation on the glass (inside and outside).
Inside condensation can be removed by power on the product and set brightness to 100%. During minutes the internal temperature rise will remove condensation.



Installation and mounting

1. Most of our products are intended for various methods of installation or mounting (panel mounting, bracket mounting, ceiling/wall, console mounting etc.); for details, please see the relevant mechanical drawings.
2. Adequate ventilation is a necessary prerequisite for the life of the product. The air inlet and outlet openings must definitely be kept clear; coverings which restrict ventilation are not permissible.
3. Generally, do not install the unit in a horizontal position (laying down), as this will cause heat to build up inside the unit which will damage the LCD Panel. To prevent this problem we recommend installing the unit in a vertical position (± 30 degrees) to improve the airflow through the unit.
4. To further improve the thermal situation we recommend using forced air passing by the product. In some cases, convection based cooling can create "heat zones" around the product. This may be required in high temperature applications and also when there is reason to expect temperature problems due to non-optimal way of mounting.
5. Exposure to extreme direct sunlight can cause a considerable increase in the temperature of the unit, and might under certain circumstances lead to excessive temperature. This point should already be taken into consideration when the bridge equipment is being planned (sun shades, distance from the windows, ventilation, etc.). To maximize product life, it is recommended using Hatteland Technology's UV Sun Covers when the product is not in use.
NOTE! Long term direct sun exposure might have cosmetic impacts on the product, and damage the touch.
6. Space necessary for ventilation, for cable inlets, for the operating procedures and for maintenance, must be provided.
7. If the push buttons of the product are not illuminated, an external, dimmable illumination (IEC 60945 Ed. 4, 4.2.2.3, e.g. Goose neck light) is required for navigational use. The illumination should be free from glare and adjustable to extinction.

General Installation Recommendations

8. Information about necessary pull-relievers for cables is indicated in the Physical Connection section of this manual. Attention must be paid to this information so that cable breaks will not occur, e.g. during service work.
9. Do not paint the product. The surface treatment influences the excess heat transfer. Painting, labels or other surface treatments that differ from the factory default, might cause overheating.
10. Exposure to heavy vibration and acoustic noise might under certain circumstances affect functionality and expected lifetime. This must be considered during system assembly and installation. Mounting position must be carefully selected to avoid any exposure of amplified vibration.
11. Additional rules may apply to certain procedures where the symbols  and  are present. For more information, review "IEC62368 policy for Hatteland Technology product" section later in this manual.

Installation limitations

Due to environmental factors, please review the points noted below.

A: Overheat prevention:

For Maritime Multi Computer (MMC, Panel Computers) it is advised that you do not mount the unit in a vertical angle lower than ± 30 degrees, as noted in point 3 (previous section), i.e. flat mounting of the unit. This is to prevent both overheating the unit as well as ensure proper cooling airflow to sustain long-life and stable operation. Panel Computer units generate more heat than regular Display units naturally because of CPU and mainboard chips.

B: Glass Display Control™ (GDC) front glass touch buttons:

As this uses Projected Capacitive technology (instead of conventional hard physical buttons and knobs), the touch controller can react and is sensitive to raindrops (for outdoor installations). To ensure that raindrops do not stay on the unit's flat glass surface, please do not mount the unit in a vertical angle lower than ± 30 degrees, i.e. flat mounting of the unit. This is to prevent accidental touches that are similar to a human finger (cover area for a x period of seconds) as well as make sure the raindrops are "moving" and runs down off the glass surface.

For Maritime Multi Display (MMD) units (not available for Panel Computers (MMC) units), the angle could potentially be lower as the On Screen Display (OSD) menu offers a "OSD Key outdoor" function with 5 seconds delay before activation on front glass functions. Please review the "OSD Menu Functions" to learn more. In certain situations this might help, but is only suggested as a trouble-shooting tip during installation or during short-term observer use if found suitable. It should not be considered as a definitive trusted solution.

C: Projected Capacitive Technology (PCTouch) MULTITOUCH and in general Touch Screen glass:



For all units with a factory mounted touch screen and for outdoor use especially, please review point B above regarding standing raindrops. The only solution to this situation is not to mount the unit in a vertical angle lower than ± 30 degrees, i.e. flat mounting of the unit to ensure touch screen is not activated and accidentally automatically chooses functions in your running chart, radar or other software installed.

D: General rule for console mounted units:

To ensure proper cooling airflow, long-life and stable operation for all units, please make sure that the console casing has either fans or decent ventilation holes to prevent overheating inside the console due to the combined temperature of both Display or Panel Computer units together with other electronic instruments. A general rule is to make sure the console casing is capable of expelling "worst case scenario" in respect of the "Max Power Consumption" of all devices installed. Please review also point 2, 5, 6 and 9 (previous section) for additional information and installation tips.

General Installation Recommendations

General mounting instructions

1. The useful life of the components of all Electronics Units generally decreases with increasing ambient temperature; it is therefore advisable to install such units in air-conditioned rooms. If there are no such facilities these rooms must at least be dry, adequately ventilated and kept at a suitable temperature in order to prevent the formation of condensation inside the display unit.
2. With most Electronic Units, cooling takes place via the surface of the casing. The cooling must not be impaired by partial covering of the unit or by installation of the unit in a confined cabinet.
3. In the area of the wheel house, the distance of each electronics unit from the magnetic standard compass or the magnetic steering compass must not be less than the permitted magnetic protection distance. This distance is measured from the centre of the magnetic system of the compass to the nearest point on the corresponding unit concerned. The compass safe distance is specified in the corresponding datasheet
4. Units which are to be used on the bridge wing must be installed inside the “wing control console” protected against the weather. In order to avoid misting of the viewing screen, a 25 ... 50 W console-heating (power depending on the volume) is recommended.
5. When selecting the site of a display unit, the maximum cable lengths have to be considered.
6. When a product is being installed, the surface base or bulkhead must be checked to ensure that it is flat in order to avoid twisting of the unit when the fixing screws are tightened, because such twisting would impair mechanical functions. Any unevenness should be compensated for by means of spacing-washers.
7. Products with AC input must be grounded to protective Earth (Safety Ground) when necessary via the bolt (usually on terminal plate) available on the product.
Products with DC input must be grounded to protective Earth (Safety Ground) via the bolt (usually on terminal plate) available on the product.
A shorter and thicker cable gives better grounding. A 6mm² is recommended, but a 4mm² or even 2.5mm² can be used for this purpose.
8. Transportation damage, even if apparently insignificant at first glance, must immediately be examined and be reported to the freight carrier. The moment of setting-to-work of the equipment is too late, not only for reporting the damage but also for the supply of replacements.
9. The classification is only valid for approved mounting brackets provided by Hatteland Technology. The unit should be mounted stand-alone without any devices or loose parts placed at or nearby the unit. Any other type of mounting might require test and re-classification.
10. Additional rules may apply to certain procedures where the symbols  and  are present. For more information, review “IEC62368 policy for Hatteland Technology product” section later in this manual.

General Installation Recommendations

Ergonomics

1. The front surface of the display glass has an anti-reflective (AR) coating which can be scratched and damaged with improper cleaning. It is recommended using only 90+% pure Isopropyl alcohol (Isopropanol) and a soft fabric cloth for this first cleaning. Fold a cloth into a small pad, dampen the cloth with alcohol, and wipe the glass from one edge to the other in one direction with one continuous motion. The product glass will require cleaning as needed. The soft cloth & alcohol wipe is recommended to clean fingerprints and oils off the glass. Water stains (including coffee, tea & coke) should be first cleaned off the glass with a soft fabric cloth wet with water, immediately followed with wiping using an alcohol wetted cloth.
2. Adjust the unit height so that the top of the screen is at or below eye level. Your eyes should look slightly downwards when viewing the middle of the screen.
3. Adjust screen inclination to allow the angle of gaze to remain at the centre of the screen approximately perpendicular to the line of gaze.
4. When products are to be operated both from a sitting position and from a standing position, a screen inclination of about 30° to 40° (from a vertical plane) has turned out to be favourable.
5. The brightness of displays is limited. Sunlight passing directly through the bridge windows - or its reflection - which fall upon the screen workplaces must be reduced by suitable means (negatively inclined window surfaces, venetian blinds, distance from the windows, dark colouring of the deckhead). However, units can be offered with optical enhanced technology and/or High Bright panels to reduce reflections and are viewable in direct sun light, but as a general rule the units at the bridge wing area are recommended to be installed or mounted by suitable alignment or bulkhead / deckhead mounting in such a way that reflections of light from the front pane of the display are not directed into the observer's viewing direction.
6. The use of ordinary commercial filter plates or filter films is not permitted for items of equipment that require approval (by optical effects, "aids" of that kind can suppress small radar targets, for example).
7. For ECDIS applications, the minimum recommended viewing distance are as follows:
(IEC62288, Part 7.5 Screen resolution)

17 inch = 907mm	19 inch = 1010mm	24 inch = 951mm	26 inch = 985mm	27 inch = 1070mm	
-----------------	------------------	-----------------	-----------------	------------------	--

General Installation Recommendations

Cables

Use only high quality shielded signal cables.

Cable Entries & Connectors (Marked area)

Illustration below for smallest/largest sizes only.

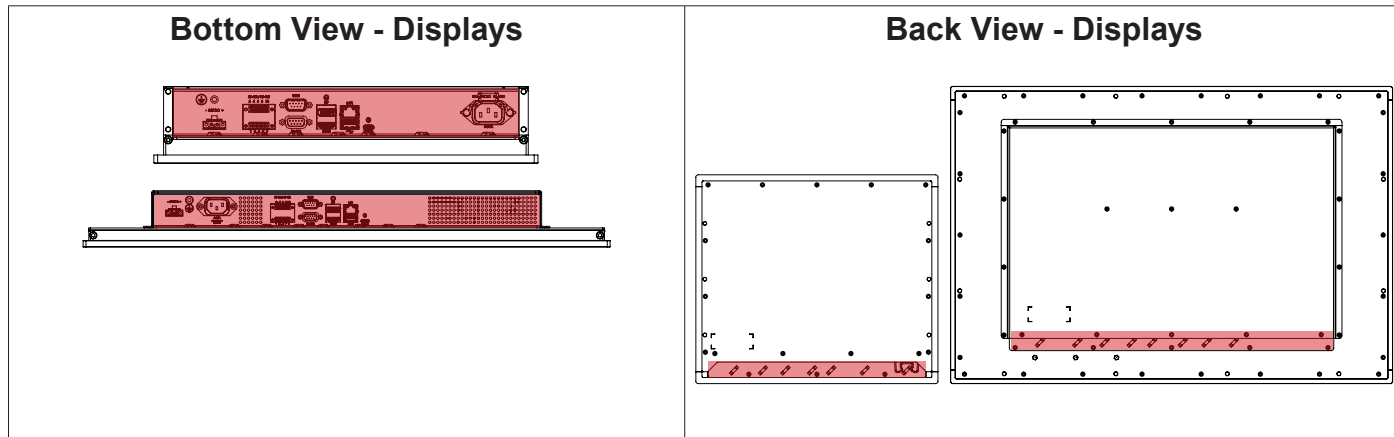

Maximum Cable Length

Any cable should generally be kept as short as possible to provide a high quality input/output. The maximum signal cable length will depend not only on the signal resolution and frequency, but also on the quality of the signal output from the computer/radar.



Panel Cutout / Console Mounting Bracket Kit for 15, 17 and 19 inch

You need: Hex tool (6mm), 2 pcs of HD CMB SX2-A1 Kit (included in delivery). Procedure suitable for: Display and Panel Computers. Brackets are EN60945 Tested. 19 inch Maritime Multi Display (MMD) used as example below.



Attention: A suitable pre-cut panel cutout should be made prior to mounting. Do not force the unit into the panel cutout as it might break the outer glass or scratch the chassis on the unit. Make sure that the panel cutout is not too tight for the unit. Please disconnect ALL cables before proceeding. Please re-check the relevant and required panel cutout measurements if unsure.

▼ 1: Mount one of the flat brackets on any side on rear of unit first with 3 x M5x12 Countersunk Hex screws as illustrated and fasten it using Torque Force 3.75Nm

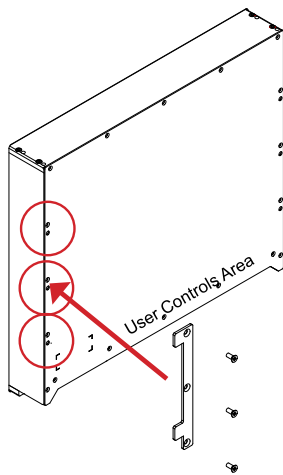

▼ 2: Tilt the unit 45 degree to allow the flat bracket to enter cutout first, then tilt it back 45 degree and slide the entire unit into the cutout evenly and carefully. User Controls and Connector Area should be facing downwards.

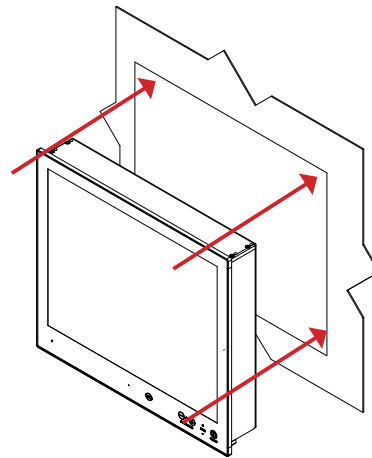

▼ 3: Once unit is in place, mount the other flat bracket on the other side with 3 x M5x12 Countersunk Hex screws as illustrated and fasten it using Torque Force 3.75Nm

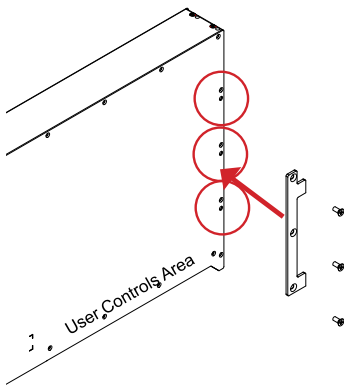

▼ 4: Prepare 4 pcs of Thumb screw and Mounting Socket Nut in separate form as illustrated below.

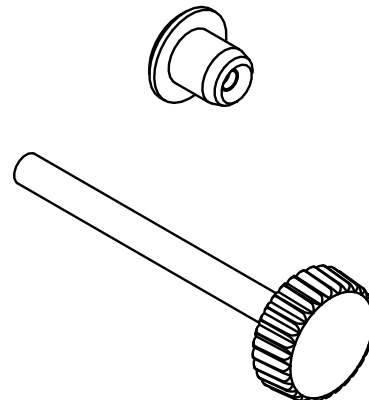



▼ 5: Mount the Thumb Screw and Mounting Socket Nut through each of the flat brackets threaded holes as illustrated and fasten the Mounting Nut tight at the end.

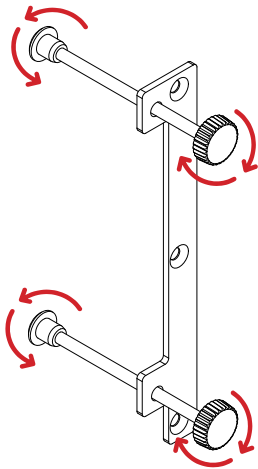

▼ 6: Finally, in a even way fasten each of the 4 Thumb Screws to securely fasten the unit to the rear of the Panel Cutout.

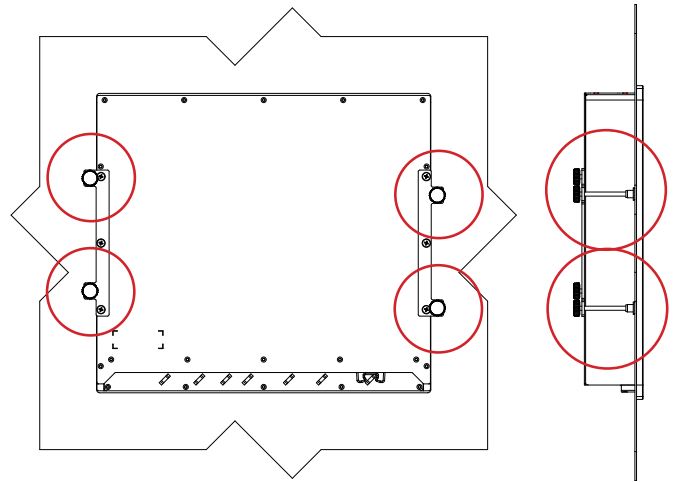

▼ 7: The Console Mounting Kit also allow to edge-to-edge mounting of two units, due to the intersection design of the flat brackets on the rear. Example below illustrates the intersection.

Front View

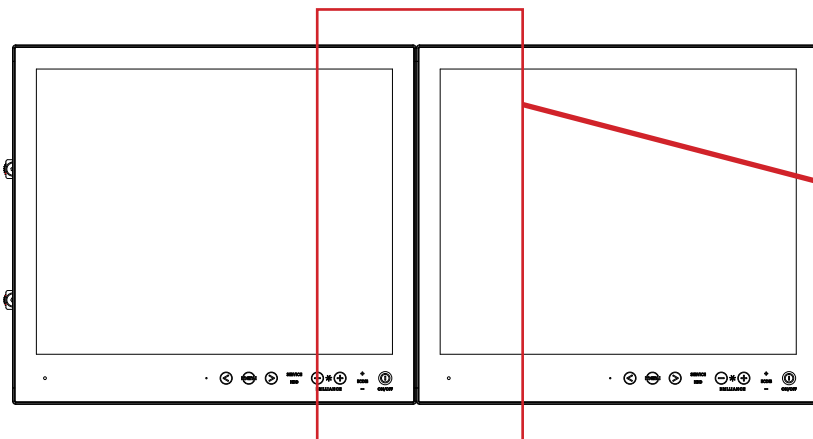

Rear Details

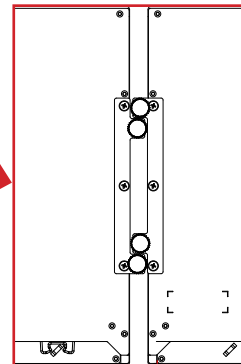



Panel Cutout / Console Mounting Bracket Kit for 24 and 27 inch

You need: Torx T25 tool, 1 pcs of HD CMB SX2-E1 kit (included in delivery).

Procedure suitable for: Display and Panel Computers Series X Generation 2 range. Brackets are EN60945 Tested.



Attention: A suitable pre-cut panel cutout should be made prior to mounting. Do not force the unit into the panel cutout as it might break the outer glass or scratch the chassis on the unit. Make sure that the panel cutout is not too tight for the unit. Please disconnect ALL cables before proceeding. Please re-check the relevant and required panel cutout measurements if unsure.

Item	Amount	Art	Description	Notes
	3	P006858-1	Bracket HD 24T21 SH-A	
	1	P020605	HD 2xT2x CMB Bottom	
	6	145 050x016 A4T	M5x16 Pan Head screw ISO 14583 Torx, A4	For P006858-1
	6	144 064x120x22	M6 C-washers DIN6319 Steel	For P006858-1
	2	145 050x016 CA4	DIN 965 M5x16 Countersunk head screws with TX25, A4 STAINLESS STEEL	For P020605

▼ 1: Slide the unit into the cutout carefully. User Controls and Connector Area should be facing downwards.

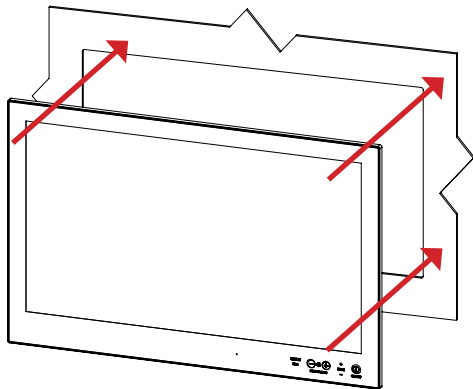

▼ 2: Make sure you are aware that brackets should be mounted on TOP, LEFT, RIGHT and BOTTOM sides. Note that the [B] bracket is different than the [A] brackets and mounted near the connectors. See closeup of details.

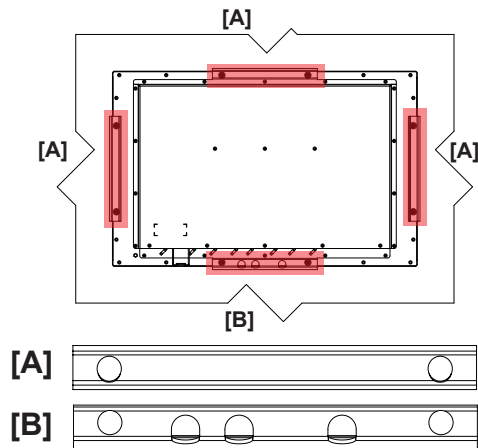

▼ 3: Secure each bracket with the provided screws as illustrated below. Make sure you do it equally and even for all 4 sides. Use Torque Force 3.75Nm. Note the orientation of brackets before you begin.

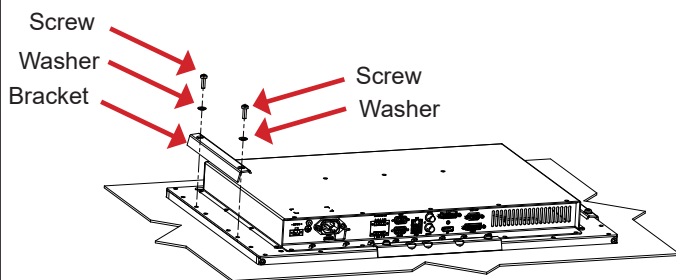

▼ 4: Review closeup of the mounting of brackets with screws. Seen from bottom side.

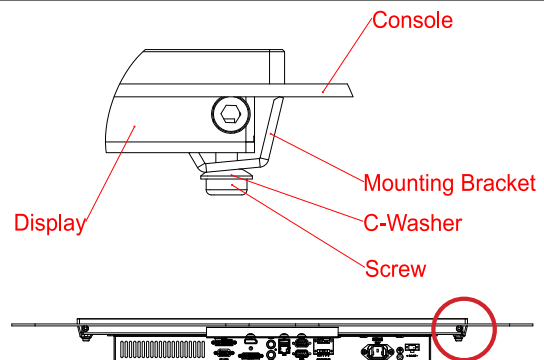



Mounting Bracket, Table / Desktop / Ceiling - 15, 17 and 19 inch

Procedure suitable for: Display (MMD) and Panel Computer (MMC) Series X Generation 3 (G3) product ranges.
19 inch Maritime Multi Display (MMD) used as example below.

You need:

- M3 Unbrako® Hex Key tool (not included with delivery).
- Fasteners (6 pcs M6) for mounting complete unit onto table or desktop location (not included with delivery).
- 1 pcs of HD TMB SX2-A1 Mounting Bracket Kit (including pre-mounted 6 x M6x6mm Set Socket Screws).



Attention: Please disconnect ALL cables before proceeding. Please review User Manual or visit www.hattelandtechnology.com for Technical Drawings regarding measurements for both main unit and Mounting Brackets.

▼ 1: Place the unit on a dry, flat, clean, soft surface (i.e. table) with the glass front facing down as illustrated. Connector area should be facing downwards from you.

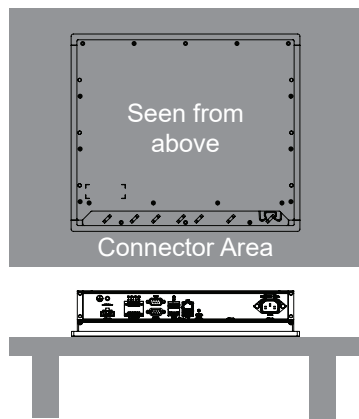

▼ 2: The two bracket pieces comes pre-mounted as shown below. Both sides are identical. Prepare the drilling, location of holes indicated in the footprint below. Drill 6 pcs of 6mm holes in your table/desktop location.

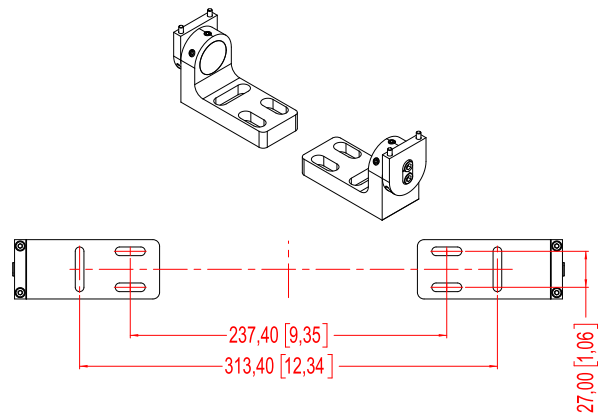

▼ 3: Identify the 3 x Set Socket Screw (M6x6mm) and slightly loosen two of them, now tilt the upper part until you reach an approximate position you need and tighten them slightly.

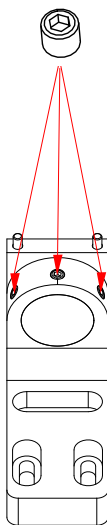

▼ 4: Mount the brackets onto unit as indicated with 2 pcs M4x35 DIN912 screws (included) on both sides. Use Torque Force 2Nm.

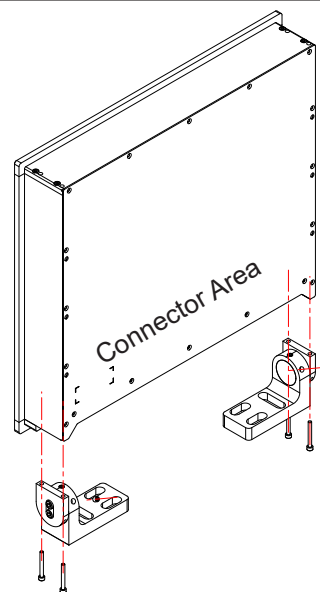



▼ 5: Please note the Factory Mounted Torx screws on both bracket sides, THESE ARE NOT TO BE ADJUSTED OR LOOSENED!

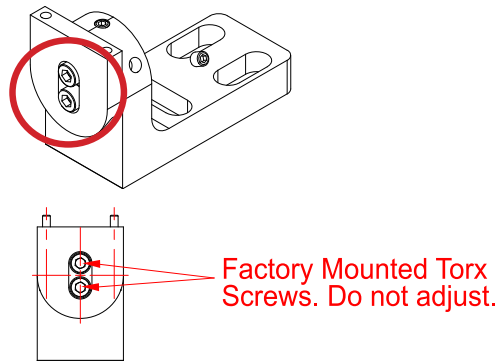

▼ 6: Fasten the complete unit to your table/desktop location, and tilt it into the desired position. Locate the Set Socket Screws on both brackets described in step 3. Secure all 3 Set Top Screws on both sides, use Torque Force 7Nm on all. If you need to re-adjust the tilting later, place your hand on top of the Display/Panel Computer unit to keep it steady, and loosen minimum two of any Set Top Screws on both brackets, adjust unit into new tilting angle, and fasten the Set Top Screws again. Verify that the unit does not tilt by itself and appear fixed in-place.

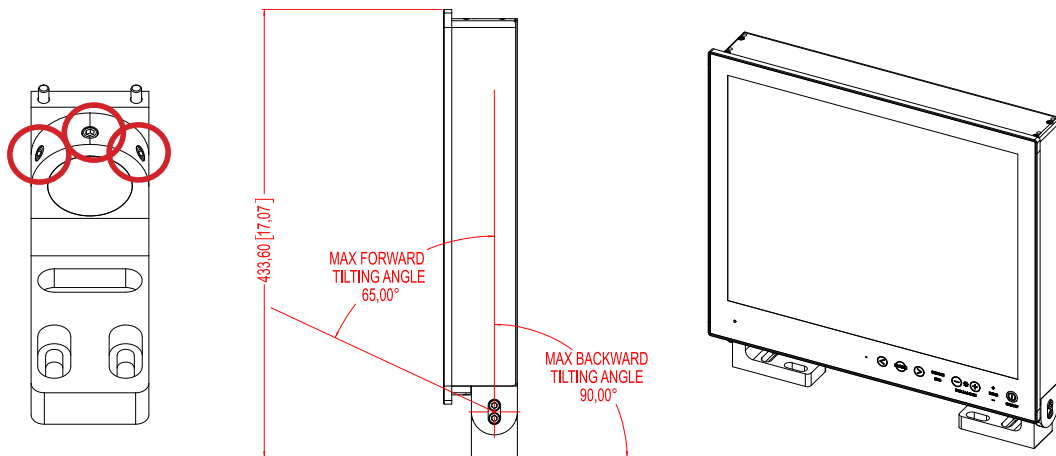

▼ ▼ Alternative Mounting: Depending on installation needs, you may mount the complete unit in ceiling in two different ways.

Upside Down Position: User Controls will be upside down, cables go straight up. You may configure Glass Display Control™ (GDC) LED symbols to show or not, since symbols will be seen upside down. Displayed image needs to be flipped vertically. Review the appropriate SCOM manuals ("Glass Display Control™ (GDC) LED & Button operations" section).

Normal Position: User Controls readable, no image flip needed, cables has to bend up or go straight down.

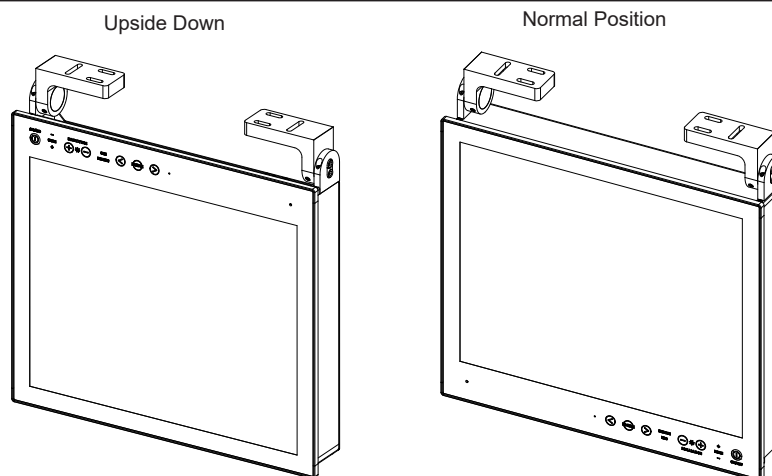



Mounting Bracket, Table / Desktop / Ceiling - 24, 26 and 27 inch

You need: M5 Unbrako® Hex Key tool and 1 pcs of HD TMB SX1-C1 Mounting Bracket Kit. Fasteners (6 pcs M6) for Table / Desktop location not included. Procedure suitable for: Display and Panel Computers. 24 inch unit used as illustration below, but same procedure apply for 27 inch units as well.



Attention: A suitable pre-drilled location should be prepared and checked prior to mounting. Please disconnect ALL cables before proceeding. Please review User Manual or visit www.hattelandtechnology.com for Technical Drawings regarding measurements for both main unit and Mounting Brackets.

▼ 1: Place the unit on a dry, flat, clean, soft surface (i.e. table) with the glass front facing down as illustrated. Connector area should be facing downwards from you.

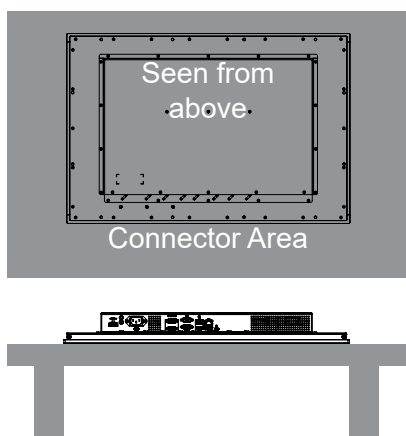

▼ 2: Inspect the mounting holes of brackets. For mounting to a 24 inch unit, please use the **lower holes** as indicated. For mounting to a 26 / 27 inch unit, please use the **upper holes** as indicated.

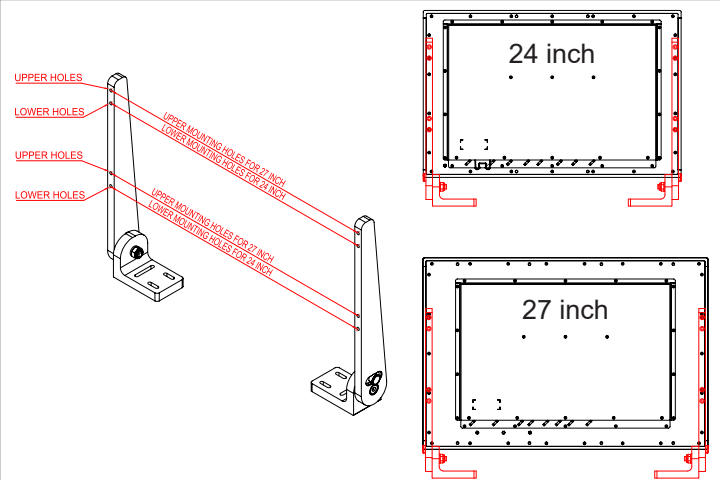

▼ 3: Place one bracket at the time with the mounting holes facing down into the suitable mounting position and fasten with 2 x M5 screws on each bracket. Torque Force 3.5Nm.

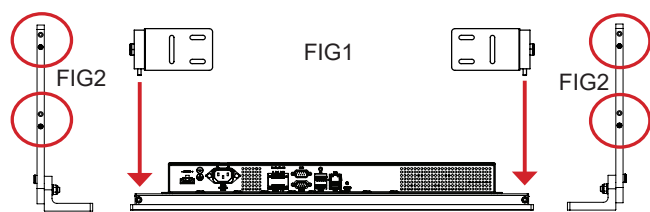

▼ 4: While unit is lying flat on table, check the Tilting Lock Pin position. These can be pulled out by hand, turned 90° (FIG1) and turned back 90° until the Lock Pin automatically clicks into place by a spring (FIG2).

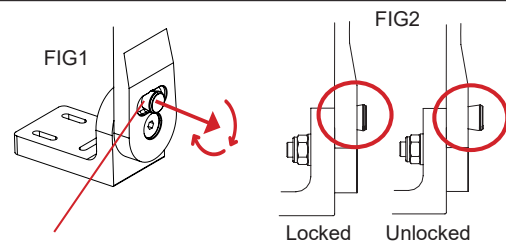

▼ 5: You may now mount the unit onto your desired location. It is advised that you unlock the Lock Pin (as shown in step 4), tilt the unit 90° backwards (FIG1) and properly fasten the bracket base into location (FIG2).

NB! Be careful not to break or scratch the edge of the front glass! Then repeat step 4 again until your desired tilting position has been achieved and you have verified that the Lock Pin are in locking position and the unit is firmly attached and does not appear loose (FIG3).

Installation Procedures

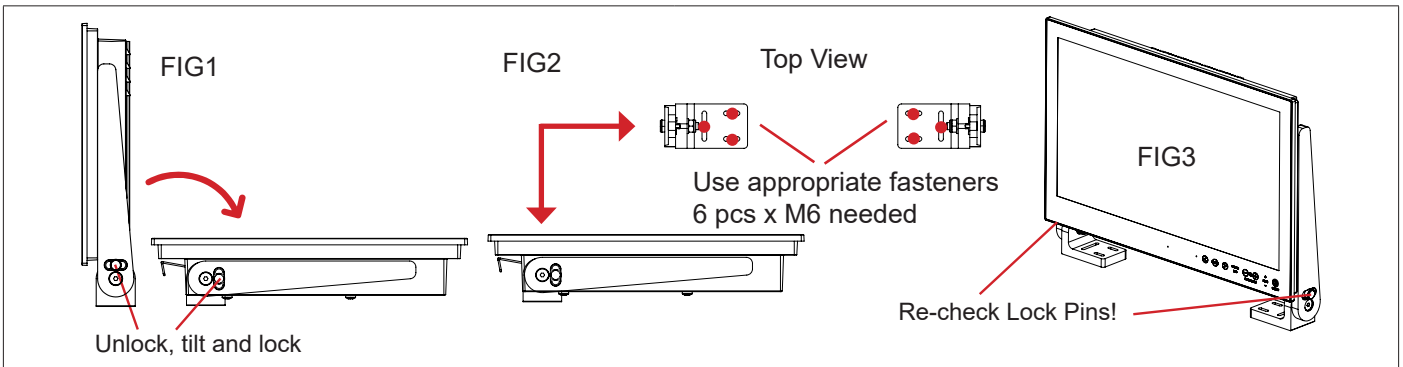

▼ Alternative Mounting: Depending on installation needs, you may mount the complete unit in ceiling in two different ways.

Upside Down Position: User Controls will be upside down, cables go straight up. You may configure Glass Display Control™ (GDC) LED symbols to show or not, since symbols will be seen upside down. Displayed image needs to be flipped vertically. Review the appropriate SCOM manuals ("Glass Display Control™ (GDC) LED & Button operations" section).

Normal Position: User Controls readable, no image flip needed, cables has to bend up or go straight down.

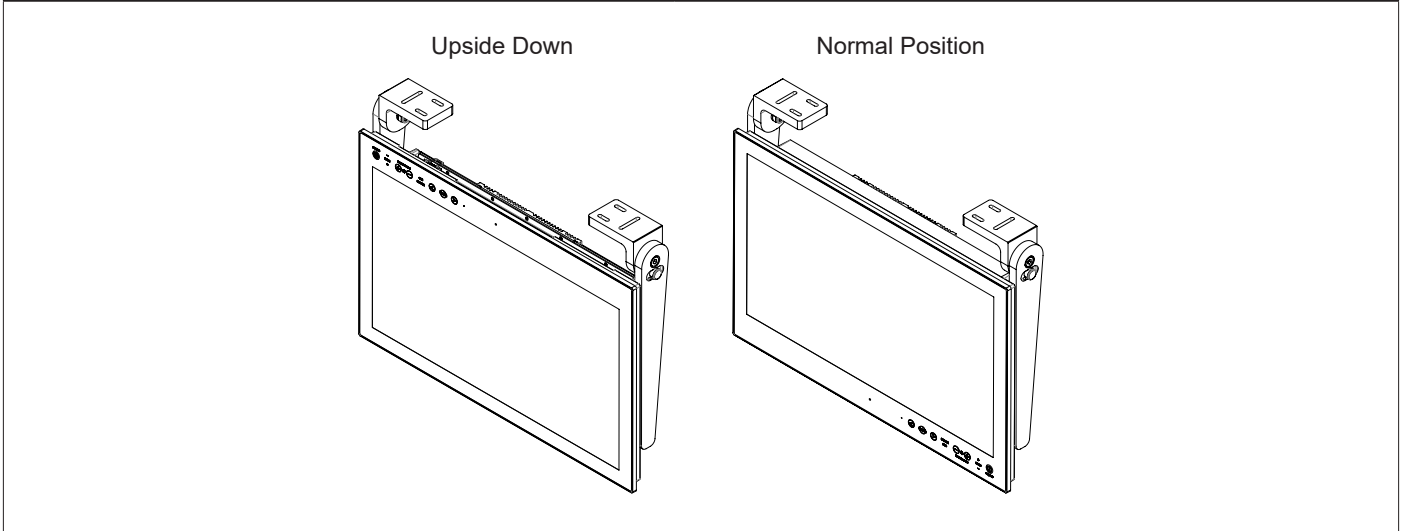

Physical Connections

Connection area of unit (illustration)

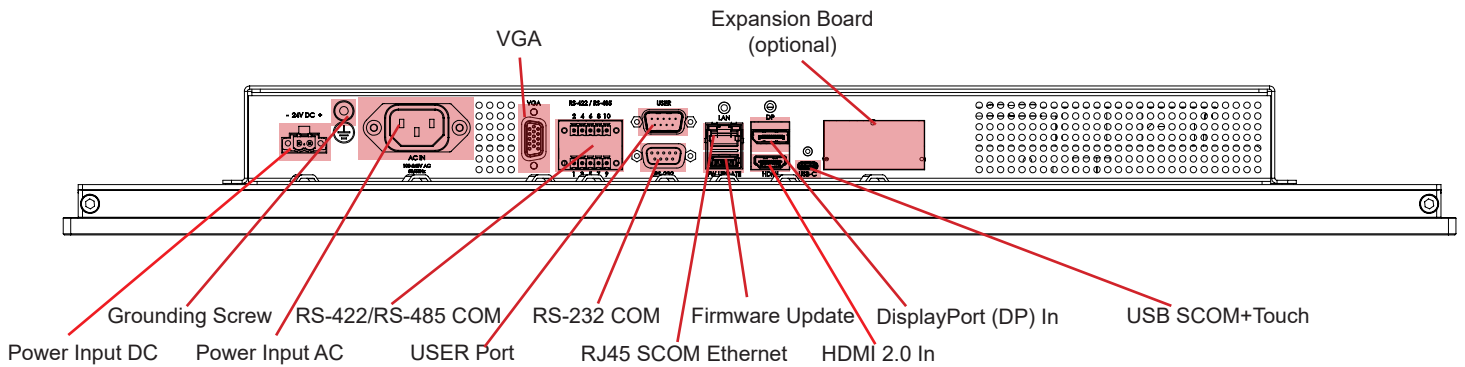

Note: 27 inch unit used as example above, please review specifications for your actual model.

Reduce Cable Tension

To reduce tension on the cables you connect, secure them with a cable tie to the available chassis hinges located near the connectors.

Note: Amount of chassis hinges can vary depending on model.

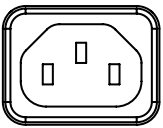

POWER INPUT:

The internal AC power module supports both 115VAC/60Hz and 230VAC/50Hz power input. Please check specifications for your unit.

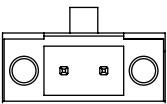

- +

POWER INPUT:

Connect your DC power cable to the 2-pin Terminal Block 5.08 connector. The internal DC power module supports 24VDC. For more information, please review "Housing Connector Overview" earlier in this manual.



GROUNDING SCREW:

Please review "General mounting instructions" in the "Installation" chapter, pt. 7 for more information.

Note for Grounding Screws: Standard Grounding Screw/Bolt provided by Hatteland Technology is "Pan head screws M4x8mm w/spring and plainwasher".

Multi-power note: (For units supporting AC & DC input simultaneously)

The unit has a dual input power supply which will accept both AC and DC input. If both inputs are connected, the unit will be powered by AC. If AC is disconnected it will automatically switch over to DC without affecting the operation of the unit. This makes it possible to use AC power as primary power and a 24V battery as secondary power, eliminating the need for expensive UPS systems.

Physical Connections

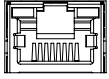

Network/LAN INPUT / OUTPUT (NET A):

Supports 10/100/1000Mbps Ethernet (LAN). Suitable for twisted pair cables CAT.5E. Make sure the network cable connector "clicks" into the RJ-45 connector. This connector will allow remote control via SCOM of the display unit to control common functions like brightness, input source and more.



USB2.0 FW (Firmware) Update:

Intended for on-site possibility to upgrade/service the internal Firmware inside the unit that could fix issues or to improve functions for either Video Controller or Glass Display Control™ (GDC). Upgrading should only be performed by a skilled technician familiar with typical Firmware/Bios upgrading. Insert a TYPE A USB Memory Stick into this connector.

Firmware package is available on request from Technical Support - support@hattelandtechnology.com - Please provide full type and serial number!

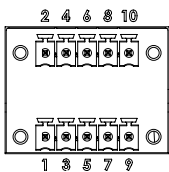

RS-422 / RS-485 COM I/O:

The COM (non-isolated RS-422/485) allows functionality to communicate with serial based equipment including controlling internal buzzer externally. Connect and fasten your cables from your compatible external equipment to the 5-pin Terminal Block 3.81 connector. Please review the "Pinout Assignments" chapter as well as "Housing / Terminal Block Connector Overview" in this manual for more information.



HDMI 2.0 IN:

Connect your HDMI (male) cable to the HDMI 2.0 19P connector (female) of the unit. The HDMI connector has its own locking mechanism that locks the plug inserted. Make sure the plug "clicks" into place to verify a proper and secure connection. For optimal signal quality and stability, use HDMI 1.4/2.0 compliant cable.



DisplayPort 1.4 (DP) IN:

Connect your DP (male) cable to the DisplayPort (v1.2) 20P connector (female) of the unit. The DP has its own locking mechanism that locks the plug inserted. Make sure the plug "clicks" into place to verify a proper and secure connection.

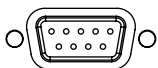

RS-232 COM I/O:

This D-SUB 9P connector (female) provides additional functionality for the unit. The Serial Remote Control features a RS-232 (non-isolated) interface for controlling internal parameters like brightness. You can access most of the parameters available in the OSD menu and with special commands control the unit externally. Fasten your external cable to the D-SUB 9P connector (female) using the provided screws on the cable housing.

Please review "Management Settings/Communication" in the "OSD Menu Functions" chapter for more information.

Physical Connections

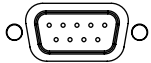

USER Port INPUT / OUTPUT:

Allows for controlling Brightness of the displayed image on screen and power the screen On/Off, by connecting an external remote control to the D-SUB 9P connector (male). The USER port has built in Potentiometer IN, +5VDC OUT, external power button, +12VDC OUT and BRT +/- IN functionality. Review the “Pin Assignments” chapter in this manual for more information on how to activate this functionality. Do not connect/disconnect cables to this connector while product is powered on.



USB-C DP 1.2 IN and USB2.0 (SCOM and touch):

This USB-C connector supports DP and USB 2.0 for SCOM and touch (if factory-installed) simultaneously. All three features can be utilized concurrently when using compatible cables provided by Hatteland Technology. For additional secure mounting, consider using the provided “ATEN LockPro Cablelock”.

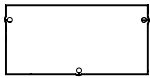

Expansion Board (factory option)

This is an option to choose different types of expansion boards to extend the I/O capabilities of the monitor. See the available options in doc IND100133-106.

Physical Connections



EXPANSION AREA for Optional modules:

It is possible to install one optional expansion board to extend the I/O of the monitor. The available option is listed in the table below. It is also possible to create a custom card based on requirements; however, there are limitations to what is possible. For more information, please contact your local sales representative.

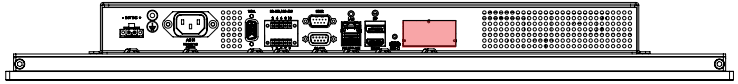
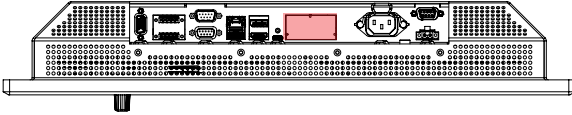

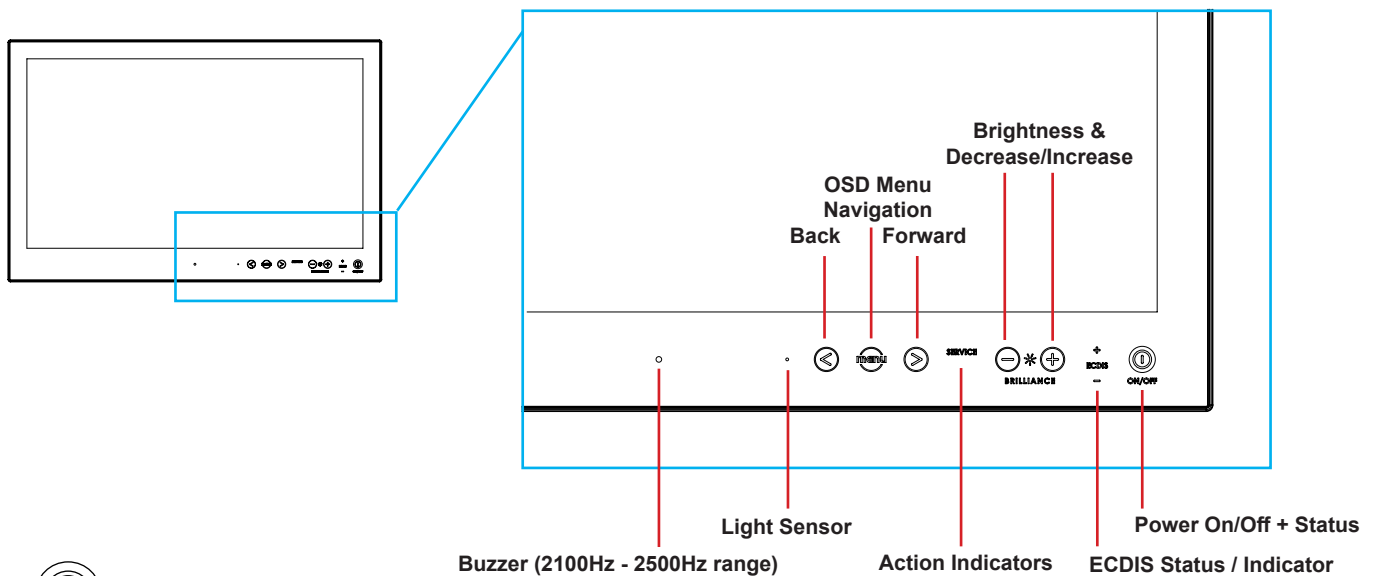

Illustration	Description
	<p>Typenumber: VIC2-EBDVI-1 R01 DV1x1 expansion board for VIC2</p>

User Controls

USER CONTROLS OVERVIEW

The units are designed using Glass Display Control™ (GDC) touch technology to allow interactivity adjusting brilliance (brightness) and control power on / off with the use of illuminated symbols. Note that these symbols are only visible (backlight illuminated) when suitable power is connected, except for the power symbol which has a white silk print to indicate its position on the front glass. Further, not all symbols are available depending on factory options and product sizes (where applicable). There are no physical moving knobs, potmeters, wheels or push buttons available as everything is touch surface controlled by Projected Capacitive technology that allows a human finger (including several types of gloves) to control the unit.



ON/OFF

Power ON/OFF:

This symbol and all text will illuminate in red when suitable power is connected and the unit is turned off. When the unit is on and operating, this symbol will illuminate constantly either in yellow color (signal not recognized/not present and no image on screen) or green color (signal detected and image on screen).

Power ON:

To turn the unit on, verify that the symbol is illuminated in red (indicates suitable power is connected) and touch the power symbol and hold until the the symbol changes to green light/yellow light or a image appears on the screen.

Power OFF:

To turn the unit off, touch the power symbol and hold until it either illuminates/changes from green/yellow to red or the image on screen disappears.



OSD Menu, Navigation:

If the OSD (On Screen Display) menu was activated (and is clearly visible on screen), both the “<” and “>” are used to navigate, set options and change values within the OSD menu.

To access the main OSD menu, touch anywhere on the “MENU” circle symbol and the OSD menu will clearly be seen as an overlay over the existing displayed image. The complete definition of all the menus and functions are available in the “OSD MENU FUNCTIONS” chapter in this manual.

User Controls

SERVICE **Action Indicators:**
 SERVICE = Reserved for future use, no built-in function defined.



Brightness Adjust:
 Brilliance / Brightness adjustment of the displayed image is adjusted by touching the (-) or (+) illuminated symbols. The entire area of text and symbols are visible as long as the unit is powered. Note that only the (-) and (+) are touch sensitive while the "*" and "BRILLIANCE" symbols are not.

+ ECDIS - ECDIS Status / Indicator: (optional factory standard)
 For units that have been factory ECDIS calibrated the text "ECDIS" will illuminate in green constantly as long as the unit is powered. The "+" and "-" symbols will illuminate in orange when the Brightness/Brilliance is adjusted either above or below ECDIS factory calibration point.

To be able to stay within ECDIS calibrated range, please assure that both the "+" and "-" are not illuminated in orange color and that "ECDIS" text remains illuminated in green during operation. Note that by touching these symbols no action will be performed or has been assigned.

Note: ECDIS functionality is mostly only suitable for model sizes above 15 inch units.



 **Light Sensor:**

Used to sense level of ambient light in the surrounding environment. The sensor data can be read by suitable software through the Hatteland Technology SCOM functionality of the unit and thus can be used to control brightness remotely. Note: This sensor is barely visible to the eye and lies under the glass. It has no illumination behind to indicate it's position. Touching or covering this area will naturally make the sensor data inaccurate and should be avoided!

 **Buzzer:**

Only functional for units ordered with Buzzer functionality. The location of the buzzer hole (physical hole in glass) is barely visible to the eye. Touching this area will naturally mute buzzer sound or in some cases make it lower or change audible frequency. In no circumstances should this area be blocked by either stickers or objects! Please review the "Pinout Assignments" chapter in this manual for controlling the Buzzer functionality.

Note:
 In the following "On Screen Display (OSD)" menu chapter, these buttons are referenced as:

	"MENU"
	"(-) Brilliance (+)"
	"(<) Navigation (>)"

Note: GDC Symbols on front glass will by factory default fade away if signal input was lost, cable detached etc. Review OSD Menu function, "Keep OCM Mode" and its settings of "On" and "Off" meaning.

OSD Menu Overview

On Screen Display (OSD) Menu Introduction

The OSD menu consists of main menus and submenus which are very easy to navigate through. All functions are explained in-depth later in this user manual. Prior to using the OSD menu, you should be sure to familiarize yourself with how to physically access the menu, how to navigate up/down/left/right, how to modify values, exiting menus and more.



Please note: Factory default illustrations only! Available functions, icons and text may deviate slightly from actual OSD menu on your product due to different OSD software configurations and customized solutions.

OSD Key Code (password) overview





During use/accessing the OSD menu, based on factory default or customized configuration, there might be a pop-up requester asking for a Key Code (password) to gain further access to requested menu. These are 3 digits long.

Keycode	Description
321	Applies for "ECDIS Compliance" products. Code must be entered to get access to OSD MENU. Configured in OSD parameter: "OSD Settings > OSD Lock Mode > Menu Protect"
362	If OSD are in Basic Mode, entering code gets access to Advanced Mode. Configured in OSD parameter: "OSD Settings > OSD Mode > Advanced"
---	Service Mode - Only applicable for authorized service personnel. Configured in OSD parameter: "OSD Settings > OSD Mode > Service"

OSD Menu Overview

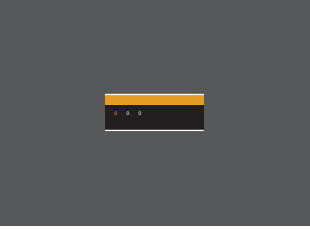
OSD Keycode / OSD Lock Mode

During use, a small requester may pop-up on screen asking you for a “Key Code”. This is a safety feature (due to ECDIS Compliance) that might be predefined in your setup. To quickly understand how to enter a code, navigate and finally access the underlying main menu, simply follow the illustration below. The “Key Code” is factory default set to “321”. If the “Key Code” requester do not appear on screen, you can skip reading this section for now and proceed to the next page.

 <p>Active Display Area + Requester</p>	 <p>Close-up of Requester</p>	 <p>Close-up of Requester</p>
<p>1: Typical position of requester on screen. Yellow box indicate number position, default location is always on first number.</p>	<p>2: Enter first number (from 0 to 9). Use “Navigation/Hot Keys” touch buttons to increase/decrease. Number change in real time.</p>	<p>3: Now touch menu button to store first number and proceed to second number. Yellow bar will move its position too.</p>
 <p>Close-up of Requester</p>	 <p>Active Display Area + OSD Menu</p>	
<p>4: Repeat step 2 and 3, until “Key Code” reads “3 2 1” and finally touch menu button to continue.</p>	<p>6: The OSD menu appear by default in the middle of Active Display Area</p>	

After the code is successfully entered you will gain access to the OSD Menu and a multitude of functions will be available for adjusting or reviewing. Please proceed to the next page, where you will learn the differences between the different menu modes and a complete map of all the underlying functions available within.

OSD Menu Overview

OSD “Basic”, “Advanced” & “Service” Menu modes

Three OSD Modes are available. The “Basic” Menu mode offers easy and clear access to most commonly used functions. The “Advanced” Menu mode offers a more advanced menu with technical information and is suited for more technical minded users and the “Service” Mode reveals more options in “Service settings” for service purposes. “Advanced” and “Service” modes are password (KeyCode) protected. Password for Advanced Mode is “362”, Password for Service Mode is intentionally only available from Service Partners and our HelpDesk which should only be used by experienced personnell. Please contact your Service Partner or our HelpDesk to retrieve the password.

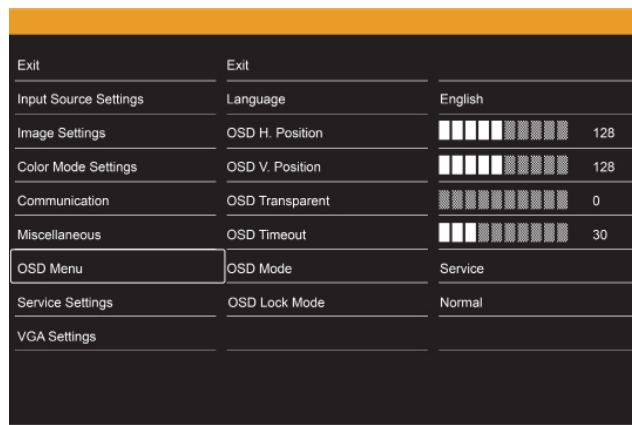

OSD Menu showing for example “OSD Menu Settings” chosen in the menu. The left menu bar is visible at all times, while the right section will change based on contents of that submenu. The design and size of OSD menu area does not change, even in any of the “Basic”, “Advanced” and “Service” mode settings.

OSD Menu Overview

OSD Menu Structure

In this table all functions within menus and their submenus are shown. Functions that begins with an asterix (*) and in **bold/red font color** style indicates this function/menu is only available during “Advanced” menu mode. Functions that begins with an asterix (*) and in **bold/blue color** indicates this function is only available while in “Service” menu mode. Functions with a “>” in the end, indicates a submenu or list of options will be displayed. Depth of the sub-menus (levels) are identified from 1 to 3.

Exit

Level 1 (Main Menu)	Level 2
Exit	Input
	Resolution
	H/V Freq
	Type Number
	Serial Number

Input Source Settings

Level 1 (Main Menu)	Level 2	Level 3	Default
Exit			
Input Source Settings >	< Exit		
	Main Input >	VGA, DP, USB-C, HDMI	USB-C
	Auto Source >	ON OFF	ON

Image Settings

Level 1 (Main Menu)	Level 2	Level 3	Default	Comments
Image Settings >	< Exit			
	*Aspect ration >	Full 4:3 16:9	Full	Only available for 19, 21,24 and 27
	*Brightness >	0 ~ 255	128	
	*Contrast >	0 ~ 255	128	
	*H Position >	0 ~ 255	(Variable)	
	*V Position >	0 ~ 255	(Variable)	
	*Clock >	0 ~ 255	128	
	*Phase >	0 ~ 255	128	

OSD Menu Overview

Color Mode Settings

Level 1 (Main Menu)	Level 2	Level 3	Default
Color Mode Settings >	< Exit		
	*Gamma >	No Calibration Calibration RGB Calibration DP Calibration USB-C Calibration HDMI Calibration SDI	No Calibration
	Color Temp >	9300 8000 6500 USER	8000
	*Saturation >	0 ~ 255	128
	*HUE >	0 ~ 255	128
	*Sharpness >	0 ~ 255	128
	Red >	0 ~ 255	128
	Green >	0 ~ 255	128
Blue >	0 ~ 255	128	

Communication Settings

Level 1 (Main Menu)	Level 2	Level 3	Default
Communication >	< Exit		
	*RS422/RS485 >	RS422-4WIRE RS485-2WIRE	RS422-4WIRE
	*RS Address >	0 ~ 255	0
	*DHCP >	ENABLE DISABLE	ENABLE
	*IP Address >		0.0.0.0

OSD Menu Overview

Miscellaneous Settings

Level 1 (Main Menu)	Level 2	Level 3	Default
Miscellaneous >	< Exit		
	*Key Out Door >	ON OFF	OFF
	*HOTKEY1 >	LANGUAGE TEST PATTERN ASPECT RATIO BRIGHTNESS INPUT SOURCE NO FUNCTION	NO FUNCTION
	*HOTKEY2 >	LANGUAGE TEST PATTERN ASPECT RATIO BRIGHTNESS INPUT SOURCE NO FUNCTION	NO FUNCTION
	*Touch Power >	EXIT ALWAYS SIGNAL OFF	SIGNAL
	*DDC/CI >	ENABLE DISABLE	ENABLE
	SAVE >	EXIT USER1 USER2 USER3 USER4 USER5	
	LOAD >	EXIT DEFAULT USER1 USER2 USER3 USER4 USER5	
	*RECALL		

OSD Menu Settings

Level 1 (Main Menu)	Level 2	Level 3	Default
OSD Menu >	< Exit		
	OSD Language >	Norsk English Français Deutsch Italiano 日本語 簡體中文	English
	*H Position >	0 ~ 255	128
	*V Position >	0 ~ 255	128
	Transparency >	0 ~ 7	0
	*Timeout >	0 ~ 30	10
	OSD Mode >	Basic Advanced Service	Advanced
	*OSD Lock Mode >	Normal Mode Protected	Normal Mode

OSD Menu Overview

Service Settings

Level 1 (Main Menu)	Level 2	Level 3	Default
Service Settings >	< Exit		
	Video Scaler Firmware		
	Elapse Time		00000h
	Current Time		+000.0
	Test Pattern		
	*Burn In >	Enable Disable	

OSD Menu Functions

On Screen Display (OSD) Menu Functions

The following section covers all possible settings that the user can (in a certain mode) encounter or needs to adjust via easy understandable menus, text and navigation. For simpler reading the menu choice **"Exit"** has been left out of description in this chapter intentionally. Whenever **"Exit"** is available, you can exit current menu and go back to the previous one visited. When there are no more previous menus available, the OSD menu overlay will be shut off and hidden. All settings are saved real-time or when you exit any menu (including time out of menu visibility).

The number shown in the "|-----x-----" line gives the indication of the submenu level where the function is located (also reference to the table in the previous chapter). It requires the user to touch the "MENU" symbol to enter that submenu.



Please note: Available functions described may deviate slightly from actual OSD menu on your unit. This is due to different OSD software configurations and customized solutions. Shown here are factory standards.

Input Source Settings

Lets you configure Main and Secondary signal source inputs (DVI, DisplayPort, VGA or Composite video signals) as well as activate or disable the Auto Source functionality. The contents of these submenus are listed below.

- **Note: Switch time between sources is ~5 sec.**

|---2--- Input Source Settings - Main Source

The possible signal inputs are; "HDMI" (High-Definition Multimedia Interface), "VGA" (RGB/VGA), "DP" (DisplayPort) and " USB-C" (USB type-C)

- **Note: VGA input has 3 custom signal support.**

|---2--- Input Source Settings - Auto Source Select

Set to either 'Enable' or 'Disable'. Signal is automatically searched for and selected. If the Main Source signal is disconnected physically, the video controller will automatically search and select from the next item available in the list, such as; "HDMI" (High-Definition Multimedia Interface), "VGA" (RGB/VGA), "DP" (DisplayPort) and " USB-C" (USB type-C)

- **Note: If all signals are physically disconnected from the unit, the Auto Source function will loop endlessly until it detects a valid signal to display. By factory default, this setting is configured as "Enable".**
- **Switch time for next source is ~5 sec. The longest auto detection time is ~1 minute from 1st source to last source.**

OSD Menu Functions

Image Settings

Lets you configure various visual preferences for any signal. The contents of these submenu are listed below.

|---2--- Image Settings - Aspect ratio *Available in "Advanced/Service" mode

Lets you choose between 3 different aspect ratio:

- Full
- 4:3
- 16:9

• Note: Default is Full.

|---2--- Image Settings - Brightness *Available in "Advanced/Service" mode

Increase/decrease the black level saturation in real-time of the currently displayed full screen signal. The OSD Menu overlay will be unaffected. A visual slider in the OSD menu will show the current value. This value adjusts the TFT panel's brightness by controlling the voltage feed.

• Note: Value adjustable from 0 to 255. 128 is factory default.

|---2--- Image Settings - Contrast *Available in "Advanced/Service" mode

Increase/decrease the contrast in real-time of the currently displayed full screen signal. The OSD Menu overlay will be unaffected.

• Note: Value adjustable from 0 to 255. 128 is factory default.

|---2--- Image Settings - Display - H Position *Available in "Advanced/Service" mode

Settings as follows:

"H Position" = Move image within the TFT panel active area Horizontally (left/right), values from 0 to 255.

- Note: The default value is not fixed and varies depending on the input signal format.
- Note: Available for RGB/VGA mode only.

|---2--- Image Settings - Display - V Position *Available in "Advanced/Service" mode

Settings as follows:

"V.Position" = Move image within the TFT panel active area Vertically (up/down), values from 0 to 255.

- Note: The default value is not fixed and varies depending on the input signal format.
- Note: Available for RGB/VGA mode only.

OSD Menu Functions

|---2--- Image Settings - Display - Clock *Available in "Advanced/Service" mode

Adjust the horizontal frequency (clock) of the analog signal to improve visibility of the entire image. When it is adjusted, you will notice that the image will appear to be stretched and might in some situations start to flicker/scroll, at which point you must reverse the last adjustment to stop it from flickering/scrolling anymore. This function can be used for older signals that is not automatically detected by the internal display controller.

To adjust the Clock and Phase to an optimal setting it is recommended to display an image with alternating white and black lines by stepped by 1 pixels either vertically or horizontally. It is suggested to use a dedicated and external test pattern while adjusting. Values from 0 to 255.

- Note: Available for RGB/VGA mode only and 128 is factory default.

|---2--- Image Settings - Display - Phase *Available in "Advanced/Service" mode

Fine tune the data sampling position of the signal (impacts on image quality). This function will remove small transparent defects in typical characters where a portion seems to be more faint than the nearby black pixels. The faint pixels are always visible as a line from top to bottom (vertically). Note that this function is automatic and does not allow for manual values. It is suggested to use a dedicated and external test pattern while adjusting. Values from 0 to 255.

- Note: Available for RGB/VGA mode only and 128 is factory default.

Color Mode Settings

Lets you adjust the color temperature (Kelvin degrees) of the image. This applies to the Main Source signal. Lower values make the image appear warmer, while higher values will make it appear cooler. The contents of these submenus are listed below.

Illustration (does not appear in menu): The Kelvin color temperature scale (approximate and symbolic):



|---2--- Color Mode Settings - Gamma *Available in "Advanced/Service" mode

This will activate the stored gamma curve color compensation as well as the LED indicators or backlight brilliance used with ECDIS. Set to either "Calibration DP", "Calibration RGB", "Calibration DP", "Calibration USB-C" or "Calibration HDMI", where these represents the two storage locations for compensation data. When either of them are active, they will override the color temperature setting for the signal channel. Different signal channels can be set to different settings that will be saved.

This function is suitable for use with external equipment. Color temperature will be disabled.

- Note: Default is "No Calibration" with Gamma 2.2 and 140 nits.

|---2--- Color Mode Settings - Color Temperature

OSD Menu Functions

- "9300K" Cool, a blueish white.
- "8000K" Neutral, a white close to natural light
- "6500K" Warm white.

|-----3----- **Color Mode Settings - Color Temperature - User**

Allows individual adjustment of Red, Green and Blue color gains. The selected setting will be saved for each signal input respectively.

- **Note:** Value adjustable from 0 to 255. 128 is factory default.

|---2--- **Color Mode Settings - Saturation** *Available in "Advanced/Service" mode

Increase/decrease the overall video color saturation/color amount of the currently displayed full screen image (no effect on DVI/DP/VGA/HDMI/USB-C signals). Can be used if the incoming CVBS signal from older equipment (due to bad cables) appear to have a lack of strong colors or just to generally make the displayed image become more vivid. Note that this function can also make noisy color signals appear crisper/clearer if adjusted to gray scales.

- **Note:** Value adjustable from 0 to 255. 128 is factory default.

|---2--- **Color Mode Settings - Hue** *Available in "Advanced/Service" mode

Allows you to adjust/shift the main color properties of all Red, Green, Blue and Yellow (unique hues) values. This can be useful for certain Composite Video sources (no effect on DVI/DP/VGA/HDMI/USB-C signals) whose output may have shifted or seems to be "out of phase", where for instance blue seems more dominant than green, red and yellow-ish colors. By using HUE one can shift the entire color range of all components left or right in the spectrum.

- **Note:** Value adjustable from 0 to 255. 128 is factory default.

|---2--- **Color Mode Settings - Sharpness** *Available in "Advanced/Service" mode

Increase/decrease the overall image sharpness. Use it to increase the visual quality of signals from older equipment or improve electronically weak signals.

- **Note:** Value adjustable from 0 to 24. 12 is factory default.

|---2--- **Color Mode Settings - Red**

Allows individual adjustment of Red. The selected setting will be saved for each signal input respectively.

- **Note:** Value adjustable from 0 to 255. 128 is factory default.

|---2--- **Color Mode Settings - Green**

Allows individual adjustment of green. The selected setting will be saved for each signal input respectively.

- **Note:** Value adjustable from 0 to 255. 128 is factory default.

OSD Menu Functions

|---2--- Color Mode Settings - Blue

Allows individual adjustment of Blue. The selected setting will be saved for each signal input respectively.

- **Note:** Value adjustable from 0 to 255. 128 is factory default.

Communication

The unit allows for remote control (adjust brightness for example) and/or accessing internal information about the unit such as typenumber, serial number and more. To setup this feature, you first need to configure the Serial or Ethernet (USB and RS232 is already set) protocol properly to match your external equipment specifications. The contents of the submenus is listed below.

A more detailed description of the SCOM (Serial/Ethernet Communication) can be found here:

<https://www.hattelandtechnology.com/hubfs/pdfget/inb100018-6.htm>

Review also the "Pinout Assignments" chapter in this manual for additional help during preparation and/or installation of external equipment intended to communicate with.

|---2--- Communication - RS422/RS485 *Available in "Advanced/Service" mode

Choose between:

"2-wire RS-485" = Sets the internal communication to RS-485 protocol (Half duplex).

"4-wire RS-422" = Sets the internal communication to RS-422 protocol (Full duplex).

|---2--- Communication - RS Address *Available in "Advanced/Service" mode

Set the global unique channel/port ID for the unit (range 0-254).

|---2--- Communication - DHCP *Available in "Advanced/Service" mode

DHCP gives you the option to activate or deactivate DHCP. This means that if DHCP is deactivated, you can manually set the IP address. If it is activated, the device will automatically be assigned an IP address.

Note: Choose between "DISABLE" and "ENABLE"

|---2--- Communication - IP Address *Available in "Advanced/Service" mode

IP can be found Automatically or you can set the IP address manually (xxx.xxx.xxx.xxx) for Ethernet protocol by choosing "DHCP DISABLE".

Miscellaneous Settings

---2--- Miscellaneous Settings - OSD Key Outdoor *Available in "Advanced/Service" mode

To prevent accidental activation of Glass Display Control™ (GDC) touch functions, you can add an extra layer of security on how "sensitive" the touch detection operates. This applies for "MENU", "(-) Brilliance (+)" and "Power Off" functions. The OSD Key Outdoor function is especially effective if the unit is located where handheld UHF radio is commonplace or in a outside environment where

OSD Menu Functions

rain drops could potentially trigger touch button functions. Note that this setting does not apply for fullscreen sized touch screen glasses.

When OSD Key Outdoor is ON, it will continuously detect for UHF frequencies and try to block these.

Settings as follows:

"Off" = All touch symbols operates normally. Factory Default setting.
"On" = Touch symbols responds when you press and hold it for 5 seconds*

*Button presses will then operate normally until it has detected no button presses for 6 seconds (timeout period). After timeout period the OSD Key Outdoor setting will revert back to 5 seconds "press and hold" behaviour.

|---2---

Miscellaneous Settings - "Hotkey1" and "Hotkey2" *Available in "Advanced/Service"

Assign a commonly used OSD menu function to the available touch enabled Hot Keys which are located on the front of unit (user controls). The following functions are available to assign and most of them have a negative and positive counting logic. All of these functions are described before and after this segment in the manual.

Settings as follows (for both "Key 1" and "Key 2"):

"OSD Language" = Flip up/down through available languages (real-time changes).
Reference in user manual: "OSD Settings / Language"

"Aspect ratio" = Lets you choose between 3 different aspect ratio Full, 4:3 or 16:9
Reference in user manual: "Image Settings / Aspect ratio"

"Test Pattern" = Display the internal test image overriding any signal inputs. Both Hot Keys performs the same action.
Reference in user manual: "Service Settings / Test Pattern"

"Brightness" = Increase/Decrease Brightness of the TFT panel (not backlight).
Reference in user manual: "Image Settings / Brightness"

"Main Source" = Flip up/down through the available signal sources (to full screen) for Main Source.
Reference in user manual: "Input Source Settings / Main Source"

"No Function" = Nothing will be activated when user presses Hot Keys on the front. Both Hot Keys performs the same action.

- Note:Default Hot Keys are assigned to "No Function". You can assign different functions to "Key 1" and "Key 2".

OSD Menu Functions

|---2--- Miscellaneous Settings - Touch Power Enabled *Available in "Advanced/Service"

This setting allows you to enable or disable touch. You can choose whether the touch should always be enabled, enabled when there is a video signal, or disabled regardless of the situation.

Settings as follows:

- "Always " = Touch is always enabled, even if there are no image on screen. Display unit may be powered off, but require power cable connected as well as a powered on computer. Signals from touch screen will still reach the computer.
- "Signal" = Touch is enabled when any input is active as Main Input.
- "Off" = Touch power is turned off, which disables the touch functionality on the display.

• Note: Factory Default set to "Signal"

|---2--- Miscellaneous Settings - DDC/CI *Available in "Advanced/Service" mode

This setting gives you the option to enable or disable the DDC/CI function.

|---2--- Miscellaneous Settings - SAVE

Allows you to save current state of all function and values to user defined presets. The contents of the submenu is listed below.

Settings as follows:

- "User 1" = Save all OSD settings to User 1 slot.
- "User 2" = Save all OSD settings to User 2 slot.
- "User 3" = Save all OSD settings to User 3 slot.
- "User 4" = Save all OSD settings to User 4 slot.
- "User 5" = Save all OSD settings to User 5 slot.

|---2--- Miscellaneous Settings - LOAD

Allows you to load current state of all function and values to user defined presets. The contents of the submenu is listed below.

Settings as follows:

- "Default" = Load all OSD settings from Default slot.
- "User 1" = Load all OSD settings from User 1 slot.
- "User 2" = Load all OSD settings from User 2 slot.
- "User 3" = Load all OSD settings from User 3 slot.
- "User 4" = Load all OSD settings from User 4 slot.
- "User 5" = Load all OSD settings from User 5 slot.

|---2--- Miscellaneous Settings - Recall *Available in "Service" mode

Reset back to factory defaults. Will override and restore all previous modified settings.

OSD Menu Functions

OSD Menu Settings

OSD Menu Settings - OSD Language

Available OSD language to be used for all text and warnings that may appear.

Settings as follows:

"Norsk"	= Display OSD in Norwegian.
"English"	= Display OSD in English.
"Français"	= Display OSD in French.
"Deutsch"	= Display OSD in German.
"Italiano"	= Display OSD in Italian.
"日本語"	= Display OSD in Japanese.
"簡體中文"	= Display OSD in Simplified Chinese.

- **Note:** Current selected language is shown in green color. Default language is English.

OSD Menu Settings - H Position

This setting allows you to adjust the position of the OSD menu in the horizontal direction. The values that can be selected range from 0 to 255, with 128 as the default.

OSD Menu Settings - V Position

This setting allows you to adjust the position of the OSD menu in the vertical direction. The values that can be selected range from 0 to 255, with 128 as the default.

OSD Menu Settings - Transparency

Adjust the alpha blend also known as transparency of the OSD Menu overlay. It is used when important information on the display is necessary to be visible at all times.

- **Note:** Level adjustable from 0 to 7. 0 where 0 factory default (no transparency/solid background color).

OSD Menu Settings - Timeout

Adjust the timeout in seconds that the OSD menu overlay is automatically exited and hidden from view including locking mode (see OSD Lock Mode/Advanced Mode on next page). This timeout is counted from last activity (navigation or adjusting parameters). The value is adjustable from 0 to 30 seconds.

- **Note:** Default timeout value is 10 seconds.

OSD Menu Settings - OSD Mode

Configuring the OSD Menu access based on most common functions to service/troubleshooting.

Settings as follows:

"Basic"	= A few functions is not visible/available in this state. For most uses this is the preferred setting and are safe for the display functionality and continuous trusted operation on the unit.
---------	--

OSD Menu Functions

"Advanced" = All functions and parameters is visible/available in this state. Some of the settings adjusted could impact on display functionality and image quality. Only experienced and qualified personnel should access and change parameters when in this mode. Also, more technical details about signals, frequency will be available.

"Service" = Only applicable for authorized service personnell. Key code is available from Hatteland Technology service network / Technical Support.

- **Note:** Learn how to navigate and enter the correct code, by reading the "OSD Keycode / OSD Lock Mode" introduction section in the previous chapter.
- **Note:** When requesting "Advanced" mode from "Basic" mode, the user is required to enter a key code. This code is factory preset to "362". You can enter the code by using navigation and "MENU" to confirm. After a successful entering of the key code, the OSD menu will always be in this state during powered on. After a power off and on to the unit, the OSD Mode will be still be in "Advanced" mode.

|---2---

OSD Menu Settings - OSD Lock Mode ***Available in "Advanced/Service" mode only**

To prevent accidental or unwanted user intervention, you can set the behaviour of how the OSD menu is accessible by the user including adjusting brightness via the "(-) Brilliance (+)" symbols. Normally by factory default accessible by pressing the "MENU" function on the front (user controls).

Settings as follows:

"Normal Mode" = Default accessible pop-up by touching the "MENU" symbol.
For Non-ECDIS Compliant usage.

"Protect" = To comply with ECDIS regulations, a key code (321) must be entered before the OSD menu appears when the "MENU" symbol on the front glass is touched. When activated, the process requires holding the "MENU" symbol for 5 seconds, after which the key code requester appears. Only the "MENU" symbol triggers the password request, ignoring touches on other symbols. Upon successful key code entry, the OSD menu becomes accessible, all owing "x" seconds to adjust brilliance and power functions before all functions deactivate and the system returns to "Advanced Mode." The "x" value corresponds to the OSD Timeout setting.

- **Note:** Learn how to navigate and enter the correct code, by reading the "OSD Keycode / OSD Lock Mode" introduction section earlier in this chapter.

OSD Menu Functions

Service Settings

Will show various technical and unit related information, such as; Firmware versions, Elapsed Time, current time and activation for the internal Test Pattern image useful for trouble-shooting. Some of these functions are static information while others are accessible. Whenever you are in contact with helpdesk or service, they might require you to read back some of these values in order to precisely pinpoint any problem/question you should have with the unit or its functionality.

Information blocks as follows:

"Video Scaler Firmware"	= Displays the firmware version of the internal videocontroller. Example: "VIC21VF-000STD-001"
"uC Firmware"	= Displays the firmware version of the touch enabled buttons. Example: "VIC21VF-000STD-001"
"Elapsed Time"	= Shows the time elapsed in hours since first-time power on. Example: "180"
"Current Time"	= Shows the internal temperature measured by onchip sensor. Example: "+027.0 C", in Celcius Degrees.

|---2---

Service Settings - Burn in

Used to Warm up the panel with full-screen solid color. For internal testing purposes only. Please contact your nearest Hatteland Technology or Service Partner before using this setting.

Serial/Ethernet/USB Communication (SCOM) Interface

Introduction

This document defines the electrical interface, serial data format, and communication protocols of the Serial Communication Control Interface (SCOM). The purpose of this interface is to enable a computer application to control one or more units. Unit refer to display product. Interface configuration done within OSD Menu.

Serial / USB Interface Configuration

The serial / USB interface can have different configurations defined as follows:

RS-232	One computer controls one unit, no individual address
USB	One computer controls one unit, no individual address
4-wire RS-485/RS-422	One computer controls units, each with individual address.
2-wire RS-485	One computer controls units, each with individual address.

Each unit will be assigned with an address value before it is connected to a shared network. The user application (PC) can send the message to the specific unit by marking the message with corresponding address number. The unit which has the matching address will respond immediately, while the others keep silent.

Broadcast commands will be processed by all linked units simultaneously once the last byte of the message is received. In order to avoid conflict on bus, each unit should respond back at different times. As the units are working independently, they can hardly know how many units are linked in the same bus. In this case, the interval between receiving message and responding back should be calculated in the base of their own address. The lowest addressed unit will respond first.

To calculate the address based interval, there is a formula to calculate the interval (Te):

$T_e = (T_r + L_r) * N$, where
Lr = length of the ACK/NAK message response
Tr = Response time
N = the total number of monitors

Response time Tr is a fixed value which are calculated to make sure there is no conflict on the bus. Principally, Tr is equivalent to 2.5 byte periods after the last byte of a command message is received. However, due to the difference in microcontroller clock, all the units may not finish the message receive at the same timing point. So the Tr should be calculated based on the jitter changes.

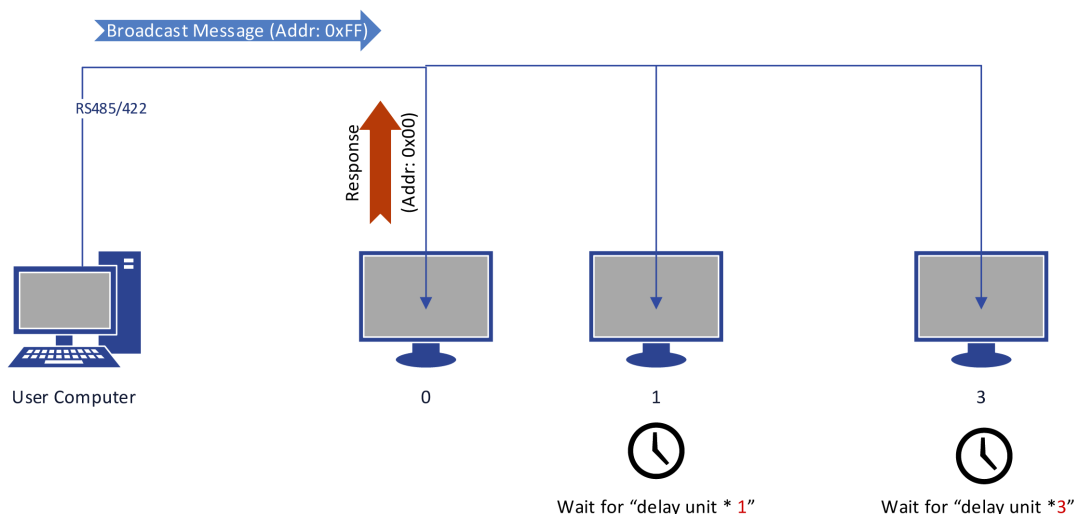

Illustration: Broadcast Message: Timing 1

Serial/Ethernet/USB Communication (SCOM) Interface

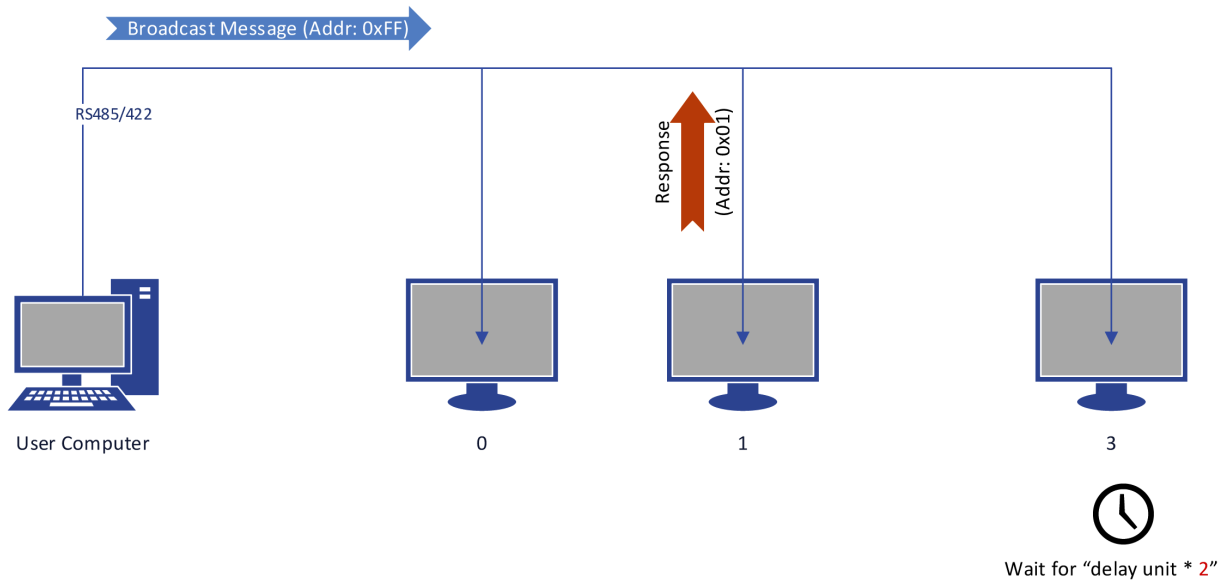

Illustration: Broadcast Message: Timing 2

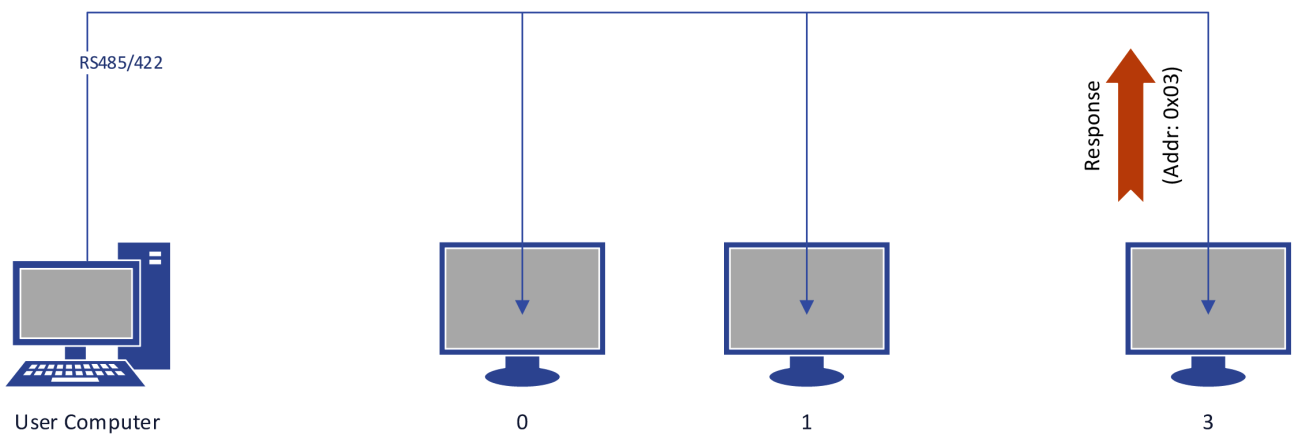

Illustration: Broadcast Message: Timing 3

User computer is linked with three units via the RS485 bus. These three units are assigned in address: 0, 1, 3. At the beginning, User computer broadcast a message to all connected units. Assuming all of them finish receiving at the same time, then the address '0' unit will respond with no latency. The other two units with higher address, stay silent until the calculated delay expires.

For the user computer, there is also a formula to calculate the interval between broadcast message. After the previous message was sent, the next message should not be issued until:

$$T_c = T_{e_max} + T_g, \text{ where}$$

$$T_{e_max} = \text{Max}(T_e)$$

$$T_g = \text{the receiving time of 5 bytes.}$$

For example, a test computer connects 8 units on bus, the interval between broadcast messages is calculated as:

$$T_c = (T_r + L_r) * 8 + T_g.$$

Serial/Ethernet/USB Communication (SCOM) Interface

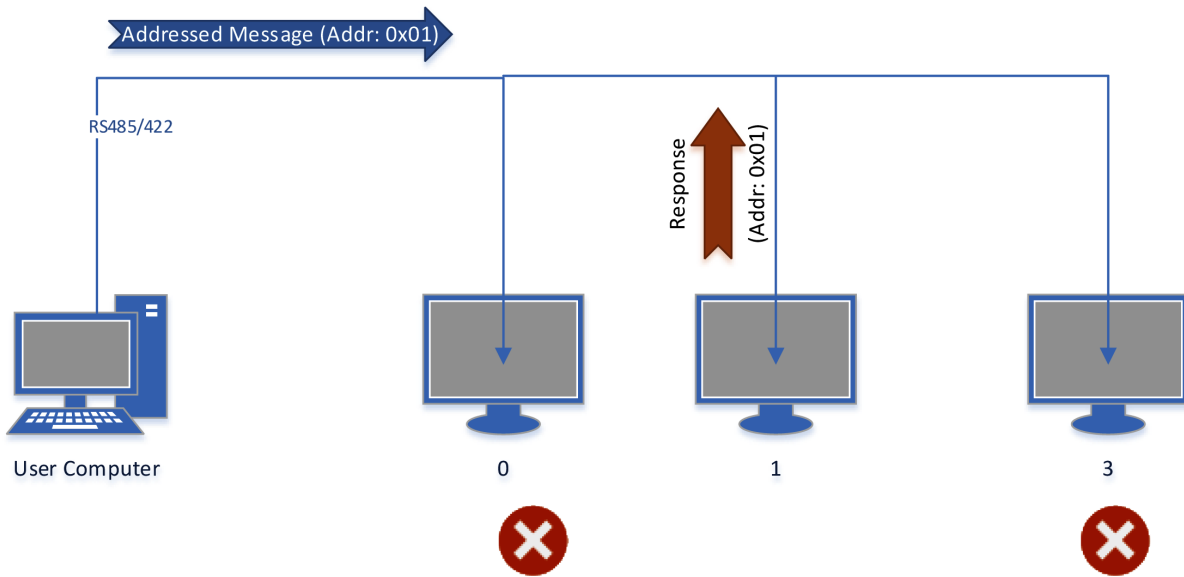

Illustration: Addressed Message

In the scenario that user computer sends out the message to specific address, the unit which owns the matching address will respond immediately, while the other keep silent.

Ethernet Interface Configuration

The Ethernet/LAN/Network interface are selected by the OSD menu. The configuration is defined as follows:

Ethernet	One computer controls units via Automatic IP or Fixed IP through port 10001. IP address for the computer must be on the same subnet as the internal set IP of the unit. The local software firewall on computer, router or network system must accept communication in/out on port 10001 (open port).
----------	---

The SCOM message contained in TCP is the same as the one used in RS232/485/422.

Check the section later in this manual "C# / Pseudo Ethernet/TCP Code example".

Cables

Serial Mode: A cable with an overall shield terminated at the back shell should be used.

Ethernet Mode: A CAT-5, CAT-6 cable capable of 10/100/1000Mbps bandwidth transmissions.

USB Mode: A USB Type A-A (male-male) cable, less than 5meters is recommended.

Electrical Interface

Electrical signals shall conform to RS-485, RS-422, RS-232, USB or Ethernet standards. Only Receive Data, Transmit Data, and Signal Ground are used. The same conditions apply for both Serial mode 4-wire (Full Duplex) and 2-wire (Half Duplex), and will just be referred to as RS-485 in this document. Hardware handshake is only supported by loopback handshake for RS-232.

Serial/Ethernet/USB Communication (SCOM) Interface

- Compatible connectors (as listed on datasheets):

- SCOM RS-422/485 : Terminal Block Connector 3.81, non-isolated
- SCOM RS-232 : D-SUB 9P (female), non-isolated
- SCOM Ethernet : RJ45 (female)
- SCOM USB : USB-C (Type C, female)

Multiple access:

NXP Firmware : VIC21VF-000STD-001

Video Scaler Firmware:

- Series X G2 MMD models: VIC21VF-000STD-001

Serial/Ethernet/USB Communication (SCOM) Interface

For Pin Out assignments, please review the following diagrams that covers all units and connector types: Connectors illustrated here are either standard by factory default or may be available (through factory customization). Note that some combinations may not be possible due to space restrictions. List also valid for customized models. All pin out assignments are seen from users Point of View (POV) while looking straight at the connector. Please review the dedicated datasheet or technical drawings for your actual unit to identify and determine the presence of desired connector.

10-pin RS-422 / RS-485 Module w/Buzzer



All pinout assignments are seen from users Point of View (POV) while looking straight at the connector.

RS-422/RS-485 SCOM + Buzzer (Internal Buzzer can be controlled externally).

Pin 1,3,5,7 = RS-485 Full Duplex (4-wire)
Pin 5,7 = RS-485 Half Duplex (2-wire)

Buzzer - External Drive Logic:

- Able to supply 12VDC+5%@100mA
- Short circuit protected at <500mA
- <50VDC from ground of Display unit (Our input is isolated, this is layout limitation)
- Our input is classified as signal input, not power.

Notes:

Unit may have several physical connectors available for Buzzer control. Please only use RS-232 or RS-485 pins to control Buzzer, not both at the same time.

Series X (G1 - Generation 1):

- External drive logic can drive the buzzer even when the Display Unit is off.

Series X (G2 - Generation 2) / MVD Series:

- Display Unit needs external power connected to turn buzzer on. (Any logic power state).

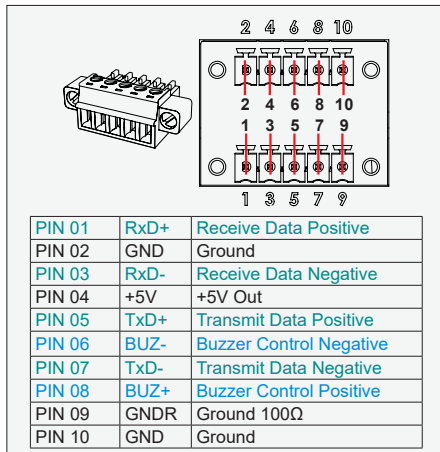

10-pin RS-422 / RS-485 Module w/Buzzer



All pinout assignments are seen from users Point of View (POV) while looking straight at the connector.

Suggested "Buzzer" Control Logic inside Computer/System. Display Unit needs external power connected to turn buzzer on. (Any logic power state).

To ensure that EMC requirements are met, we recommend that the cable is screened and screen is terminated/grounded at both ends with as short as possible pig tail. For Military/Naval use: +12V line from customer system should be low pass filter or else the power ripple may cause radiated emission to fail. Use a cable that contains at least 2 wires (not 2 single wires). Test connection (beep) with Voltage Meter. Wires may be combined if using RS-422/485 COM as well.

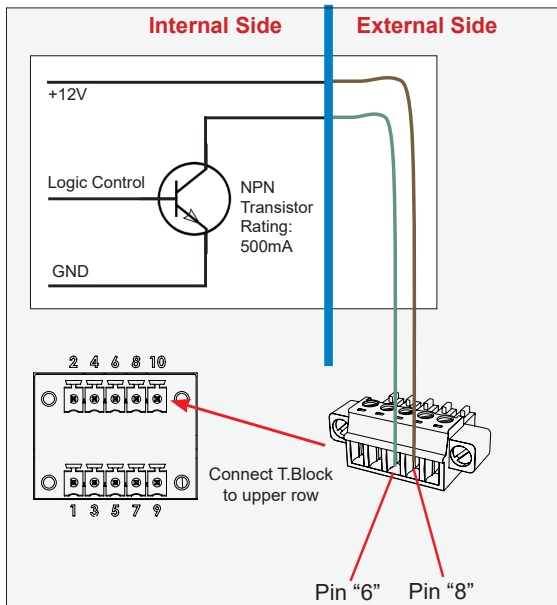

8-pin RJ45 10/100/1000Mbps LAN/Ethernet



All pinout assignments are seen from users Point of View (POV) while looking straight at the connector.

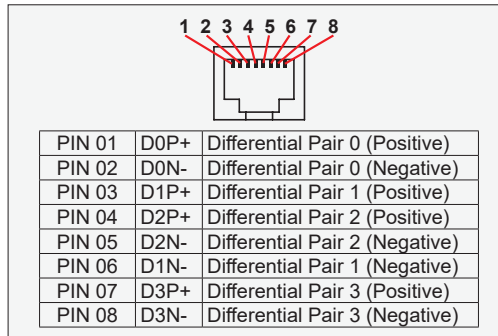

9-pin Serial COM RS-232+Buzzer non-isolated, DSUB Male



All pinout assignments are seen from users Point of View (POV) while looking straight at the connector.
RS232-Wake On Ring is not enabled.

Buzzer - External Drive Logic:

- Able to supply 12VDC+5%@100mA
- Short circuit protected at <500mA
- <50VDC from ground of Display unit (Our input is isolated, this is layout limitation)
- Our input is classified as signal input, not power.

Series X (G1 - Generation 1):

- External drive logic can drive the buzzer even when the Display Unit is off.

Series X (G2 - Generation 2) / MVD Series:

- Display Unit needs external power connected to turn buzzer on. (Any logic power state).

Notes:

Unit may have several physical connectors available for Buzzer control. Please only use RS-232 or RS-485 pins to control Buzzer, not both at the same time.

Note: Requires soldering and assembly. It is expected that the technician has experience in electronics, soldering and assembling cables and connectors. Use a cable that contains at least 2 wires (not 2 single wires). Heat Shrink Tubes must be applied to soldered wirepins. Test connection (beep) with Voltage Meter. Wires may be combined if using RS-232 COM as well.

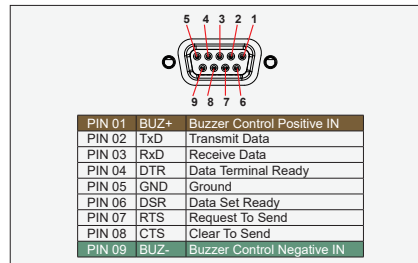

All pinout assignments are seen from users Point of View (POV) while looking straight at the connector.

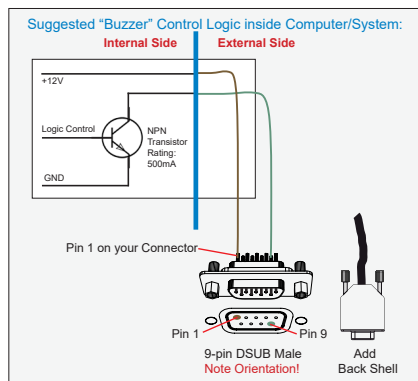

24-pin USB-C TYPE A + USB2.0 Female



All pinout assignments are seen from users Point of View (POV) while looking straight at the connector.

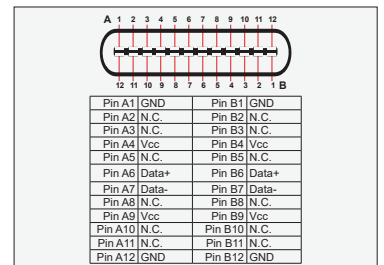

Serial/Ethernet/USB Communication (SCOM) Interface

SCOM Introduction

The SCOM commands specified in this document are of the same structure as older versions of Hatteland Technology SCOM commands for other products. This format will be explained in the following sections.

Data Rates

The unit is configured to transmit and receive data at 9600 bits/second (Serial mode) or via standard Ethernet 10/100/1000Mbps connection through port 10001.

Data Format Serial Mode

Data shall be transmitted with no parity, 8 data bits, one start bit and one stop bit. XON/XOFF flow control should be switched off/disabled.

Message Format

The basic message format shall be as follows:

Byte #	0	1	2	3	4	5	6	7	8 or 7+DATA=END
	ATTN	ADDR	CMD	CMD	CMD	LEN	IHCHK	DATA	IDCHK

The minimum message size is 7 bytes (0x07). The maximum message size is 82 bytes (0x52), consistent with the EN61162-1 standard. Colors will be used throughout this manual to indicate byte positions. Every byte sent are viewed in this document as HEX values and are based on standard characters in the ASCII table (0 to 255) to send or receive messages in a human readable input/output. No further decoding or decrypting functionality is needed or required. Every command sent and received are always ended with a 0x00 (null byte terminator).

Byte 0 is sent first then the rest of the bytes follow, there is no handshake during this transmissions. Bytes are sent as fast as possible.

ATTN

Attention (ATTN)

This single byte is used to identify a start of message. 3 values are possible:

ATTN	Description
0x07	Command, also known as ASCII BELL
0x06	Acknowledge, also known as ASCII ACK
0x15	Negative Acknowledge, also known as ASCII NAK

A device sends a command using the 0x07 Attention Code. The unit will respond to the command with either an ACK if the command completed successfully, or a NAK if the command failed. The unit also replies with a NAK if the command was not understood, invalid or unsupported. If a command description doesn't state differently then with NAK attention code the unit will return received data. The unit will ignore any message that doesn't start with Command attention code.

NOTE: A complete HEX, ASCII, BIN and Character table overview are available in the APPENDIX chapter.

Serial/Ethernet/USB Communication (SCOM) Interface

ADDR

Address (ADDR)

This single byte is used to specify a particular unit to receive a Command and to identify the unit responding (ACK or NAK) to a Command. All units will support the broadcast address. The factory default address is 0x00, while in this manual illustrated throughout as 0xFF. Only in use when in RS-485/RS-422 mode. Otherwise 0xFF shall be used.

The Address field shall have the following values:

ADDR	Description
0xFF	Broadcast - Addressed to all units
0x00 to 0xFE	Address of a specific unit, 0 to 254 (max 255 units)

CMD

Message Commands and Queries (CMD) Contents

The command can be one of the following values and consists always of 3 bytes in positions 2,3,4:
See page 3

LEN

Data Length (LEN)

This single byte defines the length of DATA in the message in bytes. The maximum value for this field is 74 bytes (0x4A in HEX). The minimum value is 0 bytes (0x00 in HEX).

IHCHK

Inverse Header Checksum (IHCHK)

This single byte is a simple 8-bit checksum of the header data, message bytes 0 to 5 on which a bit-wise inversion has been performed. The checksum will be initialised to 0. The 8-bit sum (without carry) of bytes 0, 1, 2, 3, 4, 5 and 6 will be 0xFF (255 in value). If the unit receives a message with an incorrect checksum, the unit will reply with the attention code set to NAK and no data field.

DATA

Data Field (DATA)

The bytes is the DATA field which will only be transmitted if LEN is greater than 0. This field depends on the CMD transmitted.

IDCHK

Inverse Data Checksum (IDCHK)

This single byte will only be transmitted if LEN is greater than 0. This is a simple 8-bit checksum of the data field, message bytes 7 to 7+(LEN-1) on which a bit-wise inversion has been performed. The checksum will be initialised to 0. The 8-bit sum (without carry) of bytes 7 through 7+LEN inclusive will be 0xFF. The receiver will reply to any message that the checksum has failed with the attention code set to NAK. Basically this byte is located at the very end of a received stream.

NOTE: A complete HEX, ASCII, BIN and Character table overview are available in the APPENDIX chapter.

Serial/Ethernet/USB Communication (SCOM) Interface

Message Commands and Queries (CMD) Contents

Byte 2	Byte 3	Byte 4	ASCII	Description	I/O	Non-Volatile / Volatile
0x42	0x52	0x49	BRI	Minimum Brightness	R/W	NV
0x42	0x52	0x4D	BRM	Maximum Brightness	R/W	NV
0x42	0x52	0x54	BRT	Brightness Control	R/W	V
0x42	0x52	0x4C	BRL	GDC LED Brightness Control	R/W	NV
0x42	0x52	0x55	BRU	User Brightness Control	R/W	NV
0x47	0x4D	0x42	GMB	GDC minimum brightness	R/W	NV
0x47	0x42	0x46	GBF	Keypad Brightness auto follow	R/W	NV
0x4C	0x49	0x53	LIS	Read Ambient Light Sensor	R	
0x4F	0x44	0x4D	ODM	Outdoor Mode	R/W	NV
0x52	0x45	0x43	REC	Recall GDC	W	
0x50	0x4F	0x54	POT	Potential Meter Control	R/W	NV
0x46	0x48	0x41	FHA	Feature header configuration (remap functions in POT command)	R/W	NV
0x42	0x5A	0x5A	BZZ	Buzzer Control On/OFF	R/W	V
0x53	0x57	0x49	SWI	Read NXP Firmware Version	R	
0x53	0x57	0x56	SWV	Read Video Scaler Firmware Version	R	
0x54	0x59	0x50	TYP	Read Type Number	R	
0x53	0x4E	0x42	SNB	Read Serial Number	R	
0x53	0x43	0x49	SCI	Write Customer Service ID	W	NV
0x43	0x53	0x49	CSI	Read Customer Service ID	R	
0x45	0x54	0x43	ETC	Elapsed Time Counter Query System	R	
0x4D	0x41	0x4E	MAN	Read Manufacture ID Code	R	
0x54	0x4D	0x50	TMP	Read Temperature Sensor	R	
0x56	0x45	0x52	VER	Inquiry specific Type Number	R	
0x46	0x57	0x56	FWV	Inquiry Firmware Versions	R	
0x43	0x42	0x52	CBR	COM1&2 Port Baudrate	R/W	NV
0x42	0x41	0x4B	BAK	Turn on/off acknowledge on broadcast command	R/W	NV
0x44	0x4C	0x4E	DLN	Download ECDIS Package	R	
0x44	0x4C	0x3F	DL?	Request Number of available ECDIS Pack	R	
0x43	0x41	0x4C	CAL	ECDIS calibrated brightness inquiry	R	
0x52	0x43	0x46	RCF	Recall Factory default	W	
0x50	0x57	0x52	PWR	Power On/Off/Sleep unit	W	
0x44	0x53	0x54	DST	Display State	W	
0x56	0x55	0x52	VUR	Read User Configuration from Video Scaler	R	
0x56	0x55	0x53	VUS	Write User Configuration to Video Scaler	W	
0x07	0xFF	0x4D	MOD	Operation Mode Selection	R/W	
0x4D	0x43	0x43	MCC	OSD Menu Control Commands + Commands List Table*	R/W	

I/O = R=Read, W=Write.

Volatile = V=The variable values controlled by these commands are cleared at power restart).

Non-Volatile = NV=The variable values controlled by these commands are stored even after power restart.

Page # = Page number in this manual where command is detailed.

*MCC

OSD Menu Control Commands. "MCC" command also features a Query "?" mode, "R" or "r" reset mode to factory default, increase +1 from current value "+" and decrease -1 from current value "-". Details and usage of these commands are available later in this manual.

Serial/Ethernet/USB Communication (SCOM) Interface

Serial/Ethernet/USB Communication (SCOM) Interface

SCOM Section: Brightness

In SCOM protocol, there are five brightness related commands, which define the backlight/LED brightness value and their adjustable range.

LCD Brightness : Full range of LCD backlight.
System Brightness : Full range of system level brightness.
User Brightness : Variation range of User level.

- BRI: Minimum backlight brightness.
- BRM: Maximum backlight brightness.
- BRT: Backlight brightness.
- BRU: User backlight brightness.

BRI and **BRM** value define the min & max boundary of the visual backlight brightness. **BRT** gives the global backlight brightness value. However, **BRT** should be the value between **BRI** and **BRM**.

BRU is the user backlight control which presents the user controlled brightness value. This value is linked with potentiometer (when POT is valid). The adjustable scale for BRU value is 0 ~ 255. The corresponding PWM steps behind BRU, is framed by BRI and BRT. The visual variation range for BRU is from BRI to BRT. The BRU steps are scaled down into 255 by the value between BRI and BRT.

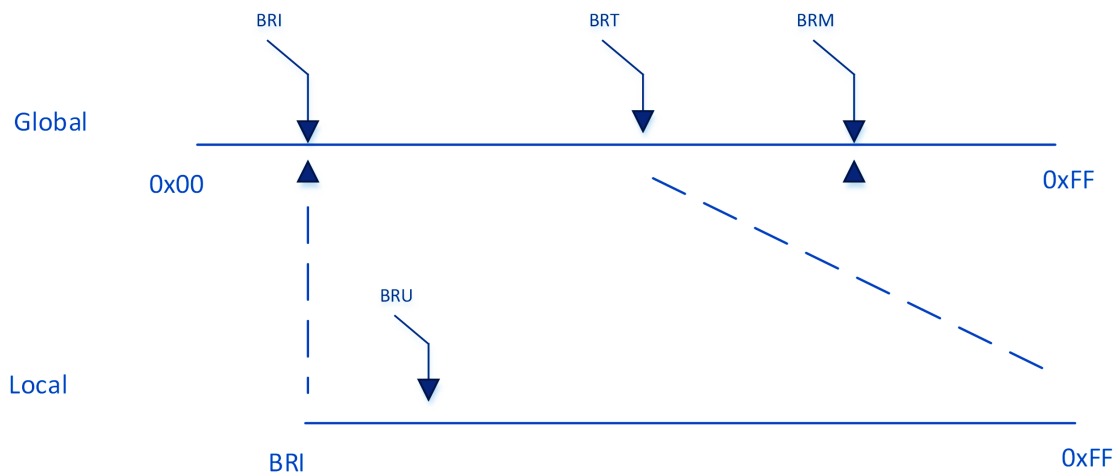

Illustration: Brightness Logic

Serial/Ethernet/USB Communication (SCOM) Interface

"BRI" - Minimum Backlight Brightness

The command is used to set the minimum brightness of backlight. It defines the lower bound of the visual brightness range. For example, if we set BRI to 10%, the minimum achievable brightness is 10% in PWM step curve.

Byte #	0	1	2	3	4	5	6	7	8
	0x07	0xFF	0x42	0x52	0x49	0x01	IHCHK	Min Brightness	IDCHK

Minimum Brightness: A value describing the minimum backlight brightness.

Range: [0x00-0xFF]

0x00: is off.

0xFF: is max brightness.

After unit reset the value is set to: last stored value.

After microcontroller reset the value is set to: last stored value. (0xFF if no stored value).

Write:

Sets the minimum backlight brightness. The brightness value shall be sent as 1 byte in the DATA field.

Example:

Set 60% BRI:

0x07	0xFF	0x42	0x52	0x49	0x01	0x1B	0x99	0x66
------	------	------	------	------	------	------	------	------

ACK reply from unit:

0x06	0xFF	0x42	0x52	0x49	0x01	0x1C	0x99	0x66
------	------	------	------	------	------	------	------	------

Read:

Read the minimum backlight brightness. The length of data shall be zero.

Example:

Get BRI:

0x07	0xFF	0x42	0x52	0x49	0x00	0x1C
------	------	------	------	------	------	------

ACK reply from unit:

0x06	0xFF	0x42	0x52	0x49	0x01	0x1C	0x99	0x66
------	------	------	------	------	------	------	------	------

Serial/Ethernet/USB Communication (SCOM) Interface

"BRM" - Maximum Backlight Brightness

The command is used to set the maximum brightness of backlight. It defines the upper bound of the visual brightness range. For example, if we set BRM to 90%, the maximum achievable brightness is 90% in PWM step curve.

Byte #	0	1	2	3	4	5	6	7	8
	0x07	0xFF	0x42	0x52	0x4D	0x01	IHCHK	Max Brightness	IDCHK

Maximum Brightness: A value describing the maximum backlight brightness.

Range: [0x00-0xFF]

0x00: is off.

0xFF: is max brightness.

After unit reset the value is set to: last stored value.

After microcontroller reset the value is set to: last stored value. (0xFF if no stored value).

Write:

Sets the maximum backlight brightness. The brightness value shall be sent as 1 byte in the DATA field.

Example:

Set 60% BRM:

0x07	0xFF	0x42	0x52	0x4D	0x01	0x17	0x99	0x66
------	------	------	------	------	------	------	------	------

ACK reply from unit:

0x06	0xFF	0x42	0x52	0x4D	0x01	0x18	0x99	0x66
------	------	------	------	------	------	------	------	------

Read:

Read the minimum backlight brightness. The length of data shall be zero.

Example:

Get BRM:

0x07	0xFF	0x42	0x52	0x4D	0x00	0x18
------	------	------	------	------	------	------

ACK reply from unit:

0x06	0xFF	0x42	0x52	0x4D	0x01	0x18	0x99	0x66
------	------	------	------	------	------	------	------	------

Serial/Ethernet/USB Communication (SCOM) Interface

"BRT" - Brightness Control

This command controls the display backlight brightness setting. If BRT is 100%, the user can adjust the user brightness (BRU) from 0-100%. If the BRT is set to 60%, the visual brightness is set to 60%. The user can adjust the user brightness (BRU) from 0-100% within the 60% set by BRT. If the user sets the user Brightness to half (BRU=50%), the visual brightness will be 30% (half of 60%). If BRT is set back to 100%, the visual brightness will be 50% (half of 100%).

Byte #	0	1	2	3	4	5	6	7	8
	0x07	0xFF	0x42	0x52	0x54	0x01	IHCHK	BRT	IDCHK

BRT: A value describing the brightness.

This command can only be set using SCOM and can not be adjusted directly by press of a button etc.

Range: [0x00-0xFF]

0x00: is off.

0xFF: is max brightness.

After unit reset the value is set to: Load BRT value from factory configuration file.

After microcontroller reset the value is set to: Load BRT value from factory configuration file.

Write:

The brightness value shall be sent as one byte in the DATA field. Intermediate values will control brightness over the range from minimum to maximum luminance.

Example:

Set 60% BRT:

0x07	0xFF	0x42	0x52	0x54	0x01	0x10	0x99	0x66
------	------	------	------	------	------	------	------	------

ACK reply from unit:

0x06	0xFF	0x42	0x52	0x54	0x01	0x11	0x99	0x66
------	------	------	------	------	------	------	------	------

Read:

Get the BRT variable. To trigger a BRT read command, the length of the DATA field must be zero. The DATA field in the microcontroller reply will indicate the current brightness control setting.

Example:

GET BRT value:

0x07	0xFF	0x42	0x52	0x54	0x00	0x10
------	------	------	------	------	------	------

ACK reply from unit:

0x06	0xFF	0x42	0x52	0x54	0x01	0x11	0x99	0x66
------	------	------	------	------	------	------	------	------

Serial/Ethernet/USB Communication (SCOM) Interface

"BRL" - GDC LED Brightness Control

The command is used to set the keypad's LED brightness manually. This can only control the Brightness LED if the GBF command is set to not follow backlight.

Byte #	0	1	2	3	4	5	6	7	8
	0x07	0xFF	0x42	0x52	0x4C	0x01	IHCHK	Brightness LED	IDCHK

Brightness LED: A value describing the front button LED brightness.

Range: [0x00-0xFF]

0x00: is off.

0xFF: is max brightness.

After unit reset the value is set to: last stored value.

After microcontroller reset the value is set to: last stored value. (0xFF if no stored value)

Write:

Sets the button LED brightness. The brightness value shall be sent as 1 byte in the DATA field.

Example:

Set 60% BRL:

0x07	0xFF	0x42	0x52	0x4C	0x01	0x18	0x99	0x66
------	------	------	------	------	------	------	------	------

ACK reply from unit:

0x06	0xFF	0x42	0x52	0x4C	0x01	0x19	0x99	0x66
------	------	------	------	------	------	------	------	------

Read:

Gets the button LED brightness. The length of data shall be zero.

Example:

Get BRL:

0x07	0xFF	0x42	0x52	0x4C	0x00	0x19
------	------	------	------	------	------	------

ACK reply from unit:

0x06	0xFF	0x42	0x52	0x4C	0x01	0x19	0x99	0x66
------	------	------	------	------	------	------	------	------

Serial/Ethernet/USB Communication (SCOM) Interface

"BRU" - User Brightness Control

This command controls the user brightness control (BRU). If BRT is 100%, the user can adjust the user brightness (BRU) from 0-100%. If the BRT is set to 60%, the visual brightness is set to 60%. The user can adjust the user brightness (BRU) from 0-100% within the 60% set by BRT. If the user sets the user brightness to half (BRU=50%), the visual brightness will be 30% (half of 60%). If BRT is set back to 100%, the visual brightness will be 50% (half of 100%).

Note: BRU read is also open to VS for user brightness inquiry.

Byte #	0	1	2	3	4	5	6	7	8
	0x07	0xFF	0x42	0x52	0x55	0x01	IHCHK	BRU	IDCHK

BRU: A value describing the brightness. This command can be directly adjusted using buttons.

Range: [0x00-0xFF]

0x00: is off.

0xFF: is max brightness.

After unit reset the value is set to: last stored value.

After microcontroller reset the value is set to: last stored value. (0xFF if no stored value)

Write:

Set the BRU variable. The brightness value shall be sent as 1 byte in the DATA field.

Example:

Set 60% Brightness:

0x07	0xFF	0x42	0x52	0x55	0x01	0x0F	0x99	0x66
------	------	------	------	------	------	------	------	------

ACK reply from unit:

0x06	0xFF	0x42	0x52	0x55	0x01	0x0A	0x99	0x66
------	------	------	------	------	------	------	------	------

Read:

Get the BRU valuable. To trigger a BRU read command, the length of the DATA field must be zero. The DATA field in the microcontroller reply will indicate the current brightness control setting.

Example:

Get BRU value:

0x07	0xFF	0x42	0x52	0x55	0x00	0x10
------	------	------	------	------	------	------

ACK reply from unit:

0x06	0xFF	0x42	0x52	0x55	0x01	0x0A	0x99	0x66
------	------	------	------	------	------	------	------	------

Serial/Ethernet/USB Communication (SCOM) Interface

SCOM Section: Glass Display Control™ (GDC)

Commands related to configure and control the GDC behaviour.

"GMB" - Buttons Minimum Brightness

This command controls the minimum brightness level of the button LEDs of keypad and GDC system. The BRL level can never be lower than this limit no matter which "GBF mode" it is in.

Byte #	0	1	2	3	4	5	6	7	8
	0x07	0xFF	0x47	0x4D	0x42	0x01	IHCHK	Buttons Minimum Brightness	IDCHK

Buttons Minimum Brightness: A value describing the minimum allowed LED brightness level.

Range: [0x00-0xFF]

0x00: is "No minimum limit".

0xFF: is "Buttons will always be at max brightness".

After unit reset the value is set to: last stored value.

After microcontroller reset the value is set to: last stored value. (0x00 if no stored value)

Write:

This command will set the minimum brightness level of the button LEDs. The brightness value shall be sent as 1 byte in the DATA field. If the current level of the button brightness (BRL) is lower than the new GMB value, BRL level must be raised to the GMB level.

Example:

Set GMB 0x01:

0x07	0xFF	0x47	0x4D	0x42	0x01	0x22	0x01	0xFE
------	------	------	------	------	------	------	------	------

ACK reply from unit:

0x06	0xFF	0x47	0x4D	0x42	0x01	0x23	0x01	0xFE
------	------	------	------	------	------	------	------	------

Read:

If the current BRL level is smaller than the GMB level, this command will return the GMB level. If the current BRL level is bigger than the GMB level, this command will return the BRL level. The length of DATA shall be zero.

Example:

Get GMB:

0x07	0xFF	0x47	0x4D	0x42	0x00	0x22
------	------	------	------	------	------	------

ACK reply from unit:

0x06	0xFF	0x47	0x47	0x4D	0x42	0x01	0x23	0x99*	0x66
------	------	------	------	------	------	------	------	-------	------

*In this example, BRL was bigger than GMB level and thus BRL was returned.

Serial/Ethernet/USB Communication (SCOM) Interface

"GBF" - Keypad Brightness auto follow

This command controls if the keypad brightness level will follow the LCD backlight brightness, follow the brightness sensor, or if the keypad brightness shall be manually set by BRL command. If the GBF command is set to follow the LCD backlight brightness, or the light sensor brightness, the result is scaled by the BRL.

Byte #	0	1	2	3	4	5	6	7	8
	0x07	0xFF	0x47	0x42	0x46	0x01	IHCHK	Follow LCD	IDCHK

Follow LCD: A value describing if the Keypad LED brightness will follow the LCD backlight level, brightness sensor or need to be manually updated through BRL command.

Range: Valid levels in table:

0x00	Keypad brightness will be set manually.
0xAA	Keypad brightness will follow brightness sensor.
0xFF	Keypad brightness will follow LCD backlight level.

After unit reset the value is set to: last stored value.

After microcontroller reset the value is set to: last stored value. (0xFF if no stored value)

Write:

Set value of GBF. The Length of DATA is 1.

Example:

GBF set to follow backlight:

0x07	0xFF	0x47	0x42	0x46	0x01	0x0E	0xFF	0x00
------	------	------	------	------	------	------	------	------

ACK reply from unit:

0x06	0xFF	0x47	0x42	0x46	0x01	0x0F	0xFF	0x00
------	------	------	------	------	------	------	------	------

Read:

To trigger the Read GBF command, the length of DATA must be zero.

Example:

GBF Read Command:

0x07	0xFF	0x47	0x42	0x46	0x00	0x0E
------	------	------	------	------	------	------

ACK reply from unit:

0x06	0xFF	0x47	0x42	0x46	0x01	0x0F	0xFF	0x00	0x66
------	------	------	------	------	------	------	------	------	------

*In this example, BRL was bigger than GMB level and thus BRL was returned.

The following 2 pages are notes for the **GBF** command.

Notes for the "GBF" command

1: Auto Follow LCD backlight level

- Use System brightness (BRI, BRM, BRT) and User Brightness (BRU) to calculate the LCD Brightness Step.
- Find the position in LCD brightness PWM curve and generate proper PWM to LCD.
- Convert the position of LCD PWM curve to Keypad PWM Curve based on gamma.
- Use the converted value to generate proper PWM to keypad.
- GMB defines the low-end saturated value of keypad brightness. BRL defines the high-end saturated value of keypad brightness.

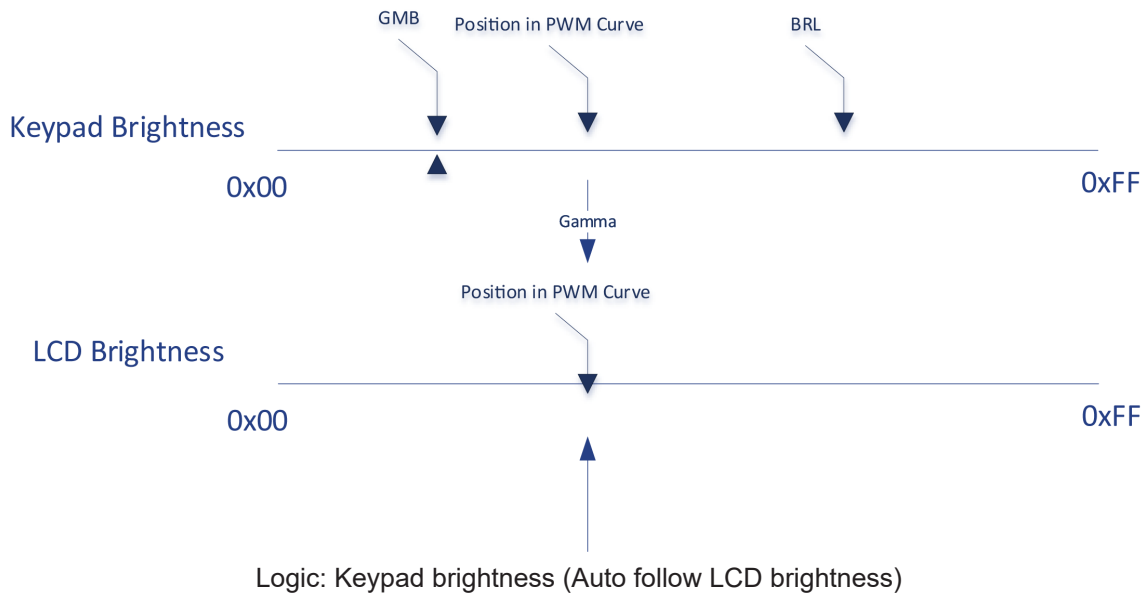

2: BRL Only

- Use System brightness (BRI, BRM, BRT) and User Brightness (BRU) to calculate the LCD Brightness Step.
- Find the position in LCD brightness PWM curve and generate proper PWM to LCD.
- Keypad brightness is independent with LCD brightness.
- Use the BRL value to generate proper PWM to keypad.
- GMB defines the low-end saturated value of keypad brightness. BRL takes effect.

Serial/Ethernet/USB Communication (SCOM) Interface

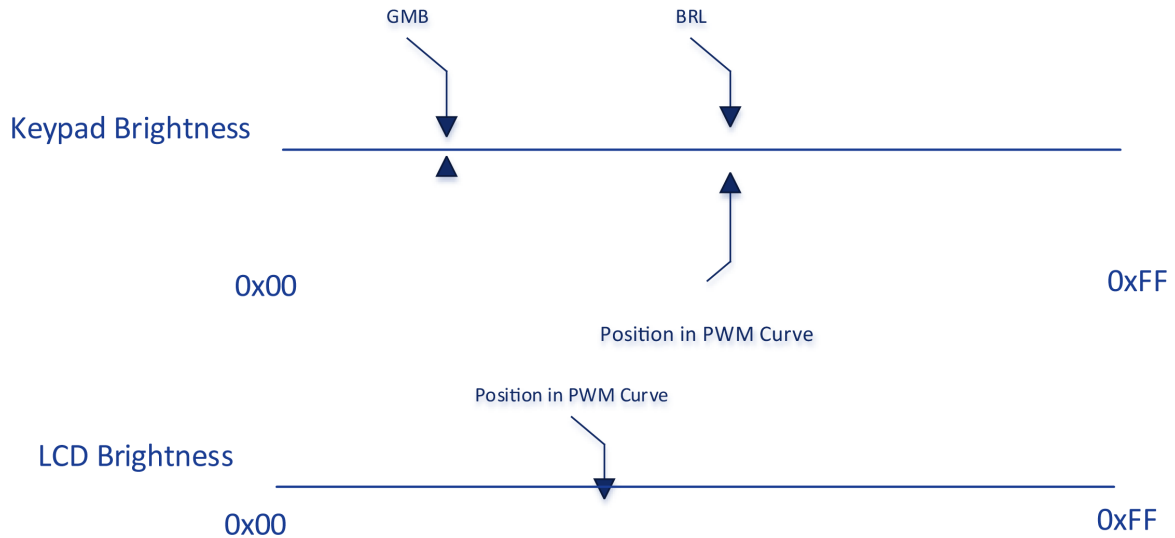

Logic: Keypad Brightness (BRL only)

3: Auto follow Light Sensor

- Use System brightness (BRI, BRM, BRT) and User Brightness (BRU) to calculate the LCD Brightness Step.
- Find the position in LCD brightness PWM curve and generate proper PWM to LCD.
- Convert the position of Light sensor value to Keypad PWM Curve based on gamma.
- Use the converted value to generate proper PWM to keypad.
- GMB defines the low-end saturated value of keypad brightness. **BRL defines the high-end saturated value of keypad brightness.**

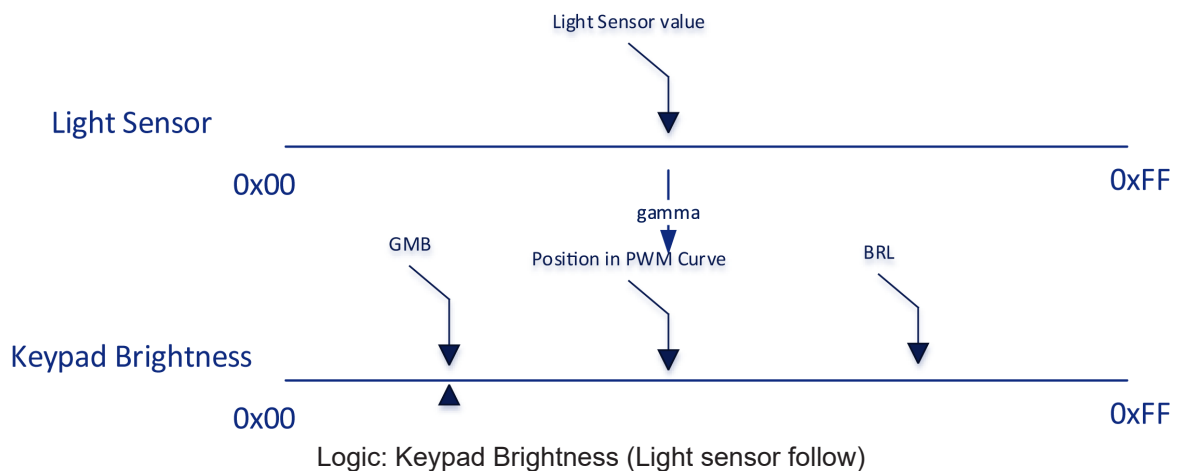

Logic: Keypad Brightness (Light sensor follow)

- 4:**
If Light sensor is failing and GBF is set as "Light sensor follow", the position of PWM Curve is set at 0xFF.

Serial/Ethernet/USB Communication (SCOM) Interface

"LIS" - Read Ambient Light Sensor

This command is used to read the value of the ambient light sensor. This value reads the Channel 0 of the ambient light sensor in system with keypad and embedded light sensor of GDC in GDC system.

Example:

Read Light Sensor:

0x07	0xFF	0x4C	0x49	0x53	0x00	0x11
------	------	------	------	------	------	------

Reply from unit:

0x06	0xFF	0x4C	0x49	0x53	0x02	0x10	0x02	0x34	0xC9
------	------	------	------	------	------	------	------	------	------

DATA0 = Most Significant Byte.

DATA1 = Least Significant Byte.

Read:

When the LIS command is sent with the data 0x4C, it returns an estimated luminance in lux.

Example:

Read luminance in Lux from Light Sensor:

0x07	0xFF	0x4C	0x49	0x53	0x01	0x10	0x4C	0xB3
------	------	------	------	------	------	------	------	------

Reply from unit:

0x06	0xFF	0x4C	0x49	0x53	0x02	0x10	0x01	0x23	0xDB
------	------	------	------	------	------	------	------	------	------

Serial/Ethernet/USB Communication (SCOM) Interface

"ODM" - Outdoor Mode

This command shall set the GDC outdoor mode. The outdoor mode will add 5 second delay to the GDC buttons. However this 5s press is not needed again if 5s does not elapse since last button usage (If one button has been held for more than 5s, any button will respond instantly. If there is user absence for more than 5s ODM is activated again).

Byte #	0	1	2	3	4	5	6	7	8
	0x07	0xFF	0x4F	0x44	0x4D	0x01	IHCHK	OUT	IDCHK

OUT: Describes the status of the OUT variable

Range: Valid levels in table:

0x00	Turn off the outdoor mode
0xFF	Turns on the outdoor mode

After unit reset the value is set to: Nothing is stored.

After microcontroller reset the value is set to: Nothing is stored.

Write:

Sets the outdoor mode to on or off.

Example:

Deactivate Outdoor Mode:

0x07	0xFF	0x4F	0x44	0x4D	0x01	0x18	0x00	0xFF
------	------	------	------	------	------	------	------	------

ACK reply from unit:

0x06	0xFF	0x4F	0x44	0x4D	0x01	0x19	0x00	0xFF
------	------	------	------	------	------	------	------	------

Serial/Ethernet/USB Communication (SCOM) Interface

"REC" - Recall GDC

This command will recall the GDC registers to default values.

BRL = Restored to value in Factory Configuration file.

GMB = Restore to value in Factory Configuration file.

ODM = Restore to value 0x00.

POT = Restore to value 0xFF.

Byte #	0	1	2	3	4	5	6	7	8
	0x07	0xFF	0x52	0x45	0x43	0x01	IHCHK	Recall	IDCHK

RECALL:

Range: Valid levels in table:

0xFF	Recalls GDC
------	-------------

After unit reset the value is set to: Nothing is stored.

After microcontroller reset the value is set to: Nothing is stored.

Write:

Sets the outdoor mode to on or off.

Example:

Activate GDC Recall:

0x07	0xFF	0x52	0x45	0x43	0x01	0x1E	0xFF	0x00
------	------	------	------	------	------	------	------	------

ACK reply from unit:

0x06	0xFF	0x52	0x45	0x43	0x01	0x1F	0xFF	0x00
------	------	------	------	------	------	------	------	------

Serial/Ethernet/USB Communication (SCOM) Interface

"POT" - Backlight Control Interface selection

This command is used to select which HW control method will be used in user backlight control (BRU). The available control methods: SCOM command, GDC keypad and analog potentiometer.

Byte #	0	1	2	3	4	5	6	7	8
	0x07	0xFF	0x50	0x4F	0x54	0x01	IHCHK	DATA	IDCHK

DATA: The data field length is only 1.

Range: Valid levels in table:

0x00	Backlight Controlled by SCOM only (Brightness Button on GDC is disabled.).
0xFF	Backlight controlled by SCOM and GDC keypad.
0x0F	Backlight Controlled by POT meter only.
0xF0	Backlight controlled by SCOM, GDC keypad and POT meter.

Write Example:

Write POT configuration:

0x07	0xFF	0x50	0x4F	0x54	0x01	0x05	0x00	0xFF
------	------	------	------	------	------	------	------	------

Reply from unit:

0x06	0xFF	0x50	0x4F	0x54	0x01	0x06	0x00	0xFF
------	------	------	------	------	------	------	------	------

Read Example:

Read POT configuration:

0x07	0xFF	0x50	0x4F	0x54	0x00	0x06
------	------	------	------	------	------	------

Reply from unit:

0x06	0xFF	0x50	0x4F	0x54	0x01	0x06	0x00	0xFF
------	------	------	------	------	------	------	------	------

Note: If POT is set 0x0F, any BRU write will return NACK.

Serial/Ethernet/USB Communication (SCOM) Interface

"FHA" - Backlight Control Interface selection

This command is used to select which HW control method will be used in user backlight control (BRU). The available control methods: SCOM command, GDC keypad and analog potentiometer.

Byte #	0	1	2	3	4	5	6	7	8
	0x07	0xFF	0x50	0x4F	0x54	0x01	IHCHK	DATA	IDCHK

DATA: The data field length is only 1.

Range: Valid levels in table:

0x00	Backlight controlled by SCOM and keypad. Will set HBYTE bit 5=1, and set TBC bit 4 and 5 in on.	Same function as POT 0xFF
0x99	Backlight Controlled by POT meter only. Will set HBYTE bit 5=0, and set TBC bit 4 and 5 in off.	Same function as POT 0x0F
0xFF	Backlight controlled by SCOM, keypad and POT meter. Will set HBYTE bit 5=1, set TBC bit 4 and 5 in on.	Same function as POT 0xF0

Write Example:

Write FHA configuration:

0x07	0xFF	0x46	0x48	0x41	0x01	0x29	0x00	0xFF
------	------	------	------	------	------	------	------	------

Reply from unit:

0x06	0xFF	0x46	0x48	0x41	0x01	0x29	0x00	0xFF
------	------	------	------	------	------	------	------	------

Read Example:

Read FHA configuration:

0x07	0xFF	0x46	0x48	0x41	0x00	IHCHK
------	------	------	------	------	------	-------

Reply from unit:

0x06	0xFF	0x46	0x48	0x41	0x01	0x2A	0x00	0xFF
------	------	------	------	------	------	------	------	------

Note: If FHA is set 0x99, any BRU write will return NACK.

Serial/Ethernet/USB Communication (SCOM) Interface

SCOM Section: Buzzer

Commands to control the internal Buzzer, or External Buzzer (if available). If External Buzzer is available, commands apply for both internal and external Buzzer at the same time.

"BZZ" - Buzzer Control

This command is used to control buzzer on/off signal. Two modes are available, Single Mode or Cyclic mode. First example below shows Single Operation. Cyclic Operation is explained on next page.

Single Operation (identified in BYTE #5 with 0x01):

Byte #	0	1	2	3	4	5	6	7	8
	0x07	0xFF	0x42	0x5A	0x5A	0x01	0x02	Buzzer	IDCHK

Byte #7 (Buzzer): Describes the status of the Buzzer, in this example Single Operation (either 0x00 for OFF, or 0xFF for ON).

Range: Valid levels in table:

0x00	Turn the buzzer off.
0xFF	Turn the buzzer on.

After unit reset the value is set to: 0x00.

Write:

Set the buzzer status.

Example:

Activate Buzzer:

0x07	0xFF	0x42	0x5A	0x5A	0x01	0x02	0xFF	0x00
------	------	------	------	------	------	------	------	------

ACK reply from the unit:

0x06	0xFF	0x42	0x5A	0x5A	0x01	0x03	0xFF	0x00
------	------	------	------	------	------	------	------	------

Read:

Get the buzzer status. Length of DATA must be zero.

Example:

Get Buzzer Status:

0x07	0xFF	0x42	0x5A	0x5A	0x00	0x02
------	------	------	------	------	------	------

ACK reply from the unit (Buzzer is on):

0x06	0xFF	0x42	0x5A	0x5A	0x01	0x03	0xFF	0x00
------	------	------	------	------	------	------	------	------

Serial/Ethernet/USB Communication (SCOM) Interface

Cyclic Operation (identified in BYTE #5 and #7 with 0x03):

Byte #	0	1	2	3	4	5	6	7	8	9	10
	0x07	0xFF	0x42	0x5A	0x5A	0x03	0x00	Buzzer	ON	OFF	IDCHK

With two more bytes after Byte #7 (Buzzer) value, the BZZ command is able to run the defined pattern of ON and OFF cycle.

Byte #7: Describes the status of the Buzzer, in this example Cyclic Operation (0x03)

Buzzer (Byte #7) can be defined as follows:

0x00	Turn the buzzer off.
0xFF	Turn the buzzer on, run defined ON-OFF pattern forever
0x01-0x0F	Turn the buzzer on, run defined ON-OFF pattern for XX cycles and turn off buzzer

After unit reset the value is set to: 0x00

After microcontroller reset the value is set to: 0x00

ON (Byte #8): Define the Buzzer on time in the pattern.

Range values multiplied in milliseconds:

0x00 - 0xFF	On time = ON x 100ms
-------------	----------------------

OFF (Byte #9): Define the Buzzer off time in the pattern.

Range values multiplied in milliseconds:

0x00 - 0xFF	Off time = OFF x 100ms
-------------	------------------------

After unit reset the value is set to: 0x00

After microcontroller reset the value is set to: 0x00

Both ON and OFF has to be set the value larger than 0x00, in order to trigger the ON-OFF-ON Alarm mode. If at least one of them is set to 0x00, the buzzer is constantly on, when BZZ is turned on. If both are set larger than 0x00, the buzzer is turned on periodically, when BZZ is turned on.

Example:

Activate Buzzer: Cyclic operation - Example Repeat Cycles 3 times (0x03) with 200ms (0x02) ON then 100ms OFF (0x01):

0x07	0xFF	0x42	0x5A	0x5A	0x03	0x00	0x03	0x02	0x01	0xF9
------	------	------	------	------	------	------	------	------	------	------

ACK reply from the unit:

0x06	0xFF	0x42	0x5A	0x5A	0x03	0x01	0x03	0x02	0x01	0xF9
------	------	------	------	------	------	------	------	------	------	------

Serial/Ethernet/USB Communication (SCOM) Interface

SCOM Section: Service

Commands to review Service related information available for the unit.

"SWI" - Main Software Version Query

This query is sent to the unit in order to get the microcontroller software version ID. Length of DATA must be zero. The DATA field will be an ASCII text string indicating the software version. The Maximum length of DATA is 18 bytes.

Example:

Get Software Version:

0x07	0xFF	0x53	0x57	0x49	0x00	0x06
------	------	------	------	------	------	------

Reply from unit:

0x06	0xFF	0x53	0x57	0x49	0x0D	0x07	0x46	0x57	0x31	0x30
0x30	0x30	0x30	0x32	0x2D	0x30	0x41	0x30	0x31	0x40	

0x?? = Where ?? are HEX value (ASCII chars A-Z, 0-9 + symbols).

"SWV" - Video Scaler Software Version Query

This query is sent to video scaler in order to get the firmware version ID. Length of DATA must be zero. The DATA field will be an ASCII text string indicating the software version. The Maximum length of DATA is 18 bytes.

The SWV command will be forwarded to the video scaler. The microcontroller does not need to process this data other than forwarding request and reply.

Example:

Get Software Version:

0x07	0xFF	0x53	0x57	0x49	0x00	0x06
------	------	------	------	------	------	------

Reply from unit:

0x06	0xFF	0x53	0x57	0x49	0x0D	0x07	0x46	0x57	0x32	0x30
0x30	0x30	0x30	0x31	0x2D	0x30	0x41	0x30	0x31	0x40	

0x?? = Where ?? are HEX value (ASCII chars A-Z, 0-9 + symbols).

Serial/Ethernet/USB Communication (SCOM) Interface

"TYP" - Type/Model Number Query

This query is sent to the unit in order to identify the unit type by its model number / part number. Length of DATA shall be zero. The unit will reply to this command with an ACK attention code. The DATA field should be translated to an ASCII text string which indicates the specified Type/Model Number, e.g: "HD08T30MMDMA1FAGA". The maximum length of the Type Number is 21 bytes. The command should not return bytes with value 0xFF.

Example:

Read Type/Model Number:

0x07	0xFF	0x54	0x59	0x50	0x00	0xFC
------	------	------	------	------	------	------

Reply from unit:

0x06	0xFF	0x54	0x59	0x50	0x11	0xEC	0x48	0x44	0x30	0x38
0x54	0x33	0x30	0x4D	0x4D	0x43	0x4D	0x41	0x31	0x46	0x41
0x47	0x41	0xA9								

0x?? = Where ?? are HEX value (ASCII chars A-Z, 0-9 + symbols).

"SNB" - Serial Number Query

This query is sent to the unit in order to identify the unit serial number. Length of DATA shall be zero. The unit will reply to this command with an ACK attention code. The DATA field will be set to an ASCII text string to indicate the specified Serial Number, e.g: "123456". The maximum length of DATA is 6 bytes. The command should not return a byte which is 0xFF.

Example:

Command Unit Serial Number:

0x07	0xFF	0x53	0x4E	0x42	0x00	0x16
------	------	------	------	------	------	------

Acknowledge Type/Model Number example "123456":

0x06	0xFF	0x53	0x4E	0x42	0x06	0x12	0x31	0x32	0x33	0x34
0x35	0x36	0xCA								

Serial/Ethernet/USB Communication (SCOM) Interface

"SCI" - Store Customer Service ID

This command is used to program the Customer Service ID. The maximum length of the DATA field is 16 bytes. All ASCII characters are allowed.

After unit reset the value is set to: last stored value.

After microcontroller reset the value is set to: last stored value. (All Bytes = 0xFF if not previously stored).

Example:

Write SCI:

0x07	0xFF	0x53	0x43	0x49	0x02	0x18	0x30	0x31	0x9E
------	------	------	------	------	------	------	------	------	------

ACK Reply from unit:

0x06	0xFF	0x53	0x43	0x49	0x02	0x19	0x30	0x31	0x9E
------	------	------	------	------	------	------	------	------	------

"CSI" - Read Customer Service ID

This command is used to read the Customer Service ID. The length of DATA is zero bytes.

The command should not return bytes with value 0xFF.

Example:

Read "CSI":

0x07	0xFF	0x43	0x53	0x49	0x00	0x1A
------	------	------	------	------	------	------

ACK Reply from unit:

0x06	0xFF	0x43	0x53	0x49	0x02	0x19	0x30	0x31	0x9E
------	------	------	------	------	------	------	------	------	------

"ETC" - Elapsed Time Counter

This command will return the hours the video scaler has been on. The DATA field should be translated to an ASCII text string which shows the elapsed hours.

Example:

Get ETC:

0x07	0xFF	0x45	0x54	0x43	0x01	0x19
------	------	------	------	------	------	------

ACK reply from unit: "00004" hours:

0x06	0xFF	0x45	0x54	0x43	0x05	0x19	0x30	0x30	0x30	0x30
0x34	0x0B									

Serial/Ethernet/USB Communication (SCOM) Interface

"MAN" - Read Manufacturer data

This command is used to read the Manufacturer ID. The length of DATA is zero bytes. The command always returns "JHD".

The purpose of defining this command is to be compatible with old SCOM command.

Example:

Read "MAN":

0x07	0xFF	0x4D	0x41	0x4E	0x00	0x1D
------	------	------	------	------	------	------

ACK Reply from unit:

0x06	0xFF	0x4D	0x41	0x4E	0x03	0x1B	0x4A	0x48	0x44	0x29
------	------	------	------	------	------	------	------	------	------	------

"TMP" - Read Temperature Sensor

The unit features temperature sensor that measures the temperature inside. The TMP command can be used to read the current sensor temperature. The length of DATA shall be 1 or 2 and contain the following:

Data length is 1, return the value from temperature sensor 0x00

Byte #	0	1	2	3	4	5	6	7	8
	0x07	0xFF	0x54	0x4D	0x50	0x01	IHCHK	TMP	IDCHK

Data length is 2, return the value from assigned temperature sensor

Byte #	0	1	2	3	4	5	6	7	8	9
	0x07	0xFF	0x54	0x4D	0x50	0x02	IHCHK	TMP	NUM	IDCHK

TMP: A value describing the Read Temperature Type.

Range: Valid levels in table:

0x52 = 'R'	Read Current Temperature from on-board Sensor
------------	---

NUM: Index of Temperature Sensors

0x00	On-board main sensor
0x01~0x0F	Remote sensor

Read Current Temperature:

The unit will reply to this command with an ASCII string indication the temperature in °C, e.g.: "+027.5°C". Read accuracy is ±0.5°C.

Example:

Get Current Temperature:

0x07	0xFF	0x54	0x4D	0x50	0x02	0x07	0x52	0x00	0xAD
------	------	------	------	------	------	------	------	------	------

ACK reply from unit: "+036.5°C"

0x06	0xFF	0x54	0x4D	0x50	0x08	0x01	0x2B	0x30	0x33	0x36
0x2E	0x35	0xBA	0x43	0xDD						

Serial/Ethernet/USB Communication (SCOM) Interface

"VER" - Read Specific Type

This command is used to read the specific Type segment in Type Number. The returned value is the three characters from pos 8 to 10 in stored Type Number. If there is no type number stored, return 0 byte.

For example, if the type number is "HD5T22MVDMA1AAAAAA", VER should return "MVD"

The purpose of defining this command is to be compatible with old SCOM command.

Example:

Read "Ver":

0x07	0xFF	0x56	0x45	0x52	0x00	0x0C
------	------	------	------	------	------	------

ACK Reply from unit:

0x06	0xFF	0x56	0x45	0x52	0x03	0x0A	0x4A	0x48	0x44	0x29
------	------	------	------	------	------	------	------	------	------	------

"FWV" - Read Firmware information

This command will be used to read various firmware versions.

The purpose of defining this command is to be compatible with old SCOM command.

Byte #	0	1	2	3	4	5	6	7	8
	0x07	0xFF	0x46	0x57	0x56	0x01	IHCHK	FW Type	IDCHK

FW TYPE: Specify the firmware type.

Range: Valid values in table

Device Type	Value	Comment
Microcontroller Firmware	0x00	Same as SWI
Video Scaler	0x01	Same as SWV
Microcontroller Config File	0x02	

Example:

Get Microcontroller Firmware :

0x07	0xFF	0x46	0x57	0x56	0x01	0x19	0x00	0xFF
------	------	------	------	------	------	------	------	------

ACK reply from unit: "00004"

0x06	0xFF	0x46	0x57	0x56	0x05	0x19	0x30	0x30	0x30	0x30
0x34	0x0B									

Serial/Ethernet/USB Communication (SCOM) Interface

SCOM Section: Interface

Commands to control the global settings that affects communication/protocol behaviour.

"CBR" - COM Ports Baudrate Configuration

This command is used to configure the baudrate on COM ports. The command will select between RS232 and RS485 port. There are two available options for baudrate: 9600 and 115200.

This command to configure baudrate on:

Byte #	0	1	2	3	4	5	6	7	8	9
	0x07	0xFF	0x43	0x42	0x52	0x02	IHCHK	COM	BAUD	IDCHK

COM: Define the COM Port.

Range: Valid levels in table:

0x00	RS232 Port
0xFF	RS485/422 Port

Baudrate: Define the COM Port's baudrate.

Range: Valid levels in table:

0x00	9600 bps
0xFF	115200 bps

After unit reset the value is set to: last stored value.

After microcontroller reset the value is set to: last stored value.

(All bytes = 0x00 if the type number is not yet programmed)

Write:

Set the COM Baudrate.

Example:

Set RS232 Port to 9600 bps:

0x07	0xFF	0x43	0x42	0x52	0x02	0x20	0x00	0x00	0xFF
------	------	------	------	------	------	------	------	------	------

ACK reply from unit:

0x06	0xFF	0x43	0x42	0x52	0x02	0x21	0x00	0x00	0xFF
------	------	------	------	------	------	------	------	------	------

Read:

Get the COM port baudrate status. Length of DATA must be 1.

Example:

Get RS232 Baudrate:

0x07	0xFF	0x43	0x42	0x52	0x01	0x21	0x00	0xFF
------	------	------	------	------	------	------	------	------

ACK reply from unit:

0x06	0xFF	0x43	0x42	0x52	0x02	0x21	0x00	0xFF	0x00
------	------	------	------	------	------	------	------	------	------

Serial/Ethernet/USB Communication (SCOM) Interface

"BAK" - Broadcast Acknowledgement

This command is used to set turn on/off broadcast acknowledgement of the received message on RS485/422 port. The purpose of adding this command is to simplify the message processing on computer side.

Setting will be changed after sending an answer.

Byte #	0	1	2	3	4	5	6	7	8
	0x07	0xFF	0x42	0x41	0x4B	0x01	IHCHK	ONOFF	IDCHK

ONOFF: Enable/Disable ACK on Broadcast messages.

Range: Valid levels in table:

0x00	Broadcast ACK OFF
0xFF	Broadcast ACK ON

After unit reset the value is set to: last stored value.

After microcontroller reset the value is set to: last stored value. (All bytes = 0xFF if the type number is not yet programmed). By factory defaults BAK is set to ON. (Always reply to commands).

Write Example:

Enable Broadcast ACK:

0x07	0xFF	0x42	0x41	0x4B	0x01	0x2A	0xFF	0x00
------	------	------	------	------	------	------	------	------

ACK reply from unit:

0x06	0xFF	0x42	0x41	0x4B	0x01	0x2B	0xFF	0x00
------	------	------	------	------	------	------	------	------

Read Example:

Get Broadcast ACK status:

0x07	0xFF	0x42	0x41	0x4B	0x00	0x2B
------	------	------	------	------	------	------

ACK reply from unit ACK is off:

0x06	0xFF	0x42	0x41	0x4B	0x01	0x2B	0x00	0xFF
------	------	------	------	------	------	------	------	------

Serial/Ethernet/USB Communication (SCOM) Interface

SCOM Section: ECDIS

Commands for downloading ECDIS Color Table files (if stored in memory and performed by factory).

"DLN" - Download package

This command shall be sent to request a specific data packet stored in the microcontroller. The DATA field shall contain the packet number being requested; the byte in the DATA field represents a hexadecimal word (00 to FF) identifying the block of data to be downloaded. The total number of packets available is found by issuing the "DL?" command.

Byte #	0	1	2	3	4	5	6	7	8
	0x07	0xFF	0x44	0x4C	0x4E	0x01	IHCHK	DATA	IDCHK

DATA: The packet number being requested.

If the data checksum and packet number is valid, the microcontroller shall reply to this command with an ACK attention code, the hexadecimal packet number, a separator ('-'), and the ASCII packet data. The maximum DATA field size for a packet of data shall be 32 bytes per message; therefore the DATA field in the reply shall be a maximum length of 32 bytes. The DATA field of the message is not required to be of maximum length (it may be smaller than 32 bytes).

Example:

Requesting package 80 (active ECDIS table):

0x07	0xFF	0x44	0x4C	0x4E	0x01	0x1A	0x50	0xAF
------	------	------	------	------	------	------	------	------

Reply from unit is 1 byte of packet number (0x50), a separator '-' and Human Readable Text 'TEST'

0x06	0xFF	0x44	0x4C	0x4E	0x06	0x16	0x50	'-'	'T'	'E'
'S'	'T'	0x42								

Active ECDIS table is stored first and can be read with only specifying the packed nr. To read from the other tables, another byte is added for table nr. Active ECDIS table is determined by Calibration mode.

The DATA field shall contain the packet number being requested and table nr; the first byte in the DATA field represents a hexadecimal entry (0x00 to 0xFF) identifying the block of data to be downloaded. The total number of packets available is found by issuing the "DL?" command. The second byte in the DATA represents the table nr from 0-x.

Example:

Requesting package 80 of table 1:

0x07	0xFF	0x44	0x4C	0x4E	0x02	0x19	0x50	0x01	0xAE
------	------	------	------	------	------	------	------	------	------

Reply from unit is 1 byte of packet number (0x50), a separator '-' and Human Readable Text 'TEST'

0x06	0xFF	0x44	0x4C	0x4E	0x06	0x5F	0x50	'-'	'T'	'E'
'S'	'T'	0x42								

Serial/Ethernet/USB Communication (SCOM) Interface

"DL?" - Request Number of packages available

This command is used to request the number of packets available for download. The DATA field of the command shall contain no data when requesting size of active ECDIS.

Byte #	0	1	2	3	4	5	6
	0x07	0xFF	0x44	0x4C	0x3F	0x00	IHCHK

The microcontroller shall reply to this command with an ACK attention code. The number of packets shall be sent as 1 byte in the DATA field of the response. This byte shall indicate the resulting number of packets; a value of 0x00 shall indicate zero packets, while a value of 0xFF shall indicate that there are 255 packets to download.

If there are more tables the DATA field shall contain the table nr from 0-X.

If the Calibration mode is set to "Calibration VGA", the Data field will contain table nr 0.

If the Calibration mode is set to "Calibration DVI", the Data field will contain table nr 1.

If the Calibration mode is set to "Calibration DP/USB-C", the Data field will contain table nr 2.

If the Calibration mode is set to "Calibration HDMI", the Data field will contain table nr 3

If the Calibration mode is set to "No Calibration", or if the Data table is not present for the selected calibration mode, the microcontroller will reply with a nak.

The number of packets necessary to deliver the entire block of data is defined as:

Packets = (Size of Data / (32 bytes per packet - 2 overhead bytes per packet)) rounded up to the nearest whole number.

Examples:

Packets = 3049 bytes / 32 data bytes per packet = 96.6 rounded up to 97 Packets

Example:

Requesting size of table 0:

0x07	0xFF	0x44	0x4C	0x3F	0x00	0x2A
------	------	------	------	------	------	------

Acknowledge: DL? indicates 4 (0,1,2,3) available packets:

0x06	0xFF	0x44	0x4C	0x3F	0x01	0x2A	0x01	0xFE
------	------	------	------	------	------	------	------	------

Serial/Ethernet/USB Communication (SCOM) Interface

"CAL" - Calibration brightness level

This command inquires the GDC calibration Level. For units that are ECDIS calibrated from factory, the LED pattern (ECDIS) indicates that the backlight/brightness is at calibrated level.

Byte #	0	1	2	3	4	5	6	7	8
	0x07	0xFF	0x43	0x41	0x4C	0x01	IHCHK	CAL	IDCHK

CAL: Inquiry Mark.

0x3F Inquiry the active CAL value

Read:

Get the calibration level. The length of DATA should be 1 and DATA0 = 0x3F ('?').

Example:

Get calibration level:

0x07	0xFF	0x43	0x41	0x4C	0x01	0xB2	0x3F	0xC0
------	------	------	------	------	------	------	------	------

ACK reply from unit (CAL level is 0xAA):

0x06	0xFF	0x43	0x41	0x4C	0x01	0xB3	0xAA	0x55
------	------	------	------	------	------	------	------	------

Serial/Ethernet/USB Communication (SCOM) Interface

SCOM Section: Factory

Commands related to configuration of global Factory preset.

"RCF" - Recall Factory Configuration

This command will recall the original copy of factory configuration. The user copy of configuration will be replaced and overwritten completely.

Affected Configuration Type:

- 1: Brightness.
- 2: Backlight & GDC & FAN PWM lookup table.
- 3: Buzzer Configuration.
- 4: GDC configuration.

Byte #	0	1	2	3	4	5	6	7	8
	0x07	0xFF	0x52	0x43	0x46	0x01	IHCHK	Recall	IDCHK

Recall:

Range: Valid levels in table:

0xFF	Recalls factory configuration
------	-------------------------------

After unit reset the value is set to: Nothing is stored.

After microcontroller reset the value is set to: Nothing is stored.

Example:

Activate Factory Configuration Recall:

0x07	0xFF	0x52	0x43	0x46	0x01	0x1D	0xFF	0x00
------	------	------	------	------	------	------	------	------

ACK reply from unit:

0x06	0xFF	0x52	0x43	0x46	0x01	0x1E	0xFF	0x00
------	------	------	------	------	------	------	------	------

Serial/Ethernet/USB Communication (SCOM) Interface

SCOM Section: Power

Commands related to configuration of global Power settings.

"PWR" - Power On/Off/Sleep unit

This command is used to power on/off the unit or put the unit in sleep mode.

Byte #	0	1	2	3	4	5	6	7	8
	0x07	0xFF	0x50	0x57	0x52	0x01	IHCHK	Power	IDCHK

Power:

Range: Valid levels in table:

0x00	Power Off
0x0F	Sleep Mode (Stand by)
0xFF	Power On

After unit reset the value is set to: Nothing is stored

After microcontroller reset the value is set to: Nothing is stored

Write Example:

Power unit:

0x07	0xFF	0x50	0x57	0x52	0x01	0xFF	0xFF	0x00
------	------	------	------	------	------	------	------	------

ACK reply from unit:

0x06	0xFF	0x50	0x57	0x52	0x01	0x00	0xFF	0x00
------	------	------	------	------	------	------	------	------

Read Example:

Ask for power state

0x07	0xFF	0x50	0x57	0x52	0x00	0x00
------	------	------	------	------	------	------

ACK reply from unit:

0x06	0xFF	0x50	0x57	0x52	0x01	0x00	0xFF	0x00
------	------	------	------	------	------	------	------	------

Note:

- 1: PWR will give response right after the power state change is started. But due to the latency of power up sequence, the new power state may be activated after the command is sent.
- 2: Change to the current power state, always return ACK.

Serial/Ethernet/USB Communication (SCOM) Interface

'DST' - Display State

This command is sent to the unit to control the unit on/off or query the on/off state of the unit.

Byte #	0	1	2	3	4	5	6	7	8
	0x07	0xFF	0x50	0x57	0x52	0x01	IHCHK	State	IDCHK

State:

0x00	Power Off
0xFF	Power On
0x3F	Query the state of the unit. The returned DATA field will indicate the state. 0x00 = Unit is off. 0xFF = Unit is on. (including sleep)

After computer reset the value is set to: Nothing is stored

After UC reset the value is set to: Nothing is stored

Write Example:

Power unit:

0x07	0xFF	0x44	0x53	0x54	0x01	0x0D	0x3F	0xC0
------	------	------	------	------	------	------	------	------

ACK reply from unit:

0x06	0xFF	0x44	0x53	0x54	0x01	0x0E	0xFF	0x00
------	------	------	------	------	------	------	------	------

Serial/Ethernet/USB Communication (SCOM) Interface

SCOM Section: Video Scaler

Commands related to configuration of the internal Video Controller logic and behaviour including function related to the On Screen Display Menu (OSD).

"VUR" - Read User Configuration from Video Scaler

The command reads the user saved configuration from video scaler. The configuration saves OSD settings. The user configuration table size is 256 bytes.

The read process will be divided into 4 packets (64 bytes in each).

Byte #	0	1	2	3	4	5	6	7	8	9
	0x07	0xFF	0x56	0x55	0x52	0x02	IHCHK	Bank	Packet Number	IDCHK

Bank:

Defines which user-saved configuration are in request. Range: 0~7.

Packet Number:

Defines which packet to be downloaded. Range: 0~3.

Write Example:

Requesting package 0 and bank 0:

0x07	0xFF	0x56	0x55	0x52	0x02	0xFA	0x00	0x00	0xFF
------	------	------	------	------	------	------	------	------	------

Reply from unit:

0x06	0xFF	0x56	0x55	0x52	0x65	0x98	0x01	0x01	0x00
...	0x00	0x00	0x00	0xFD					

Serial/Ethernet/USB Communication (SCOM) Interface

"VUS" - Store User Configuration to Video Scaler

The command write the user configuration to video scaler. The user configuration table size is 256 bytes.

Note: the command is passed to VS only.

The read process will be divided into 4 packets (64 bytes in each).

Byte #	0	1	2	3	4	5	6	7	8	9	10	...	72	73
	0x07	0xFF	0x56	0x55	0x53	0x42	IHCHK	Bank	Packet Number	0xFF	0x02	...	0x00	IDCHK

Bank:

Defines which user-saved configuration are in request. Range: 0~7.

Packet Number:

Defines which packet to be downloaded. Range: 0~3.

Write Example:

Write package 0 to bank 1

0x07	0xFF	0x56	0x55	0x53	0x42	0xB9	0x00	0x01	0x00	0x02
...	0x00	0xFF								

Reply from unit:

0x06	0xFF	0x56	0x55	0x53	0x02	0xFA	0x00	0x00	0xFF
------	------	------	------	------	------	------	------	------	------

Serial/Ethernet/USB Communication (SCOM) Interface

SCOM Section: OSD Control Functionality

This command is used to provide remote access to OSD menu and handle the internal communication towards the video scaler.

"MOD" - Operation Mode Selection

This global command is used to select the operation mode of the firmware and affects the commands listed in the "MCC" section on next page. The aim of this function is to provide backwards compatibility for the Series X MMD Generation (G2) models which enables them to receive and respond to SCOM commands and queries like the previous Series X MMD Generation 1 (G1) models. By factory default (unless customer specified) is set to Series X MMD Generation 2 (G2) - GEV2 mode.

Note: Review the differences in the "MCC Commands List" on the following pages for details.

Reference: Engineering Change Notification (ECN):

<https://www.hattelandtechnology.com/product-notifications/update-series-x-maritime-multi-display-mmd-firmware-update>

GEV1 = Reference to Series X Maritime Multi Display (MMD) - Generation 1 (G1) - HD xxT21xxD models.

GEV2 = Reference to Series X Maritime Multi Display (MMD) - Generation 2 (G2) - HD xxT22xxD models and Multi Vision Displays (MVD) - HD xxT22 MVD models.

Format:

Byte #	0	1	2	3	4	5	6	7	8
	0x07	0xFF	0x4D	0x4F	0x44	0x01	IHCHK	DATA	IDCHK

DATA:

The data field length is only 1.

Range: Valid levels in table:

0x00	GEV2 Mode
0x01	GEV1 compatible mode

After unit reset the value is set to: last stored value.

0x00 is the default value.

Write Example:

Write MOD configuration "GEV1 compatible mode"

0x07	0xFF	0x4D	0x4F	0x44	0x01	0x18	0x01	0xFE
------	------	------	------	------	------	------	------	------

Reply from unit:

0x06	0xFF	0x4D	0x4F	0x44	0x01	0x19	0x01	0xFE
------	------	------	------	------	------	------	------	------

Read Example:

Read MOD configuration:

0x07	0xFF	0x4D	0x4F	0x44	0x00	0x19
------	------	------	------	------	------	------

Reply from unit:

0x06	0xFF	0x4D	0x4F	0x44	0x01	0x19	0x00	0xFF
------	------	------	------	------	------	------	------	------

Serial/Ethernet/USB Communication (SCOM) Interface

"MCC" - OSD Control Functionality

Each MCC command will specify a OSD Command ID in the first data byte. The OSD Command ID represents an OSD menu setting item or internal function.

Byte #	0	1	2	3	4	5	6	7	8	...	7+LEN	8+LEN
	0x07	0xFF	0x4D	0x43	0x43	LEN	IHCHK	Command ID	Data1		Datax	IDCHK

Command ID:

Supported Command ID in video scaler Command list.

Data:

Defines the data of option numbers, inquiry, reset and so on.

Write Example:

MCC Command "OSD Factory Default" (0xCE)

0x07	0xFF	0x4D	0x43	0x43	0x01	0x25	0xCE	0x31
------	------	------	------	------	------	------	------	------

Reply from unit of "1" successfull:

0x06	0xFF	0x4D	0x43	0x43	0x01	0x26	0x01	0xFE
------	------	------	------	------	------	------	------	------

Serial/Ethernet/USB Communication (SCOM) Interface - MCC Commands

MCC Commands List

NOTE: A char between the ' ' indicate an ASCII value. Example '1' = 0x31.

A complete HEX, ASCII, BIN and Character table overview are available in the APPENDIX chapter.

Some commands have footnotes, see references at the end of this table. "VIC2" = Series X Generation 3 (G3) models, "GEV2" = Series X Generation 2 (G2) models:

Reference Compatibility: <https://www.hattelandtechnology.com/product-notifications/firmware-update-for-32-and-55-inch-products>

<https://www.hattelandtechnology.com/product-notifications/video-scaler-firmware-update-affecting-series-x-g2-mmd-hm-24-cmd-and-series-1-g2-mmd>

Function	Data	Description	VIC2	GEV2	Differences
Brightness control Important: Not to be confused with "BRU" - User Brightness Control command.	0x81, nn '+' '-' 'r' 'R' '?'	Set brightness = value / increment / decrement / reset / query	Brightness Range=0"0"0"0"~2"5"5" Default = '1"2"8'	Brightness Range=0"0"0"0"~2"5"5" Default = '1"2"8'	Same as GEV2
Contrast control	0x82, 'a' 'A', nn '+' '-' 'r' 'R' '?'	Set contrast = value / increment / decrement / reset / query	Contrast Range=0"0"0"~2"5"5" Default = '1"2"8'	Contrast Range=0"0"0"~2"5"5" Default = '1"2"8'	Same as GEV2
Saturation control	0x83, nn '+' '-' 'r' 'R' '?'	Set Saturation = value / increment / decrement / reset / query	Saturation Range=0"0"0"~2"5"5" Default = '1"2"8'	Saturation Range=0"0"0"~2"5"5" Default = '1"2"8'	Same as GEV2
Hue control	0x84, nn '+' '-' 'r' 'R' '?'	Set Hue = value / increment / decrement / reset / query	Hue Range=0"0"0"~2"5"5" Default = '1"2"8'	Hue Range=0"0"0"~2"5"5" Default = '1"2"8'	Same as GEV2
Manual Phase control	0x85, nn '+' '-' '?'	Set dot clock phase = value / increment / decrement / query	Phase Range=0"0"0"~2"5"5"	Phase Range=0"0"0"~2"5"5"	Same as GEV2
Image H position	0x86, nn '+' '-' 'r' 'R' '?'	Set image Hpos = value / increment / decrement / reset / query Analog Only	Hpos Range=0"0"0"~2"5"5" Default = '1"2"8'	Hpos Range=0"0"0"~2"5"5" Default = '1"2"8'	Same as GEV2
Image V position	0x87, nn '+' '-' 'r' 'R' '?'	Set image Vpos = value / increment / decrement / reset / query Analog Only	Vpos Range=0"0"0"~2"5"5" Default = '1"2"8'	Vpos Range=0"0"0"~2"5"5" Default = '1"2"8'	Same as GEV2
Auto Source Select	0x88, n 'r' 'R' '?'	Set Auto Source Select = disable / enable / reset / query	'0' - disable '1' - enable (default)	'0' - disable '1' - enable (default)	Same as GEV2
OSD mode	0x89, n 'r' 'R' '?'	Set OSD mode = full / simple / reset / query	'0' - Advanced (default) '1' - Basic '2' - Service	'0' - Advanced (default) '1' - Basic '2' - Service	Same as GEV2
Sharpness	0x8A, nn '+' '-' 'r' 'R' '?'	Set sharpness = value / increment / decrement / reset / query	Sharpness Range=0"0"0"~2"5"5" Default = '1"2"8'	Sharpness Range=0"0"0"~2"5"5" Default = '1"2"8'	Same as GEV2
Manual Frequency control	0x8B, nn '+' '-' '?'	Set dot clock frequency = value / increment / decrement / query	Clock Range=0"0"0"~2"5"5"	Clock Range=0"0"0"~2"5"5"	Same as GEV2
Scaling Mode	0x8C, n 'r' 'R' '?'	Set image graphic scaling = value / reset / query	'0' - Full (default) '1' - 4:3 '2' - 5:4 '3' - Native	'0' - Fill Screen (default) '1' - One To One '2' - Fill to aspect ratio	Similar as GEV2.

Serial/Ethernet/USB Communication (SCOM) Interface - MCC Commands

Function	Data	Description	VIC2	GEV2	Differences
OSD lock mode	0x8D, n 'r' 'R' '?'	Set OSD mode = normal / lock / reset / query	'0' - Disabled (default) '1' - Enabled	'0' - normal (default) '1' - FULL Protect '2' - Menu Protect	Almost same as GEV2
Auto adjustment	0x8F, n 'r' 'R' '?'	Set auto adjust = on / off	'0' - off '1' - on (default)	'0' - off '1' - on (default)	Same as GEV2
OSD H position	0x90, nn '+' '-' 'r' 'R' '?'	Set OSD Hpos = value / increment / decrement / reset / query	OSD Hpos Range='0'0'~'2'5'5' Default = '2'5'5'	OSD Hpos Range='0'0'~'2'5'5' Default = '2'5'5'	Same as GEV2
OSD V position	0x91, n '+' '-' 'r' 'R' '?'	Set OSD Vpos = value / increment / decrement / reset / query	OSD Vpos Range='0'0'~'2'5'5' Default = '2'5'5'	OSD Vpos Range='0'0'~'2'5'5' Default = '2'5'5'	Same as GEV2
OSD Transparency	0x92, nn '+' '-' 'r' 'R' '?'	Set OSD transparency = value / increment / decrement / reset / query	Range = '0'~'7' Default = '0'	OSD transparency Range = '0'~'7' Default = '0'	Same as GEV2
Select OSD menu timeout	0x93, nn '+' '-' 'r' 'R' '?'	Set OSD menu timeout = value / increment / decrement / reset / query	OSD menu timeout Range = '0'0'~'1'E' Default = '0'A'	OSD menu timeout Range = '0'0'~'1'E' Default = '0'A'	Same as GEV2
Select OSD language	0x95, n 'r' 'R' '?'	Select language = value / reset / query	Language '0' - English (default) '1' - French '2' - German '3' - Italian '4' - Spanish '5' - Japanese '6' - Simplified Chinese '7' - Norwegian	Language '0' - English (default) '1' - French '2' - German '3' - Italian '4' - Spanish '5' - Japanese '6' - Simplified Chinese '7' - Norwegian	Same as GEV2
Filter	0x96, n 'r' 'R' '?'	Select Filter = Enable (on) / Disable (off) / reset / query	N/A	'0' - Off (default) '1' - On	Not supported for VIC2
Main input select	0x98, n 'r' 'R' '?'	Select input main = value / reset / query	0x00 - HDMI 0x10 - VGA 0x30 - DP 0x31 - USB-C 0x01 - DVI1 (Exp. card only)	0x00 - Digital 1 (default) 0x01 - Digital 2 0x10 - Analog RGB1 0x11 - Analog RGB2 0x20 - Composite 1 0x21 - Composite 2 0x22 - Composite 3 0x30 - DisplayPort1	Different Input ID between GEV2 and VIC2
Communication mode	0x99, n 'r' 'R' '?'	Select Communication mode = value / reset / query	'2' - 2 wire RS485 '3' - 4 wire RS422 (Default)	'0' - RS232 (Default) '1' - Ethernet '2' - 2wire RS485 '3' - 4wire RS422 '4' - USB '5' - Enable RS232 FW Download	Removed "0", "1", "4" and "5"
PIP Mode	0x9A, n 'r' 'R' '?'	Select PIP Mode = value / reset / query	N/A	'0' - PIP Off (default) '1' - PIP Child '2' - PIP Wide '3' - PIP Split	Not supported for VIC2

Serial/Ethernet/USB Communication (SCOM) Interface - MCC Commands

Function	Data	Description	VIC2	GEV2	Differences
Gamma value select	0x9D, n 'r' 'R' '?'	Select Gamma value = value / reset / query	Gamma value '0' - No Calibration '1' - DVI Calibration (Exp. card) '2' - VGA Calibration '3' - DP Calibration '4' - HDMI Calibration	Gamma value '0' - No Calibration (default) '1' - Calibration DVI '2' - Calibration VGA '3' - Calibration DP '4' - Calibration Composite	New video inputs
Power Control	0x9F, n '?'		'0' - Power Off '1' - Power On	'0' - Off '1' - On Map PWR command	Same as GEV2
Hot Key Assignment	0xA0, '1' '2', n 'r' 'R' '?'	Set Hot Key = value / reset / query '1' for hot key 1 = '1', n 'r' 'R' '?' '2' for hot key 2 = '2', n 'r' 'R' '?'	'0' - Brightness '2' - Main source '5' - Scaling '7' - Test pattern, '8' - Language '9' - No function	'0' - Brightness '1' - PIP size '2' - Main source '3' - Second source '4' - PIP mode '5' - Scaling '6' - Swap '7' - Test pattern '8' - Language '9' - No function (default) 'A' - Analog1 'B' - Analog2 'C' - Digital1 'D' - Digital2 'E' - Composite1 'F' - Composite2 'G' - Composite3 'H' - DisplayPort	Some function removed
PIP brightness control	0xA2, nn '+' '-' 'r' 'R' '?'	Set PIP brightness = value / increment / decrement / reset / query	N/A	PIP window brightness Range=0"0"~2"5"5" Default = '1"2"8'	Not supported for VIC2
PIP contrast control	0xA3, nn '+' '-' 'r' 'R' '?'	Set PIP contrast = value / increment / decrement / reset / query	N/A	PIP window contrast Range=0"0"~2"5"5" Default = '1"2"8'	Not supported for VIC2
PIP H position	0xA4, nn '+' '-' 'r' 'R' '?'	Set PIP H pos = value / increment / decrement / reset / query	N/A	PIP H pos Range=0"0"~2"5"5" Default = '1"2"8'	Not supported for VIC2
PIP V position	0xA5, nn '+' '-' 'r' 'R' '?'	Set PIP V pos = value / increment / decrement / reset / query	N/A	PIP V pos Range=0"0"~2"5"5" Default = '2"5"5'	Not supported for VIC2
PIP window size select	0xA6, n '+' '-' 'r' 'R' '?'	Set PIP window size = value / increment / decrement / reset / query	N/A	PIP V window size Range = '1'~'7' Default = '7'	Not supported for VIC2

Serial/Ethernet/USB Communication (SCOM) Interface - MCC Commands

Function	Data	Description	VIC2	GEV2	Differences
Second source select	0xA7, n 'r' 'R' '?'	Select input second = value / reset / query	N/A	0x00 - Digital 1 (default) 0x01 - Digital 2 0x10 - Analog RGB1 0x11 - Analog RGB2 0x20 - Composite 1 0x21 - Composite 2 0x22 - Composite 3 0x30 - DisplayPort1	Not supported for VIC2
Color Temperature Select	0xB3, n 'r' 'R' '?'	Set Color Temperature = value / reset / query	Color temperature '0' - '9'3'0'0' - 9300K '1' - '8'0'0'0' - 8000K (default) '2' - '6'5'0'0' - 6500K '3' - 'U"S"E"R' - USER	Color temperature '0' - '9'3'0'0' - 9300K '1' - '8'0'0'0' - 8000K (default) '2' - '6'5'0'0' - 6500K '3' - 'U"S"E"R' - USER	Same as GEV2
Red Level for Selected Color Temperature	0xB4, nn '+' '-' 'r' 'R' '?'	Set Red Level = value / increment / decrement / reset / query	Red Gain Range=0'0'~2'5'5' Default = '1'2'8'	Red Gain Range=0'0'~2'5'5' Default = '1'2'8'	Same as GEV2
Green Level for Selected Color Temperature	0xB5, nn '+' '-' 'r' 'R' '?'	Set Green Level = value / increment / decrement / reset / query	Green Gain Range=0'0'~2'5'5' Default = '1'2'8'	Green Gain Range=0'0'~2'5'5' Default = '1'2'8'	Same as GEV2
Blue Level for Selected Color Temperature	0xB6, nn '+' '-' 'r' 'R' '?'	Set Blue Level = value / increment / decrement / reset / query	Blue Gain Range=0'0'~2'5'5' Default = '1'2'8'	Blue Gain Range=0'0'~2'5'5' Default = '1'2'8'	Same as GEV2
Graphic horizontal resolution enquiry	0xB7	Horizontal resolution (in pixels) in 3 digital hex number	'nnn' = horizontal resolution	'nnn' = horizontal resolution	Same as GEV2
Graphic vertical resolution enquiry	0xB8	Vertical resolution (in pixels) in 3 digital hex number	'nnn' = vertical resolution	'nnn' = vertical resolution	Same as GEV2
Graphic horizontal sync frequency	0xB9	Horizontal sync frequency (in units of 100Hz) in 3 digit hex number	'nnn' = horizontal frequency	'nnn' = horizontal frequency	Same as GEV2
Graphic vertical sync frequency	0xBA	Vertical sync frequency (in units of 0.1Hz) in 3 digit hex number and 1char	'nnnc' = vertical frequency c = 'i' or 'p' Interlace or progressive	'nnnc' = vertical frequency c = 'i' or 'p' Interlace or progressive	Same as GEV2
Set Address RS	0xBB, n '?	Set Address RS = value	Address RS Range -0'~'F'	Address RS Range -0'~'F'	Same as GEV2
Set IP address	0xBC, n.n.n.n 'a' 'A' '?	Set fix IP and IP = n.n.n.n (each n range is from '0' to '2'5'5') / Set auto IP, after send this command do AC on/off	'0' - fail '1' - success	'0' - fail '1' - success	Same as GEV2
Auto Position	0xC3	Auto set image position	'0' - fail '1' - success	'0' - fail '1' - success	Same as GEV2
Auto Color Balance	0xC5	Auto set image Color balance	'0' - fail '1' - success	'0' - fail '1' - success	Same as GEV2
Out Door mode	0xCA, '0' '1' 'R' 'r' '?'	Set the key is delay 5 second/ reset / query	'0' - OFF (default) '1' - ON	'0' - OFF (default) '1' - ON	Same as GEV2
Burn in	0xCC, '0' '1' 'R' 'r' '?'	Set burn in mode / reset / query	'0' - normal mode (default) '1' - burn in mode	'0' - normal mode (default) '1' - burn in mode	Same as GEV2
Test pattern	0xCD, '0' '1'	Display test pattern / Go to default state	'0' - normal display '1' - display built in test pattern	'0' - normal display '1' - display built in test pattern	Same as GEV2
OSD Factory Default	0xCE	Reset all parameters defined in OSD menu to default factory values	'0' - fail '1' - success	'0' - fail '1' - success	Same as GEV2

Serial/Ethernet/USB Communication (SCOM) Interface - MCC Commands

Function	Data	Description	VIC2	GEV2	Differences
Saving the user default	0xD7, n	Saving all parameter to user default value (n = '1' to '5' correspond to User1 to User5)	'0' - fail '1' - success	'0' - fail '1' - success	Same as GEV2
Loading the user default	0xD8, n	Loading all parameter to user default value (n = '1' to '5' correspond to User1 to User5, and '0' is read Default)	'0' - fail '1' - success	'0' - fail '1' - success	Same as GEV2
Swap Main & PIP	0xE3	Swap main and second source	N/A	'0' - fail '1' - success	Not supported for VIC2
Gamma reset	0xE5	Reset Gamma table value, after send this command do AC on/off	N/A	'0' - fail '1' - success	Not supported for VIC2
GDC Menu Button	0xF7	Physical button press equivalent	No Data: Single press+release 0x00: Press and hold 0xFF: Release	No Data: Single press+release 0x00: Press and hold 0xFF: Release	Same as GEV2
GDC '>' (down) Button	0xFA	Physical button press equivalent	No Data: Single press+release 0x00: Press and hold 0xFF: Release	No Data: Single press+release 0x00: Press and hold 0xFF: Release	Same as GEV2
GDC '<' (up) Button	0xFB	Physical button press equivalent	No Data: Single press+release 0x00: Press and hold 0xFF: Release	No Data: Single press+release 0x00: Press and hold 0xFF: Release	Same as GEV2
GDC '+' (right) Button	0xFC	Physical button press equivalent	No Data: Single press+release 0x00: Press and hold 0xFF: Release	No Data: Single press+release 0x00: Press and hold 0xFF: Release	Same as GEV2
GDC '-' (left) Button	0xFD	Physical button press equivalent	No Data: Single press+release 0x00: Press and hold 0xFF: Release	No Data: Single press+release 0x00: Press and hold 0xFF: Release	Same as GEV2
Power Plan - VGA buffer and USB in off mode	0x71, n 'r' 'R' '?'	*[1] - See comment	N/A	'0' - Disable '1' - Enable (Default)	only for GEV2.
Power Plan - LAN in off/sleep mode	0x72, n 'r' 'R' '?'	*[2] - See comment	N/A	'0' - Disabled '1' - Enabled (Default)	only for GEV2.

Serial/Ethernet/USB Communication (SCOM) Interface - MCC Commands

Function	Data	Description	VIC2	GEV2	Differences
Touch Power Mode	0x73, n 'r' 'R' '?'		0xFF - Always On 0xFE - Active Signal (Default) 0x00 - Always Off	0xFF - "Always Active" (Default) 0xFE - "Only active when unit is on and has a valid input signal" 0x00 - "Only active if selected source has a valid input signal" AND Selected Source= "Digital 1". 0x01 - "Only active if selected source has a valid input signal" AND Selected Source= "Digital 2". 0x10 - "Only active if selected source has a valid input signal" AND Selected Source= "Analog RGB1". 0x11 - "Only active if selected source has a valid input signal" AND Selected Source= "Analog RGB2". 0x20 - "Only active if selected source has a valid input signal" AND Selected Source= "Composite 1". 0x21 - "Only active if selected source has a valid input signal" AND Selected Source= "Composite 2". 0x22 - "Only active if selected source has a valid input signal" AND Selected Source= "Composite 3". 0x30 - "Only active if selected source has a valid input signal" AND Selected Source= "DisplayPort1".	Not possible to choose touch for the input signal, only always on/off or active signal.
External Power Button	0x74, n 'r' 'R' '?'	*[3] - See comment	'0' - Disabled (Default) '1' - Enabled	'0' - Disabled (Default) '1' - Enabled	Same as for GEV2
Picture Direction	0x75, n 'r' 'R' '?'		N/A	'0' - 0 degrees (default) '1' - 180 degrees	Only for GEV2
DDC / CI Settings	0x76, n 'r' 'R' '?'		'0' - Disabled, '1' - Enabled Default: '1'	0xFE - Disabled 0xFD - Active Main Source 0xFF - All Active Sources (default) 0x00 - Follow Digital 1 0x01 - Follow Digital 2 0x10 - Follow Analog RGB1 0x11 - Follow Analog RGB2 0x20 - Follow Composite 1 0x21 - Follow Composite 2 0x22 - Follow Composite 3 0x30 - Follow DisplayPort1	Different from GEV2

Serial/Ethernet/USB Communication (SCOM) Interface - MCC Commands

Function	Data	Description	VIC2	GEV2	Differences
GDC Button Sensitivity	0x78, nnn 'r' 'R' '?'		Range='0"0"0' ~ '2"5"5'	Range='0"0"0' ~ '2"5"5'	Same as for GEV2
DVI-I 1 Port Mode	0x7B, n 'r' 'R' '?'		N/A	'0' - Auto '1' - DVI-D '2' - DVI-A/VGA	Only for GEV2
DVI-I 2 Port Mode	0x7C, n 'r' 'R' '?'		N/A	'0' - Auto '1' - DVI-D '2' - DVI-A/VGA	Only for GEV2
RS Address (extended)	0x7D, n 0xFF,'r' 0xFF, 'R' 0xFF, '?'	*[4] - See comment	Range 0x00 ~ 0xFE Default: 0x00	Range 0x00 ~ 0xFE	Same as for GEV2
Stretch Horizontal	0x7E, nn 'r' 'R' '?'		N/A	Range='0"0' ~ '1"0"0' Default = '0"5'0'	Only for GEV2
Stretch Vertical	0x7F, nn 'r' 'R' '?'		N/A	Range='0"0' ~ '1"0"0' Default = '0"5'0'	Only for GEV2
Sleep Delay	0x61, nnn 'r' 'R' '?'		N/A	Range='0"0"0'~'0"6"0' Default = '0"0'0'	Only for GEV2 Firmware FW200001-0A01

Serial/Ethernet/USB Communication (SCOM) Interface - MCC Commands

Comments to MCC Command table

***[3] External Power button:**

The command is used to enable or disable the power ON/Off input on User interface.

***[4] RS Address (extended):**

The command is extended command Address configuration of RS485 configuration. It provides the same function as MCC 0xBB, but with two differences:

- Extended command MCC 0x7D is able to set address from 0x00 to 0xFE
- Extended command data byte in heximal format.

This command update the same data byte in EEPROM and OSD status package as MCC 0x7D.

Serial/Ethernet/USB Communication (SCOM) Interface

Operational Requirements

The following sections define the operational requirements.

Serial Message Failure

If serial messages stop being transmitted or are corrupt, the unit will remain at the last commanded brightness.

Periodic Messages

Commands shall be transmitted to the unit at a repetition no faster than 4 Hz.

Sending Multiple Commands / Command Queue

To ensure all commands are transmitted and executed successfully on the unit, a delay between each command in the queue shall be at least 500ms. Some internal commands require slightly longer to process internally in the unit, than others.

Keep-alive Alarm

The "SWI" query can be used for keep-alive alarm logic in the application software on the computer. It is recommended to limit this function to once a second (1000ms).

Individually Addressed Command Response Time

The unit will output the required response within $T_r = 2.5$ character periods after the last byte of a command message is received (2.6ms at 9600 bit/sec for Serial Mode only), except as specified herein.

Broadcast Command Response Time

In response to Serial mode RS-485 broadcast command messages, after the last byte of the command message is received, all units will reply within the time period defined for T_e , below. Further more, any gap between these individual responses will be less than the Intermessage Gap, defined below.

$$T_e = (T_r + L_r) * N, \text{ where}$$

L_r = length of the ACK/NAK message response
 T_r = response time
 N = the total number of units*

*) As the units reply in order to their address, the units must be given subsequent addresses, starting at zero, for N to equal the total number of units. If not, $N =$ the highest unit address + 1.

The maximum L_r for a selected command set are shown in the table below:

Command	BRT	BZZ	ETC	POT	SNB	SWI	SWK	TYP	MCC
L_r	9	9	11	9	13	19	11	28	xx**

***)This command will vary in size, and response time is longer. Make sure ACK is received from all units before sending a new command.

Example:

For the BRT command, and 8 units, this corresponds to $T_e = (2.5 * 10 + 9 * 10) * 8 / 9600 = 95.8$ ms

Intermessage Gap - Serial Mode

Following an individually addressed command, the next command shall not be issued until at least $T_g = 5$ character periods after the ACK or NAK message received. At 9600, that is $5 * 10 / 9600 = 5.2$ ms.

Following the issue of a broadcast command message, the next command shall not be issued until at least $T_c = T_e + T_g$, where T_e is as defined for Broadcast Command response and T_g is defined above.

Serial/Ethernet/USB Communication (SCOM) Interface

Unit Response and Addresses

When individual unit addressing is supported by an installed configuration of units in a RS-485 (for units that support it) system, a separate ACK or NAK message for each unit will be transmitted providing each unit's individual address in response to any broadcast addressed Command.

NAK messages will not be generated when an error in a Broadcast message is detected. When individual unit addressing is not supported, the unit will only respond to the broadcast address and will include the broadcast address in the ACK and NAK messages. NAK messages will not be generated when an error in a Broadcast message is detected.

When a unit receives an incomplete message and the next byte is not received until after a time equal to the Intermessage Gap, the next bytes received shall be processed to check for the start of a new command (0x07, ASCII Bell).

If the header checksum is valid, but the first byte of the command message is not 0x07, as specified, the unit may wait until after the next inter-message gap to resume checking. A NAK message shall not be generated.

If the header checksum is valid, but the value of the CMD field does not equal one of the defined commands, the unit shall reply by generating a NAK message as though a VER command had been received.

If the header checksum is valid, but the value of the LEN field is greater than the maximum allowed, the unit shall ignore the message. A NAK message shall not be generated.

If the data checksum is valid, but the value in the DATA field associated with a command is invalid (out of range, undefined, etc.), the unit shall generate a NAK message indicating the current data value in the DATA field.

Additional Commands

In time, additional commands and corresponding data fields may be defined. These additions will not conflict with the operation of the interface as defined herein in this document.

Calculating Checksums (IDCHK, IHCHK)

Here is a simplified method to calculating checksum. The example is using decimal numbers, for explanation purposes only. The actual values are in hexadecimal throughout the user manual.

Visual representation of the byte:

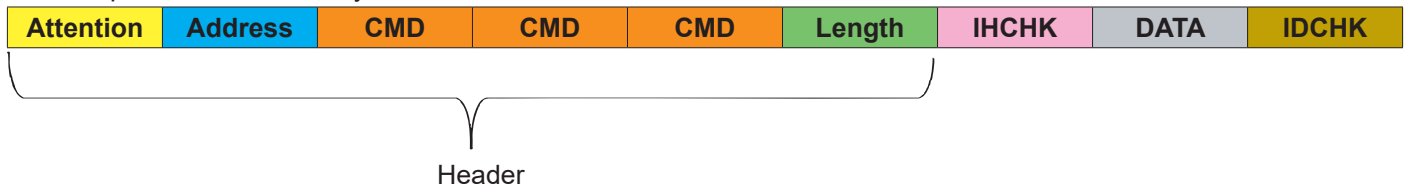

Number Base Systems mentioned in this section.

Binary	2^7	2^6	2^5	2^4	2^3	2^2	2^1	2^0
Decimal	128	64	16	16	8	4	2	1
Hex	80	40	20	10	8	4	2	1

The total value of a byte is represented by 8 bits, all bits have the value of either 0 or 1. One byte can represent a decimal number between 0 and 255 (256 different combinations).

For example: let us convert 55 from decimal to binary. We place in the table below (marked in green) 1 or 0 for the highest available decimal number in that cell and subtract until we reach 0.

So in the case of 55, it is: $55 - 32 - 16 - 4 - 2 - 1 = 0$

1 or 0	0	0	1	1	0	1	1	1
Binary	2^7	2^6	2^5	2^4	2^3	2^2	2^1	2^0
Decimal	128	64	32	16	8	4	2	1

This results in binary value 0011 0111 based on the input in the table, which in decimal are 55, and HEX 0x37.

IDCHK

Calculating IDCHK require us to find the inverted value of the sum of all data bits. We send a data package with the data value as 55, which we know is 0011 0111. The inverted data value is the inverted of 0011 0111 (55 converted to binary), which is 1100 1000.

If we then convert 1100 1000 to decimal using the conversion table above, we get 200
 In simpler terms, you could say we are doing $55 - 255 = -200$. Ignore the fact that it is a negative number.

Attention	Address	CMD	CMD	CMD	Length	IHCHK	55	200
-----------	---------	-----	-----	-----	--------	-------	----	-----

Calculating Checksums (IDCHK, IHCHK)

IDCHK with two data fields (2 bytes).

DATA1 DATA2 IDCHK

Calculating IDCHK while having two data fields (or more) is almost the same as single data field. Sum the two data fields, subtract 1 for every time you exceed 255 and start from 0.

Example of 2 data bytes:

Data field 1: 55 or as HEX 0x37
Data field 2: 230 or as HEX 0xE6

Add all the data fields together.
 $230 + 55 = 285$

Subtract 255 until the summed data value is below 255.
 $285 - 255 = 30$

Subtract 1 for every time subtracted 255 above.
 $30 - 1 = 29$

Subtract 29 based on decimal values from the binary table on previous page until you reach 0:
 $29 - 16 - 8 - 4 - 1 = 0$

Which gives us binary number (by using explanations on previous page).
0001 1101
inverted is (by using explanations on previous page).
1110 0010

Convert 1110 0010 to decimal is 226 or as HEX 0xE2

Attention	Address	CMD	CMD	CMD	Length	IHCHK	55	230	226
-----------	---------	-----	-----	-----	--------	-------	----	-----	-----

IDCHK with three data fields (3 bytes).

DATA1 DATA2 DATA3 IDCHK

Example using 3 data bytes:

Data field 1: 233 or as HEX 0xE9
Data field 2: 229 or as HEX 0xE5
Data field 3: 228 or as HEX 0xE4

Add all the data fields together.
 $233 + 229 + 228 = 690$

Subtract 255 until the summed data value is below 255.
 $690 - 255 = 435$
 $435 - 255 = 180$

Subtract 2 for every time subtracted 255 above.
 $180 - 2 = 178$

Subtract 178 based on decimal values from the binary table on previous page until you reach 0:
 $178 - 128 - 32 - 16 - 2 = 0$

Which gives us binary number (by using explanations on previous page).
1011 0010
inverted is (by using explanations on previous page).
0100 1101

Convert 0100 1101 to decimal is 77 or as HEX 0x4D

Attention	Address	CMD	CMD	CMD	Length	IHCHK	233	229	228	77
-----------	---------	-----	-----	-----	--------	-------	-----	-----	-----	----

Calculating Checksums (IDCHK, IHCHK)

IHCHK

Let us calculate IHCHK. We send the same data package, the data value does not matter for this calculation. Instead, we focus on the following formula that sums all the header values and inverts them. Note that DATA of **55** and IDCHK of **200** is present in table below as described on previous page. Length is set to 1 as there is only 1 byte in the DATA field.

Attention	Address	CMD	CMD	CMD	Length	IHCHK	Data	IDCHK
7	255	66	82	73	1	IHCHK	55	200

Add together as indicated below.

Attention field: **7** or as HEX **0x07**
 Address field: **255** or as HEX **0xFF**
 CMD 1 field: **66** or as HEX **0x42**
 CMD 2 field: **82** or as HEX **0x52**
 CMD 3 field: **73** or as HEX **0x49**
 Length field: **1** or as HEX **0x01** (Length of 1 indicates only 1 byte **55** is present in DATA field).

Add all the fields together.

$$7 + 255 + 66 + 82 + 73 + 1 = 484$$

Subtract 255 until the summed data value is below **255**.

$$484 - 255 = 229$$

Subtract 1 for every time subtracted **255** above.

$$229 - 1 = 228$$

Subtract 228 based on decimal values from the binary table (marked in green) until you reach 0:

$$228 - 128 - 64 - 32 - 4 = 0$$

1 or 0	1	1	1	0	0	1	0	0
Binary	2^7	2^6	2^5	2^4	2^3	2^2	2^1	2^0
Decimal	128	64	32	16	8	4	2	1

Which gives us binary number (by using explanations on previous page).

1110 0100

inverted is (by using explanations on previous page).

0001 1011

Convert 0001 1011 to decimal is **27** or as HEX **0x1B**

Attention	Address	CMD	CMD	CMD	Length	IHCHK	Data	IDCHK
7	255	66	82	73	1	27	55	200

HEX, ASCII, BIN and Character table

HEX	DEC	BIN	Character/Symbol	Description
0x00	0	00000000	NUL	Null terminator / character / End of string
0x01	1	00000001	SOH	Start of Heading
0x02	2	00000010	STX	Start of Text
0x03	3	00000011	ETX	End of Text
0x04	4	00000100	EOT	End of Transmission
0x05	5	00000101	ENQ	Enquiry
0x06	6	00000110	ACK	Acknowledgment
0x07	7	00000111	BEL	Bell
0x08	8	00001000	BS	Back Space
0x09	9	00001001	HT	Horizontal Tab
0x0A	10	00001010	LF	Line Feed
0x0B	11	00001011	VT	Vertical Tab
0x0C	12	00001100	FF	Form Feed
0x0D	13	00001101	CR	Carriage Return
0x0E	14	00001110	SO	Shift Out / X-On
0x0F	15	00001111	SI	Shift In / X-Off
0x10	16	00010000	DLE	Data Line Escape
0x11	17	00010001	DC1	Device Control 1 (oft. XON)
0x12	18	00010010	DC2	Device Control 2
0x13	19	00010011	DC3	Device Control 3 (oft. XOFF)
0x14	20	00010100	DC4	Device Control 4
0x15	21	00010101	NAK	Negative Acknowledgement
0x16	22	00010110	SYN	Synchronous Idle
0x17	23	00010111	ETB	End of Transmit Block
0x18	24	00011000	CAN	Cancel
0x19	25	00011001	EM	End of Medium
0x1A	26	00011010	SUB	Substitute
0x1B	27	00011011	ESC	Escape
0x1C	28	00011100	FS	File Separator
0x1D	29	00011101	GS	Group Separator
0x1E	30	00011110	RS	Record Separator
0x1F	31	00011111	US	Unit Separator
0x20	32	00100000		Space " "
0x21	33	00100001	!	Exclamation mark
0x22	34	00100010	"	Double quotes
0x23	35	00100011	#	Number
0x24	36	00100100	\$	Dollar
0x25	37	00100101	%	Percentage
0x26	38	00100110	&	Ampersand
0x27	39	00100111	'	Single quote
0x28	40	00101000	(Open parenthesis (or open bracket)
0x29	41	00101001)	Close parenthesis (or close bracket)
0x2A	42	00101010	*	Asterisk
0x2B	43	00101011	+	Plus
0x2C	44	00101100	,	Comma
0x2D	45	00101101	-	Minus / Hyphen
0x2E	46	00101110	.	Period, dot or full stop
0x2F	47	00101111	/	Slash or divide
0x30	48	00110000	0	Zero
0x31	49	00110001	1	One
0x32	50	00110010	2	Two

HEX, ASCII, BIN and Character table

HEX	DEC	BIN	Character/Symbol	Description
0x33	51	00110011	3	Three
0x34	52	00110100	4	Four
0x35	53	00110101	5	Five
0x36	54	00110110	6	Six
0x37	55	00110111	7	Seven
0x38	56	00111000	8	Eight
0x39	57	00111001	9	Nine
0x3A	58	00111010	:	Colon
0x3B	59	00111011	;	Semicolon
0x3C	60	00111100	<	Less than (or open angled bracket)
0x3D	61	00111101	=	Equals
0x3E	62	00111110	>	Greater than (or close angled bracket)
0x3F	63	00111111	?	Question mark
0x40	64	01000000	@	At symbol
0x41	65	01000001	A	Uppercase A
0x42	66	01000010	B	Uppercase B
0x43	67	01000011	C	Uppercase C
0x44	68	01000100	D	Uppercase D
0x45	69	01000101	E	Uppercase E
0x46	70	01000110	F	Uppercase F
0x47	71	01000111	G	Uppercase G
0x48	72	01001000	H	Uppercase H
0x49	73	01001001	I	Uppercase I
0x4A	74	01001010	J	Uppercase J
0x4B	75	01001011	K	Uppercase K
0x4C	76	01001100	L	Uppercase L
0x4D	77	01001101	M	Uppercase M
0x4E	78	01001110	N	Uppercase N
0x4F	79	01001111	O	Uppercase O
0x50	80	01010000	P	Uppercase P
0x51	81	01010001	Q	Uppercase Q
0x52	82	01010010	R	Uppercase R
0x53	83	01010011	S	Uppercase S
0x54	84	01010100	T	Uppercase T
0x55	85	01010101	U	Uppercase U
0x56	86	01010110	V	Uppercase V
0x57	87	01010111	W	Uppercase W
0x58	88	01011000	X	Uppercase X
0x59	89	01011001	Y	Uppercase Y
0x5A	90	01011010	Z	Uppercase Z
0x5B	91	01011011	[Opening bracket
0x5C	92	01011100	\	Backslash
0x5D	93	01011101]	Closing bracket
0x5E	94	01011110	^	Caret - circumflex
0x5F	95	01011111	_	Underscore
0x60	96	01100000	`	Grave accent
0x61	97	01100001	a	Lowercase a
0x62	98	01100010	b	Lowercase b
0x63	99	01100011	c	Lowercase c
0x64	100	01100100	d	Lowercase d
0x65	101	01100101	e	Lowercase e

HEX, ASCII, BIN and Character table

HEX	DEC	BIN	Character/Symbol	Description
0x66	102	01100110	f	Lowercase f
0x67	103	01100111	g	Lowercase g
0x68	104	01101000	h	Lowercase h
0x69	105	01101001	i	Lowercase i
0x6A	106	01101010	j	Lowercase j
0x6B	107	01101011	k	Lowercase k
0x6C	108	01101100	l	Lowercase l
0x6D	109	01101101	m	Lowercase m
0x6E	110	01101110	n	Lowercase n
0x6F	111	01101111	o	Lowercase o
0x70	112	01110000	p	Lowercase p
0x71	113	01110001	q	Lowercase q
0x72	114	01110010	r	Lowercase r
0x73	115	01110011	s	Lowercase s
0x74	116	01110100	t	Lowercase t
0x75	117	01110101	u	Lowercase u
0x76	118	01110110	v	Lowercase v
0x77	119	01110111	w	Lowercase w
0x78	120	01111000	x	Lowercase x
0x79	121	01111001	y	Lowercase y
0x7A	122	01111010	z	Lowercase z
0x7B	123	01111011	{	Opening brace
0x7C	124	01111100		Vertical bar
0x7D	125	01111101	}	Closing brace
0x7E	126	01111110	~	Equivalency sign - tilde
0x7F	127	01111111		Delete (no visible character)
0x80	128	10000000	€	Euro sign
0x81	129	10000001		(no visible character)
0x82	130	10000010	,	Single low-9 quotation mark
0x83	131	10000011	ƒ	Latin small letter f with hook
0x84	132	10000100	„	Double low-9 quotation mark
0x85	133	10000101	...	Horizontal ellipsis
0x86	134	10000110	†	Dagger
0x87	135	10000111	‡	Double dagger
0x88	136	10001000	^	Modifier letter circumflex accent
0x89	137	10001001	‰	Per mille sign
0x8A	138	10001010	Š	Latin capital letter S with caron
0x8B	139	10001011	‹	Single left-pointing angle quotation
0x8C	140	10001100	Œ	Latin capital ligature OE
0x8D	141	10001101		(no visible character)
0x8E	142	10001110	Ž	Latin captial letter Z with caron
0x8F	143	10001111		(no visible character)
0x90	144	10010000		(no visible character)
0x91	145	10010001	‘	Left single quotation mark
0x92	146	10010010	’	Right single quotation mark
0x93	147	10010011	“	Left double quotation mark
0x94	148	10010100	”	Right double quotation mark
0x95	149	10010101	•	Bullet
0x96	150	10010110	–	En dash
0x97	151	10010111	—	Em dash
0x98	152	10011000	˘	Small tilde

HEX, ASCII, BIN and Character table

HEX	DEC	BIN	Character/Symbol	Description
0x99	153	10011001	™	Trade mark sign
0x9A	154	10011010	š	Latin small letter S with caron
0x9B	155	10011011	›	Single right-pointing angle quotation mark
0x9C	156	10011100	œ	Latin small ligature oe
0x9D	157	10011101		(no visible character)
0x9E	158	10011110	ž	Latin small letter z with caron
0x9F	159	10011111	ÿ	Latin capital letter Y with diaeresis
0xA0	160	10100000		Non-breaking space (no visible character)
0xA1	161	10100001	¡	Inverted exclamation mark
0xA2	162	10100010	¢	Cent sign
0xA3	163	10100011	£	Pound sign
0xA4	164	10100100	¤	Currency sign
0xA5	165	10100101	¥	Yen sign
0xA6	166	10100110		Pipe, Broken vertical bar
0xA7	167	10100111	§	Section sign
0xA8	168	10101000	¨	Spacing diaeresis - umlaut
0xA9	169	10101001	©	Copyright sign
0xAA	170	10101010	ª	Feminine ordinal indicator
0xAB	171	10101011	«	Left double angle quotes
0xAC	172	10101100	¬	Not sign
0xAD	173	10101101		Soft hyphen
0xAE	174	10101110	®	Registered trade mark sign
0xAF	175	10101111	¯	Spacing macron - overline
0xB0	176	10110000	°	Degree sign
0xB1	177	10110001	±	Plus-or-minus sign
0xB2	178	10110010	²	Superscript two - squared
0xB3	179	10110011	³	Superscript three - cubed
0xB4	180	10110100	´	Acute accent - spacing acute
0xB5	181	10110101	µ	Micro sign
0xB6	182	10110110	¶	Pilcrow sign - paragraph sign
0xB7	183	10110111	·	Middle dot - Georgian comma
0xB8	184	10111000	¸	Spacing cedilla
0xB9	185	10111001	¹	Superscript one
0xBA	186	10111010	º	Masculine ordinal indicator
0xBB	187	10111011	»	Right double angle quotes
0xBC	188	10111100	¼	Fraction one quarter
0xBD	189	10111101	½	Fraction one half
0xBE	190	10111110	¾	Fraction three quarters
0xBF	191	10111111	¿	Inverted question mark
0xC0	192	11000000	À	Latin capital letter A with grave
0xC1	193	11000001	Á	Latin capital letter A with acute
0xC2	194	11000010	Â	Latin capital letter A with circumflex
0xC3	195	11000011	Ã	Latin capital letter A with tilde
0xC4	196	11000100	Ä	Latin capital letter A with diaeresis
0xC5	197	11000101	Å	Latin capital letter A with ring above
0xC6	198	11000110	Æ	Latin capital letter AE
0xC7	199	11000111	Ç	Latin capital letter C with cedilla
0xC8	200	11001000	È	Latin capital letter E with grave
0xC9	201	11001001	É	Latin capital letter E with acute
0xCA	202	11001010	Ê	Latin capital letter E with circumflex
0xCB	203	11001011	Ë	Latin capital letter E with diaeresis

HEX, ASCII, BIN and Character table

HEX	DEC	BIN	Character/Symbol	Description
0xCC	204	11001100	Ì	Latin capital letter I with grave
0xCD	205	11001101	Í	Latin capital letter I with acute
0xCE	206	11001110	Î	Latin capital letter I with circumflex
0xCF	207	11001111	Ï	Latin capital letter I with diaeresis
0xD0	208	11010000	Ð	Latin capital letter ETH
0xD1	209	11010001	Ñ	Latin capital letter N with tilde
0xD2	210	11010010	Ò	Latin capital letter O with grave
0xD3	211	11010011	Ó	Latin capital letter O with acute
0xD4	212	11010100	Ô	Latin capital letter O with circumflex
0xD5	213	11010101	Õ	Latin capital letter O with tilde
0xD6	214	11010110	Ö	Latin capital letter O with diaeresis
0xD7	215	11010111	×	Multiplication sign
0xD8	216	11011000	Ø	Latin capital letter O with slash
0xD9	217	11011001	Ù	Latin capital letter U with grave
0xDA	218	11011010	Ú	Latin capital letter U with acute
0xDB	219	11011011	Û	Latin capital letter U with circumflex
0xDC	220	11011100	Ü	Latin capital letter U with diaeresis
0xDD	221	11011101	Ý	Latin capital letter Y with acute
0xDE	222	11011110	Þ	Latin capital letter THORN
0xDF	223	11011111	ß	Latin small letter sharp s - ess-zed
0xE0	224	11100000	à	Latin small letter a with grave
0xE1	225	11100001	á	Latin small letter a with acute
0xE2	226	11100010	â	Latin small letter a with circumflex
0xE3	227	11100011	ã	Latin small letter a with tilde
0xE4	228	11100100	ä	Latin small letter a with diaeresis
0xE5	229	11100101	å	Latin small letter a with ring above
0xE6	230	11100110	æ	Latin small letter ae
0xE7	231	11100111	ç	Latin small letter c with cedilla
0xE8	232	11101000	è	Latin small letter e with grave
0xE9	233	11101001	é	Latin small letter e with acute
0xEA	234	11101010	ê	Latin small letter e with circumflex
0xEB	235	11101011	ë	Latin small letter e with diaeresis
0xEC	236	11101100	ì	Latin small letter i with grave
0xED	237	11101101	í	Latin small letter i with acute
0xEE	238	11101110	î	Latin small letter i with circumflex
0xEF	239	11101111	ï	Latin small letter i with diaeresis
0xF0	240	11110000	ð	Latin small letter eth
0xF1	241	11110001	ñ	Latin small letter n with tilde
0xF2	242	11110010	ò	Latin small letter o with grave
0xF3	243	11110011	ó	Latin small letter o with acute
0xF4	244	11110100	ô	Latin small letter o with circumflex
0xF5	245	11110101	õ	Latin small letter o with tilde
0xF6	246	11110110	ö	Latin small letter o with diaeresis
0xF7	247	11110111	÷	Division sign
0xF8	248	11111000	ø	Latin small letter o with slash
0xF9	249	11111001	ù	Latin small letter u with grave
0xFA	250	11111010	ú	Latin small letter u with acute
0xFB	251	11111011	û	Latin small letter u with circumflex
0xFC	252	11111100	ü	Latin small letter u with diaeresis
0xFD	253	11111101	ý	Latin small letter y with acute
0xFE	254	11111110	þ	Latin small letter thorn
0xFF	255	11111111	ÿ	Latin small letter y with diaeresis

C# / Pseudo Ethernet/TCP Code example

```
{
    // Create SCOM package
    byte[] cmd = enc.GetBytes("BRT");
    byte[] data = new byte[1] { 0x99 }; // 60% brightness
    COMMessage message = new COMMessage(cmd, data);

    // Transmitting SCOM package to TCP
    SendTCPCommand(message);
}

private Byte[] SendTCPCommand(COMMessage commessage)
{
    // Creating new TCPClient
    TcpClient tcpClient = new TcpClient();

    // Byte version of the SCOM package
    byte[] byteMessage = (byte[])commessage.Message.ToArray(typeof(byte));

    //Display IP adresse
    IPAddress displayAddr = IPAddress.Parse(DisplayIPAddress);
    Int32 port = 10001; //constant

    //Connecting
    tcpClient.Connect(displayAddr, port);

    // Create a stream from TCPClient
    NetworkStream stream = tcpClient.GetStream();

    //write the SCOM package into stream
    stream.Write(byteMessage, 0, byteMessage.Length);

    // wait for response
    Thread.Sleep(GlobalwaitTime);

    // Read Response
    // To be compliant with SCOM package (ATTN, ADDR, CMD, CMD, CMD, LEN, IHCHK, DATA, IDCHK)
    stream.Read(data, 0, data.Length);
}
```

Operation Advanced (DDC/CI) Control Overview

Introduction

DDC/CI (Display Data Channel/Command Interface) specifies a means for a computer to send commands to the unit's Display Video Controller to programmatically adjust parameters of the display instead of pressing physical buttons or navigate through an OSD menu. Specific commands to control units are defined in a separate official Monitor Control Command Set (MCCS) industry standard. The signal inputs supported are DVI*, HDMI, DisplayPort (DP) and VGA*.

To determine if your unit has the DDC/CI commands supported as described in this chapter, please review the "On Screen Display (OSD) Menu" chapter (Service section) in this manual.

It is expected that the user has previous experience of the DDC/CI protocol and how to implement the commands in their own control applications. A suitable starting point for sending commands, are the GUI operated (or command line version) of softMCCS software, reference: <http://www.entechtaiwan.com/lib/softmccs.shtm>

The listed DDC/CI commands below are equivalent to the same functions available in the well implemented Hatteland Technology Serial/Ethernet Communication Control Interface (SCOM) protocol, where specified, reference: <https://www.hattelandtechnology.com/hubfs/pdfget/inb100018-6.htm>

The column "SCOM" is a reference and not part of the DDC/CI commands explained in the table below.

*NOTE: This chapter is an overall description of DDC/CI support for various/selected Hatteland Technology products. References to VGA (RGB), DVI and Composite may not be present on your product, due to hardware changes/Engineering Change Notifications issued for Multi Vision Displays (MVD), please check actual datasheet for your model to verify.
Reference: <https://www.hattelandtechnology.com/product-notifications/hardware-change-/upgrade-for-32inch-and-55inch-products>

Syntax: [S] = Start Condition & [P] = Stop Condition (marked with gray color). Numbers in black/green/red colors are Byte Value in Hexadecimal.

Description	Syntax and Functionality	Details and Values	Via SCOM
User Brightness Control (backlight) (0x10)	Set/Write Brightness value: [S] <6E:w> 51 84 03 10 00 xx FD [P] Reply of successful request: [S] <6F:r> FD 80 BE* [P] Read Brightness value: [S] <6E:w> 51 82 01 10 AC [P] Reply of successful request: [S] <6F:r> 6E 88 02 00 10 00 00 FF 00 xx 95* [P]	10 = Command ID Where xx = 0 to 255 Min-Max Range: 0-255 (0x00-0xFF) During Read reply, these values will be present. Read/Write support.	BRT
Power Mode (Power On/Off/Sleep) (0xD6) *Note: Not the same as OSD's "Power Plan" function.	Write Power Mode: [S] <6E:w> 51 84 03 D6 00 xx 5C [P] Reply of successful request: [S] <6F:r> 5C 80 BE* [P] Read Power Mode: [S] <6E:w> 51 82 01 D6 6A [P] Reply of successful request: [S] <6F:r> 6E 88 02 00 D6 01 00 05 00 xx 67* [P]	D6 = Command ID Where xx is: 0x01 = On 0x02 = Standby 0x03 = Standby 0x04 = Standby 0x05 = OFF 0x3F = Read Command: Modes are described in INB100018-6 (SCOM) document. Read/Write support.	PWR
Glass Display Control™ (GDC) Brilliance Button (0xE2)	Set/Write Brilliance value: [S] <6E:w> 51 84 03 E2 00 xx 68 [P] Reply of successful request: [S] <6F:r> 68 80 BE* [P] Read Brilliance value: [S] <6E:w> 51 82 01 E2 5E [P] Reply of successful request: [S] <6F:r> 6E 88 02 00 E2 00 00 FF 00 xx 00* [P]	E2 = Command ID Where xx = 0 to 255 Min-Max Range: 0-255 (0x00-0xFF) During Read reply, these values will be present. Read/Write support.	BRU

Operation Advanced (DDC/CI) Control Overview

Description	Syntax and Functionality	Details and Values	Via SCOM
Color Mode: Kelvin Color Temperature (0x14)	Set/Write Color Temperature: [S] <6E:w> 51 84 03 14 00 ww xx [P] Reply of successful request: [S] <6F:r> xx 80 BE* [P] Read Color Temperature Value: [S] <6E:w> 51 82 01 14 A8 [P] Reply of successful request: [S] <6F:r> 6E 88 02 00 14 00 00 0E 00 yy zz* [P]	14 = Command ID Where Write ww xx 05 A9 = 6500 07 AB = 8000 08 A4 = 9300 Where Read yy zz 05 AB = 6500 07 A9 = 8000 08 A6 = 9300 Read/Write support.	MCC: (Color Temperature Select)
Gamma Calibration (0x14)	Set/Write Calibration: [S] <6E:w> 51 84 03 14 00 ww xx [P] Reply of successful request: [S] <6F:r> xx 80 BE* [P] Read Calibration: [S] <6E:w> 51 82 01 14 A8 [P] Reply of successful request: [S] <6F:r> 6E 88 02 00 14 00 00 0E 00 yy zz* [P]	14 = Command ID Where Write ww xx 0C A0 = VGA* 0D A1 = DVI* 0E A2 = DP 0F A3 = HDMI Where Read yy zz 0C A2 = VGA* 0D A3 = DVI* 0E A4 = DP 0F A5 = HDMI Read/Write support.	MCC: (Gamma Calibration))
Buzzer Control (0xE5) Note: May not be available on all models, please review specific datasheet if "Buzzer" is available.	Write/Turn ON: [S] <6E:w> 51 84 03 E5 00 FF 5C [P] Reply of successful request: [S] <6F:r> 5C 80 BE* [P] Write/Turn OFF: [S] <6E:w> 51 84 03 E5 00 00 5D [P] Reply of successful Turn OFF request: [S] <6F:r> 5D 80 BE* [P]	E5 = Command ID Where FF = Turn On Where 00 = Turn Off Write Support only.	BZZ

Operation Advanced (DDC/CI) Control Overview

Description	Syntax and Functionality	Details and Values	Via SCOM
Touch Power Mode (0xE6)	<p>Write/Set Power Mode: [S] <6E:w> 51 84 03 E6 00 xx A1 [P] Reply of successful request: [S] <6F:r> 5C 80 BE*[P]</p> <p>Read Power Mode: [S] <6E:w> 51 82 01 E6 5A [P] Reply of successful request : [S] <6F:r> 6E 88 02 00 E6 01 00 FF 00 FF 53*[P]</p>	<p>E6 = Command ID Where xx is:</p> <p>0xFF = Always Active 0xFE = Only active when display is on and has an active input signal 0x00 = Touch Off</p> <p>Read/Write support.</p>	MCC: (Touch Power Mode)
Actual Temperature (0xF0)	<p>Read Temperature: [S] <6E:w> 51 82 01 F0 4C [P] Reply of successful request: [S] <6F:r> 6E 88 02 00 F0 01 ww xx yy zz 63*[P]</p>	<p>F0 = Command ID</p> <p>Read support.</p> <p>Reply 4 bytes (ww, xx, yy, zz) indicating degree in Celcius. Example: 0038</p>	TMP
Unit Run Time (0xF3)	<p>Read Elapsed Hours: [S] <6E:w> 51 82 01 F3 4F [P] Reply of successful request: [S] <6F:r> 6E 88 02 00 F3 01 ww xx yy zz 63*[P]</p>	<p>F3 = Command ID</p> <p>Read support.</p> <p>Reply in ASCII 4 bytes (ww, xx, yy, zz) indicating hours. Example: 1038</p>	ETC



IEC62368 policy for Hatteland Technology products

Introduction





According to the requirements of EN 62368-1:2014.

The tables below refers to the policies for opening, servicing and installation of the unit(s) referred to in this manual. This equipment is designed to be used as a fixed installation and to be sold through special sales channels for professional use.

Based on requirements EN 62368-1:2014 and IEC 62368-1:2018

Defenition	Description
Ordinary person/ Sailor/End-User 	Ordinary person is the term applied to all persons other than instructed persons and skilled persons. Ordinary persons include not only users of the equipment, but also all persons who may have access to the equipment or who may be in the vicinity of the equipment. Under normal operating conditions or abnormal operating conditions, ordinary persons should not be exposed to parts comprising energy sources capable of causing pain or injury. Under a single fault condition, ordinary persons should not be exposed to parts comprising energy sources capable of causing injury.
Instructed person 	Instructed person is a term applied to persons who have been instructed and trained by a skilled person, or who are supervised by a skilled person, to identify energy sources that may cause pain and to take precautions to avoid unintentional contact with or exposure to those energy sources. Under normal operating conditions, abnormal operating conditions or single fault conditions, instructed persons should not be exposed to parts comprising energy sources capable of causing injury.
Skilled person 	Skilled person is a term applied to persons who have training or experience in the equipment technology, particularly in knowing the various energies and energy magnitudes used in the equipment. Skilled persons are expected to use their training and experience to recognize energy sources capable of causing pain or injury and to take action for protection from injury from those energies. Skilled persons should also be protected against unintentional contact or exposure to energy sources capable of causing injury.

IEC62368 policy for Hatteland Technology products

Authority	Description
Children 	This equipment is not suitable for use in locations where children are likely to be present.
Ordinary person/ Sailor/End-User 	Not allowed to open unit. Not allowed to install the unit. Not allowed to terminate/connect cables to the unit.
Instructed person 	Allowed to open hatches/latches which does not require tools, such as Disktrays. Allowed to open "battery-hatch" to change the battery even if tools are required. Allowed to install the unit. Allowed to terminate/connect cables to the unit indoors.
Skilled person 	Allowed to open and disassemble the unit. Allowed to install the unit. Allowed to terminate/connect cables to the unit indoors and outdoors. Allowed to terminate/connect earth/ground wire. Note: Be aware that additional definition for "skilled person" may apply, country dependent.

Conditions	Description
AC power net Class	Class 1. Pollution degree 2. Over voltage category 2.
Transient requirement	External circuits are considered to be installed wholly within the same building structure.
Battery	Obligated to use battery specified for the product.
Altitude	Products are designed for a max operating altitude of 2000m.

Installation	Description
Mounting brackets	Only bracket defined/specified for the unit is allowed.
AC power cord	When installed it shall be possible to disconnect the unit from the AC power net i.e. possible to reach AC connector.
Transient requirement	External circuits are considered to be installed wholly within the same building structure.
Earthing	Obligated to use defined earthing material/method specified for the unit. Minimum protective bonding conductor size of copper conductors: Wire: Minimum 1,5mm ² but Hatteland Technology recommends 2,5mm ² (AWG12) marked yellow/green.
Outdoor	Units with IP66/67-rated fronts can be used in outside environments, provided that the console they are fitted in fulfil certain requirements. <ul style="list-style-type: none"> - There must be a fully water/dustproof seal between the IP66 front and the console. - Dust/water ingress protection of console. (Unit/product is rated for pollution degree 2). - Humidity/condensation control in console. - Thermal management in console (so units can operate within rated temperature range). Units with IP20/IP22 shall not be used outdoor.
Outdoor Installation	Appropriate RCD with ground current rating of 20mA or less shall be used.

Basic Trouble-shooting

GENERAL ISSUES FOR TFT PANEL BASED PRODUCTS

Note: Applies for a range of various products. This is only meant as a general guide.

NO PICTURE / LED BEHAVIOUR:

If there is no light at all in the LED at the FRONT, check power cables. If the LED in front is green, then check if the brightness is set/adjusted to max brightness. Lack of image is most likely to be caused by incorrect connection, lack of power or wrong BIOS settings.

SCROLLING / UNSTABLE IMAGE:

Signal cable may not be completely connected to computer or TFT display. Check the pin assignments and signal timings of the display and your video card with respect to recommended timing and pin assignments. Make sure that the video card is compatible and that it is properly seated / installed on the computer.

DISPLAY AREA IS NOT CENTERED / SIZED CORRECTLY

Make sure that a supported video mode has been selected on the display, or on the video card / system. If it is impossible to position the image correctly, i.e. the image adjustment controls will not move the image far enough, then test it again using another graphics card for the PC system. This situation may occur with a custom graphics card that is not close to standard timings or if something is in the graphics line that may be affecting the signal, such as a signal splitter (please note that normally a signal splitter will not have any adverse effect). If it is impossible to change to the correct resolution/color depth, check if you have the right graphics driver installed in your system.

IMAGE APPEARANCE:

A faulty TFT panel can have black lines, pixel errors, failed sections, flickering or flashing image. Incorrect graphic card refresh rate, resolution or interlaced mode will probably cause the image to be the wrong size, it may scroll, flicker badly or possibly even no image is present. Sparkling on the display may be a faulty TFT panel signal cable, and it needs service attention.

VGA Signal Only: Horizontal interference can usually be corrected by adjusting the PHASE (OSD menu).
Vertical interference can usually be corrected by adjusting the FREQUENCY (OSD menu).

DEW CONDENSATION BEHIND GLASS:

Note that this problem will not occur on bonded products. For non-bonded products, do the following:
Power on the TFT product and set brightness to 100%. Turn off any automatic screensavers on PC or similar. During minutes the dew will be gone. To speed up the process, use a fan heater for a reasonable time. Do not overheat the unit.

Parts in Displays and Panel Computers, and how to recycle

Part	Where to dispose of parts	
TFT Panel	Electrical waste	Optically bonded units: the TFT Panel, Glass and frame is to be disposed of as Electrical waste. Do not separate.
Glass	Metal waste	
Frame	Metal waste	
Chassis	Metal waste	
Brackets	Metal waste	
Motherboard / Electronic Boards (PCB's)	Electrical waste	
Power supply	Electrical waste	
Cable Kit	Electrical waste	
Outerbox, sleeve and Kit box	Paper waste	
Paper sheets/User Manual	Paper waste	
Plastic bags	Plastic waste	
EPS Foam	Plastic waste	

Contact Hatteland Technology for specific part numbers: <https://www.hattelandtechnology.com/spareparts>

Dismantling of Displays and Panel Computers into its recyclable parts

To be able to dispose of the unit in the correct manner, Hatteland Technology bases its requirements on *Commissioning Regulation (EU) 2019/2021*. For more instructions concerned to the dismantling procedure, please contact Hatteland Technology. Reference online: <https://www.hattelandtechnology.com/parts-and-recycling>



Step 1. Separate the electronics from any metal and glass that is easily separatable.
If unit is optically bonded, do not separate TFT panel from glass and Metal frame (glass, TFT panel and Metal Frame is to be disposed of as if electronic waste if Optically Bonded).

Step 2. Sort the source materials and dispose of the electronics and metal/glass parts in the appropriate recycling/sorting station.

Spare Parts for Panel Computers (none for Displays)

Parts that require scheduled checks and replacement:

Part	Applicable for
SSD	Panel Computers
BIOS Battery	Panel Computers
Air filter	Panel Computers

Contact Hatteland Technology for specific part numbers: <https://www.hattelandtechnology.com/spareparts>

Service Parts for Displays and Panel Computers

Parts that needs to be replaced in case of failure:

Part	Applicable for
CPU	Panel Computers
RAM	Panel Computers
Power Supply	Displays and Panel Computers
SSD	Panel Computers
CPU FAN/Cooler	Panel Computers
System fans	Displays and Panel Computers
Video Controller	Displays

Contact Hatteland Technology for specific part numbers: <https://www.hattelandtechnology.com/spareparts>

Contact Hatteland Technology for availability of Firmware and Software updates: <https://www.hattelandtechnology.com/support/contact>

Notes

General Notes:

- The unit is tested according to IEC 60945 4th (EN 60945:2002), 4.4, equipment category b) “protected from the weather (formerly class B)”.
- Other type approvals applies for the different products.
Please see the appropriate “Specifications” page in this manual for more information.
- Use of brilliance and Glass Display Control™ (touch key functions) may inhibit visibility of information at night.

2-pin Terminal Block 5.08 - DC Power Input



All pinout assignments are seen from users Point of View (POV) while looking straight at the connector.

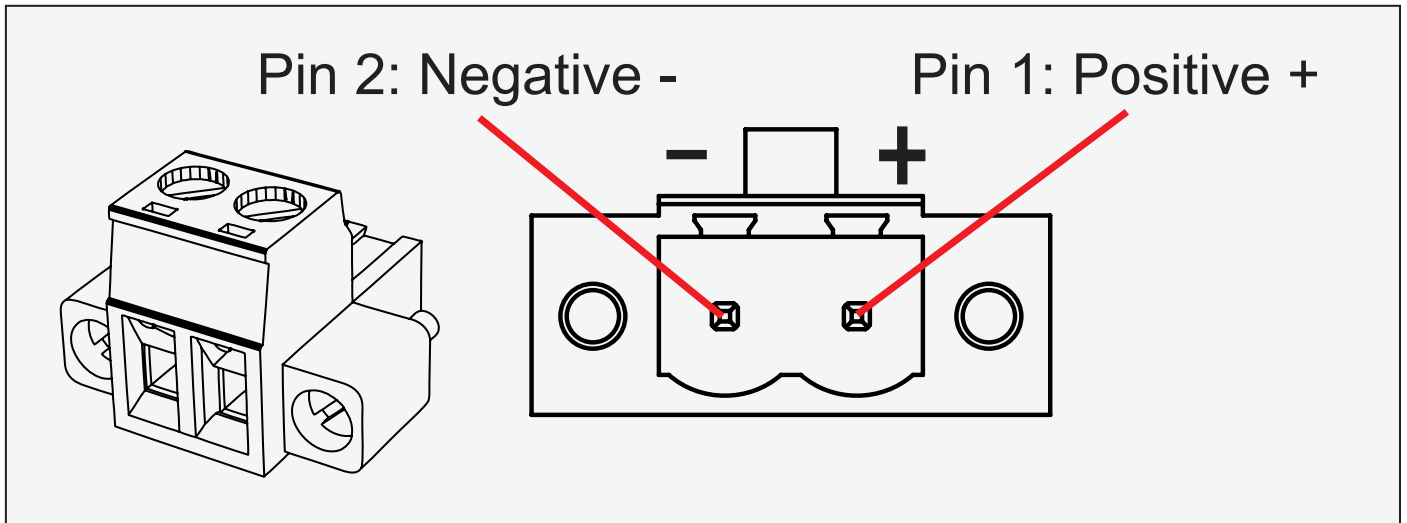

Grounding Screw



All pinout assignments are seen from users Point of View (POV) while looking straight at the connector.



Pan head screw M4x8mm w/spring and plainwasher

9-pin Serial COM RS-232+Buzzer non-isolated, DSUB Male



All pinout assignments are seen from users Point of View (POV) while looking straight at the connector.

RS232-Wake On Ring is not enabled.

Buzzer - External Drive Logic:

- Able to supply 12VDC+-5%@100mA
- Short circuit protected at <500mA
- <50VDC from ground of Display unit (Our input is isolated, this is layout limitation)
- Our input is classified as signal input, not power.

Series X (G1 - Generation 1):

- External drive logic can drive the buzzer even when the Display Unit is off.

Series X (G2 - Generation 2) / MVD Series:

- Display Unit needs external power connected to turn buzzer on. (Any logic power state).

Notes:

Unit may have several physical connectors available for Buzzer control. Please only use RS-232 or RS-485 pins to control Buzzer, not both at the same time.

Note: Requires soldering and assembly. It is expected that the technician has experience in electronics, soldering and assembling cables and connectors. Use a cable that contains at least 2 wires (not 2 single wires). Heat Shrink Tubes must be applied to soldered wire/pins. Test connection (beep) with Voltage Meter. Wires may be combined if using RS-232 COM as well.

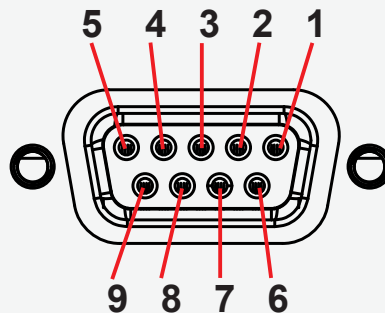

PIN 01	BUZ+	Buzzer Control Positive IN
PIN 02	TxD	Transmit Data
PIN 03	RxD	Receive Data
PIN 04	DTR	Data Terminal Ready
PIN 05	GND	Ground
PIN 06	DSR	Data Set Ready
PIN 07	RTS	Request To Send
PIN 08	CTS	Clear To Send
PIN 09	BUZ-	Buzzer Control Negative IN



All pinout assignments are seen from users Point of View (POV) while looking straight at the connector.

Suggested "Buzzer" Control Logic inside Computer/System:

Internal Side

External Side

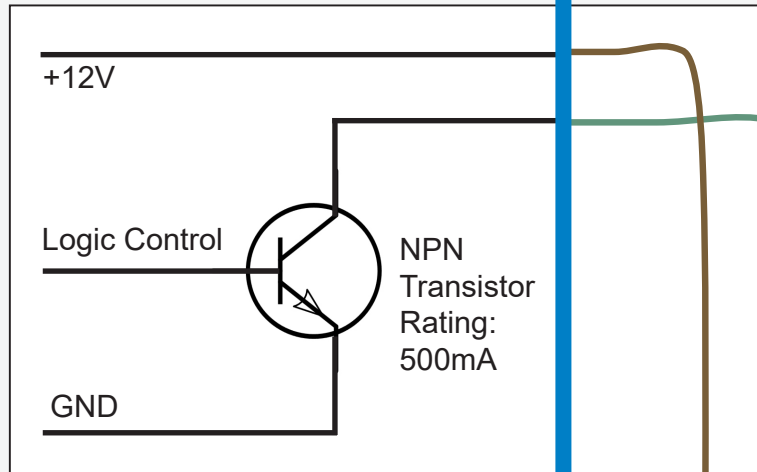

Pin 1 on your Connector

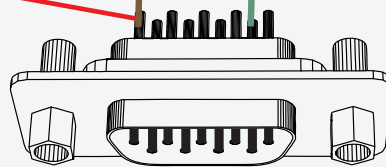

Pin 1

Pin 9

9-pin DSUB Male

Note Orientation!

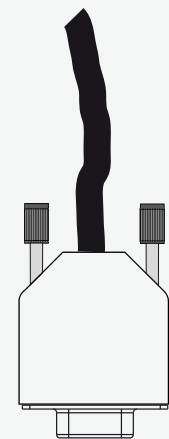

Add
Back Shell

20-pin DisplayPort (DP) Female



All pinout assignments are seen from users Point of View (POV) while looking straight at the connector.

Pins 13 and 14 may either be directly connected to ground or connected to ground through a pulldown device. This is the pinout for source-side connector, the sink-side connector pinout will have lanes 0–3 reversed in order; i.e., lane 3 will be on pin 1(n) and 3(p) while lane 0 will be on pin 10(n) and 12(p).

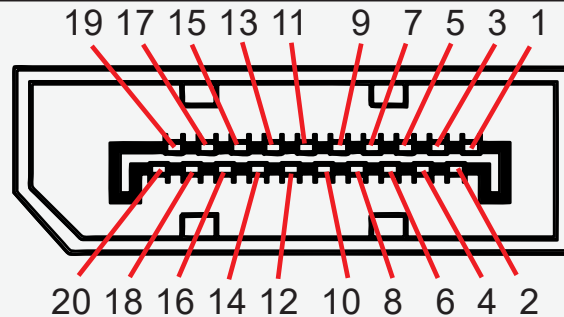

PIN 01	ML_Lane 0 (p) - Lane 0 (positive)
PIN 02	GND - Ground
PIN 03	ML_Lane 0 (n) - Lane 0 (negative)
PIN 04	ML_Lane 1 (p) - Lane 1 (positive)
PIN 05	GND - Ground
PIN 06	ML_Lane 1 (n) - Lane 1 (negative)
PIN 07	ML_Lane 2 (p) - Lane 2 (positive)
PIN 08	GND - Ground
PIN 09	ML_Lane 2 (n) - Lane 2 (negative)
PIN 10	ML_Lane 3 (p) - Lane 3 (positive)
PIN 11	GND - Ground
PIN 12	ML_Lane 3 (n) - Lane 3 (negative)
PIN 13	CONFIG1 - connected to Ground
PIN 14	CONFIG2 - connected to Ground
PIN 15	AUX CH (p) - Auxiliary Channel (positive)
PIN 16	GND - Ground
PIN 17	AUX CH (n) - Auxiliary Channel (negative)
PIN 18	Hot Plug - Hot Plug Detect
PIN 19	Return - Return for Power
PIN 20	DP_PWR - Power for connector (3.3 V 500 mA)

19-pin HDMI Female



All pinout assignments are seen from users Point of View (POV) while looking straight at the connector.

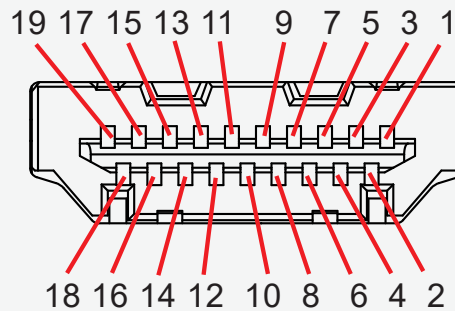

PIN 01	TMDS Data2+
PIN 02	TMDS Data2 Shield
PIN 03	TMDS Data2-
PIN 04	TMDS Data1+
PIN 05	TMDS Data1 Shield
PIN 06	TMDS Data1-
PIN 07	TMDS Data0+
PIN 08	TMDS Data0 Shield
PIN 09	TMDS Data0-
PIN 10	TMDS Clock+
PIN 11	TMDS Clock Shield
PIN 12	TMDS Clock-
PIN 13	CEC
	Reserved (HDMI 1.0–1.3a)
PIN 14	Utility/HEAC+ (HDMI 1.4+, optional, HDMI Ethernet Channel and Audio Return Channel)
PIN 15	SCL (I ² C Serial Clock for DDC)
PIN 16	SDA (I ² C Serial Data for DDC)
PIN 17	Ground (for DDC, CEC, ARC and HEC)
PIN 18	+5 V (min. 0.055 A)
	Hot Plug Detect (all versions)
PIN 19	HEAC- (HDMI 1.4+, optional, HDMI Ethernet Channel and Audio Return Channel)

9-pin User Interface, DSUB Male



All pinout assignments are seen from users Point of View (POV) while looking straight at the connector.

- External Potentiometer
- External Push Button On/Off
- External Push Button - Dimming
- +5V DC
- +12V DC

Warning: Do not connect or disconnect cables/connectors to this connector while the Display unit is powered on. Failure to do so may result in damaged electronics inside the Display Unit. A short on wires may cause system to restart.

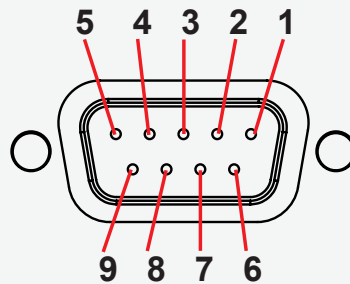

PIN 01	+5V	+5V out - Max 0.5A
PIN 02	PWR	Power On / Off
PIN 03	Res.	Reserved, do not connect
PIN 04	Aref	For potentiometer
PIN 05	+12V	+12V out - Max 0.5A
PIN 06	BRT_POT	Potentiometer in
PIN 07	BRT -	Button in
PIN 08	BRT+	Button in
PIN 09	GND	Ground

9-pin User Interface, DSUB Male



All pinout assignments are seen from users Point of View (POV) while looking straight at the connector.

User-Potentiometer Control: Potentiometer shall be **10kΩ LINEAR**. Connect like the illustrations shown below:

Building your own cable: **Note:** Requires soldering and assembly. It is expected that the technician has experience in electronics, soldering and assembling cables and connectors.

Use a cable that contains at least 3 wires (not 3 single wires). Heat Shrink Tubes must be applied to soldered wire/pins. Test connection (beep) with Voltage Meter. Test connection between power pin and other pins to ensure no short circuit is present prior to connecting cable and power on Display unit. Finally, the 9-pin DSUB must be covered by a back shell.

In order to activate the external Potentiometer control, the internal *“POT” - Backlight Control Interface selection* command has to be set first via our SCOM (Serial Communication Control Interface).

Usage for SCOM: Review the dedicated Technical Manual available from our website:
<https://www.hattelandtechnology.com/hubfs/pdfget/inb100018-6.htm>

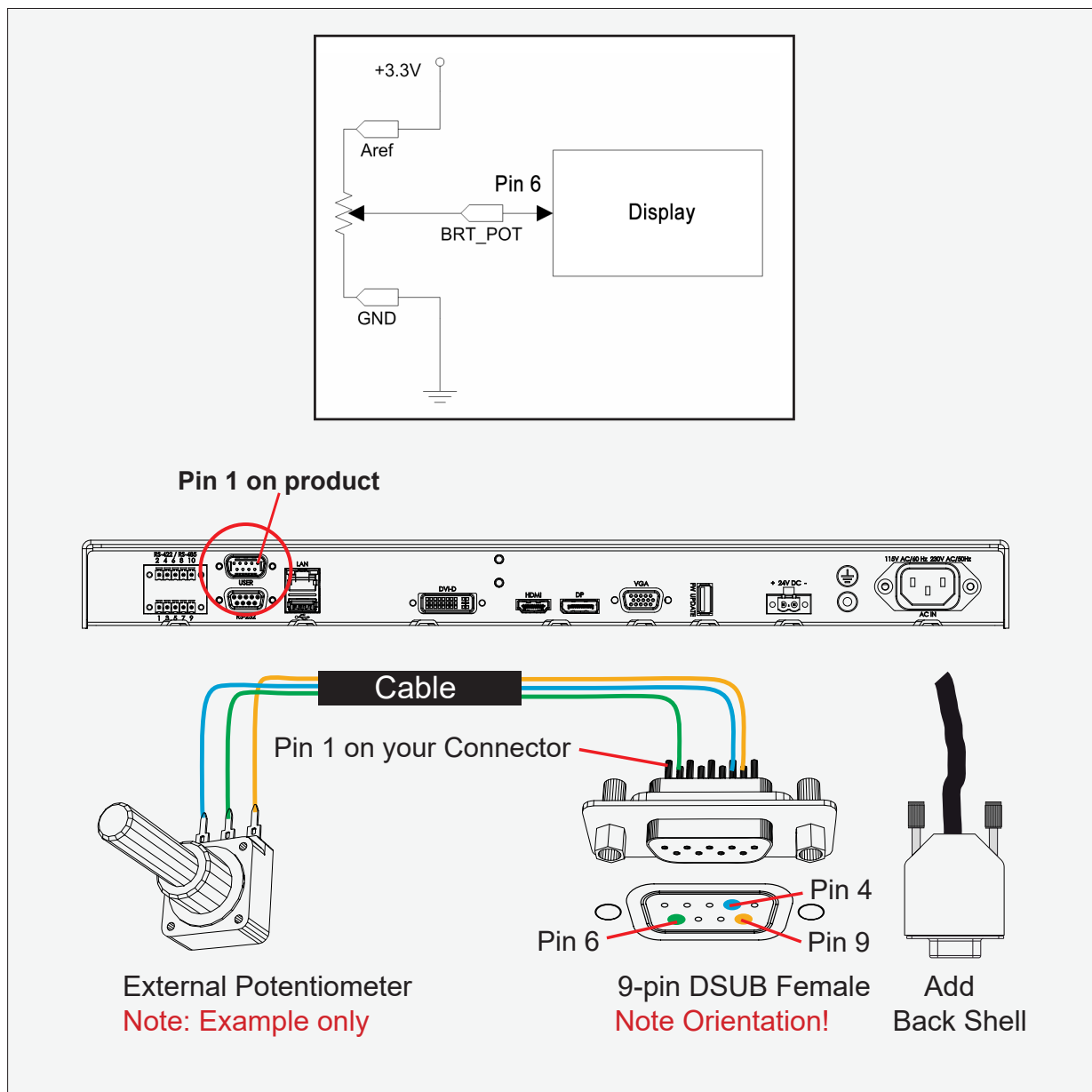

9-pin User Interface, DSUB Male



All pinout assignments are seen from users Point of View (POV) while looking straight at the connector.

User-External Power ON/OFF Control:

External Power Button must be of "Push Button" type. Instant-On. To turn off unit, Press & Hold down for 3 seconds.

Building your own Push Button for External Power Button:

Note: Requires soldering and assembly. It is expected that the technician has experience in electronics, soldering and assembling cables and connectors.

Use a cable that contains at least 2 wires (not 2 single wires). Heat Shrink Tubes must be applied to soldered wire/pins. Test connection (beep) with Voltage Meter.

In order to activate the external Power ON/OFF control it must be enabled:

Via OSD Menu: "OSD Miscellaneous>External Power Button" and set to Enable or Via SCOM (Serial Communication Control Interface): "MCC" - OSD Control Functionality -> "External Power Button (0x74)".

Usage for SCOM: Review the dedicated Technical Manual available from our website: <https://www.hattelandtechnology.com/hubfs/pdfget/inb100018-6.htm>

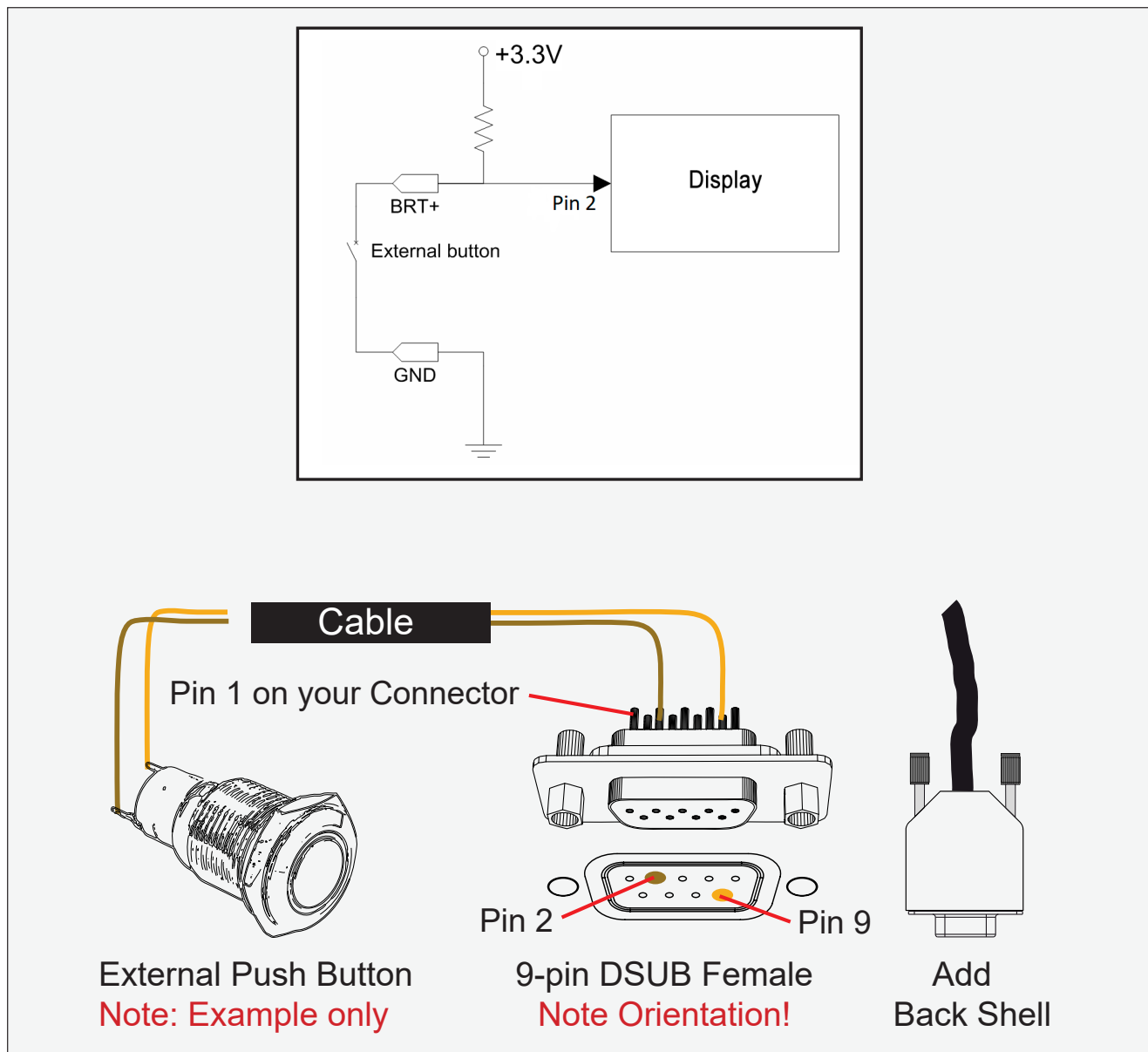

9-pin User Interface, DSUB Male



All pinout assignments are seen from users Point of View (POV) while looking straight at the connector.

USER-External dimming: External dimming buttons must be of “Push Button” type. Push or push and hold down for dimming.

Building your own Push Button for External dimming:

Note: Requires soldering and assembly. It is expected that the technician has experience in electronics, soldering and assembling cables and connectors.

Use 1 cable that contains at least 3 wires (not 3 single wires), or 2 cable that contains at least 2 wires. Heat Shrink Tubes must be applied to soldered wire/pins. Test connection (beep) with Voltage Meter.

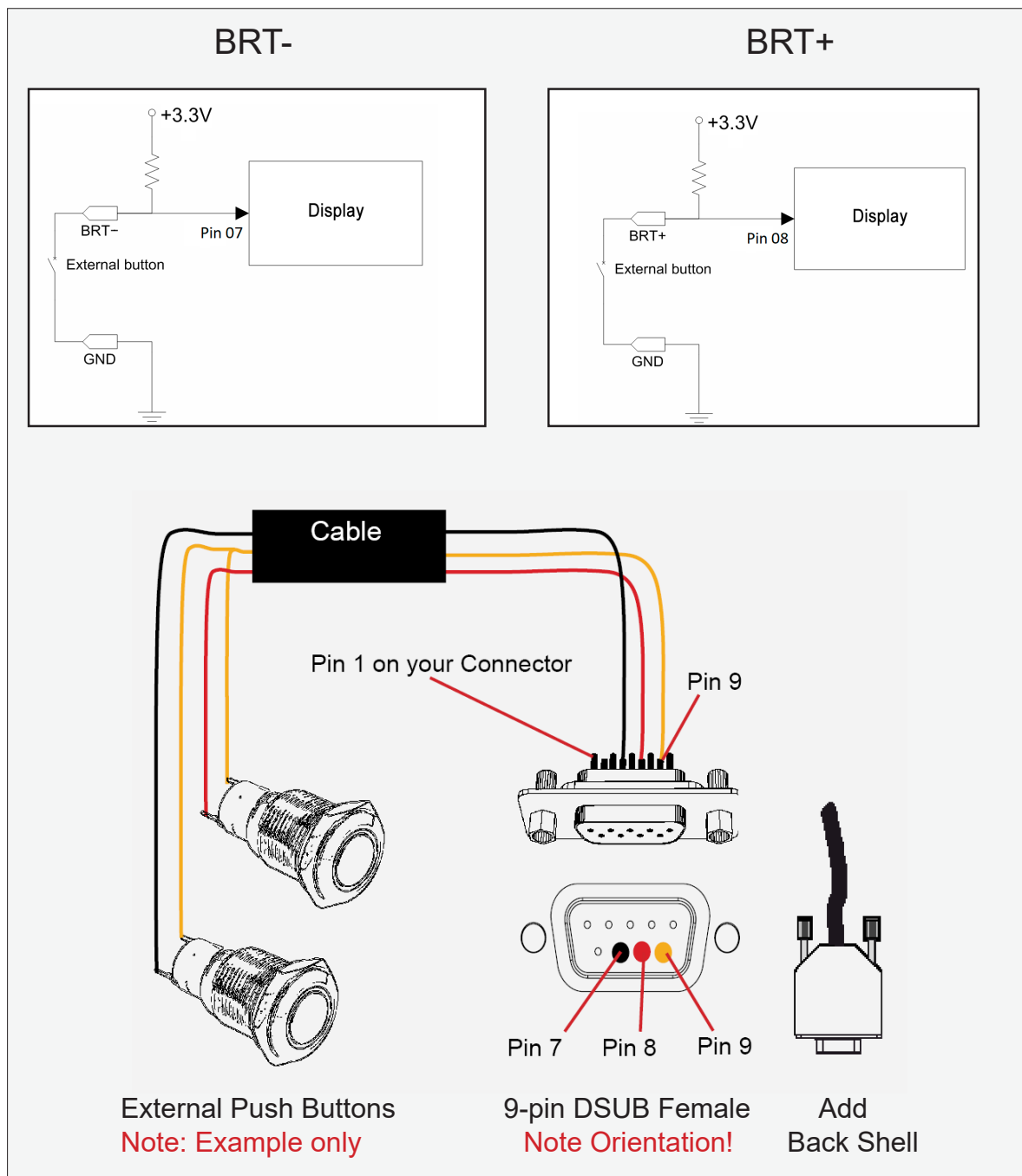

10-pin RS-422 / RS-485 Module w/Buzzer



All pinout assignments are seen from users Point of View (POV) while looking straight at the connector.

“RS-422/RS-485 SCOM + Buzzer” (Internal Buzzer can be controlled externally).

Pin 1,3,5,7 = RS-485 Full Duplex (4-wire)

Pin 5,7 = RS-485 Half Duplex (2-wire)

To ensure that EMC requirements are met, all connected cables shall be screened and should be terminated / grounded at both ends with as short as possible pig tail.

Buzzer - External Drive Logic:

- Able to supply 12VDC+/-5%@100mA
- Short circuit protected at <500mA
- <50VDC from ground of Display unit (Our input is isolated, this is layout limitation)
- Our input is classified as signal input, not power.

Notes:

Unit may have several physical connectors available for Buzzer control. Please only use RS-232 or RS-485 pins to control Buzzer, not both at the same time.

Series X (G1 - Generation 1):

- External drive logic can drive the buzzer even when the Display Unit is off.

Series X (G2 - Generation 2) / MVD Series:

- Display Unit needs external power connected to turn buzzer on. (Any logic power state).

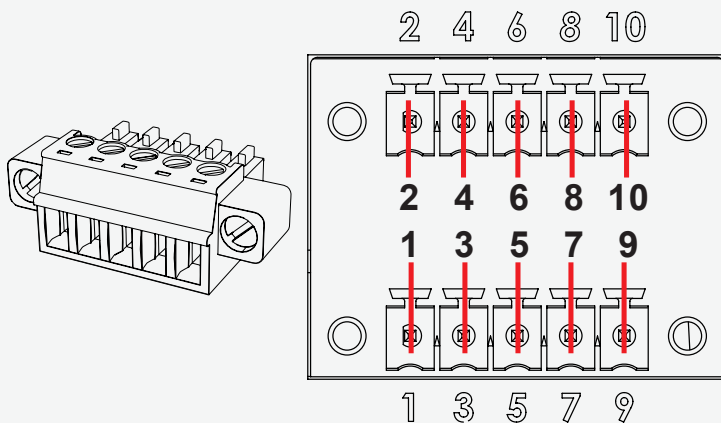

PIN 01	RxD+	Receive Data Positive
PIN 02	GND	Ground
PIN 03	RxD-	Receive Data Negative
PIN 04	+5V	+5V Out
PIN 05	TxD+	Transmit Data Positive
PIN 06	BUZ-	Buzzer Control Negative
PIN 07	TxD-	Transmit Data Negative
PIN 08	BUZ+	Buzzer Control Positive
PIN 09	GNDR	Ground 100Ω
PIN 10	GND	Ground

10-pin RS-422 / RS-485 Module w/Buzzer



Suggested "Buzzer" Control Logic inside Computer/System illustrated below. Display Unit needs external power connected to turn buzzer on. (Any logic power state).

For Military/Naval use: +12V line from customer system should be low pass filter or else the power ripple may cause radiated emission to fail. Use a cable that contains at least 2 wires (not 2 single wires). Test connection (beep) with Voltage Meter. Wires may be combined if using RS-422/485 COM as well.

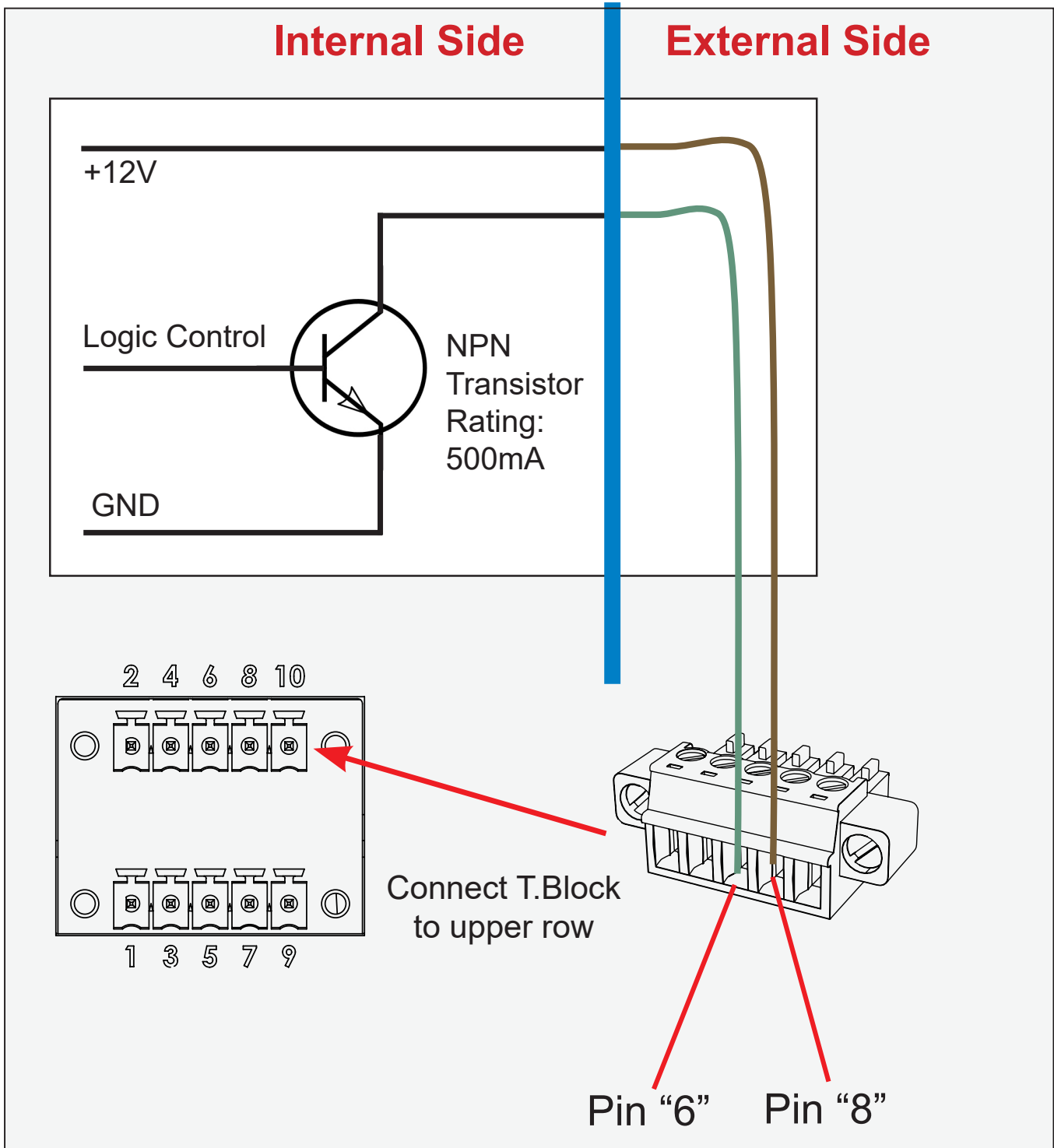

8-pin RJ45 10/100/1000Mbps LAN/Ethernet



All pinout assignments are seen from users Point of View (POV) while looking straight at the connector.

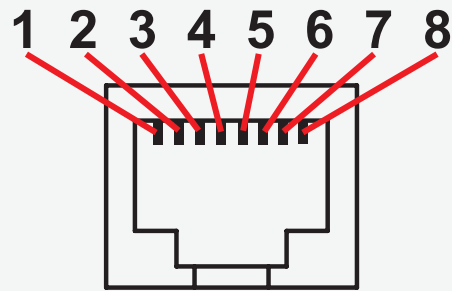

PIN 01	D0P+	Differential Pair 0 (Positive)
PIN 02	D0N-	Differential Pair 0 (Negative)
PIN 03	D1P+	Differential Pair 1 (Positive)
PIN 04	D2P+	Differential Pair 2 (Positive)
PIN 05	D2N-	Differential Pair 2 (Negative)
PIN 06	D1N-	Differential Pair 1 (Negative)
PIN 07	D3P+	Differential Pair 3 (Positive)
PIN 08	D3N-	Differential Pair 3 (Negative)

4-pin USB2.0 TYPE A Female



All pinout assignments are seen from users Point of View (POV) while looking straight at the connector.

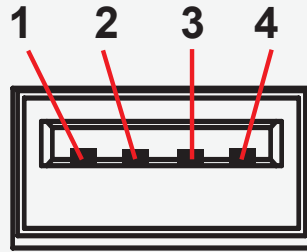

PIN 01	VCC +5V	Power
PIN 02	D-	Negative Data
PIN 03	D+	Positive Data
PIN 04	GND	Ground

24-pin USB-C TYPE A Female



All pinout assignments are seen from users Point of View (POV) while looking straight at the connector.

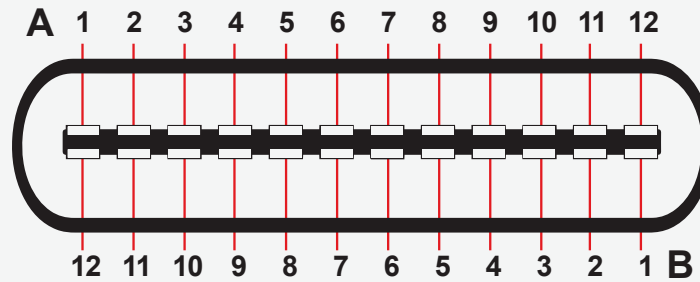

Pin A1	GND	Ground return
Pin A2	SSTXp1	SuperSpeed differential pair #1, TX, positive
Pin A3	SSTXn1	SuperSpeed differential pair #1, TX, negative
Pin A4	VBUS	Bus power
Pin A5	CC1	Configuration channel
Pin A6	Dp1	USB 2.0 differential pair, position 1, positive
Pin A7	Dn1	USB 2.0 differential pair, position 1, negative
Pin A8	SBU1	Sideband use (SBU)
Pin A9	VBUS	Bus power
Pin A10	SSRXn2	SuperSpeed differential pair #4, RX, negative
Pin A11	SSRXp2	SuperSpeed differential pair #4, RX, positive
Pin A12	GND	Ground return
Pin B12	GND	Ground return
Pin B11	SSRXp1	SuperSpeed differential pair #2, RX, positive
Pin B10	SSRXn1	SuperSpeed differential pair #2, RX, negative
Pin B9	VBUS	Bus power
Pin B8	SBU2	Sideband use (SBU)
Pin B7	Dn2	USB 2.0 differential pair, position 2, negative
Pin B6	Dp2	USB 2.0 differential pair, position 2, positive
Pin B5	CC2	Configuration channel
Pin B4	VBUS	Bus power
Pin B3	SSTXn2	SuperSpeed differential pair #3, TX, negative
Pin B2	SSTXp2	SuperSpeed differential pair #3, TX, positive
Pin B1	GND	Ground return

Revision history pr. chapter/document id

IND100106-7 - User Documentation statement - Rev: 01 - Date: 14 Aug 2025 - Author: SR

Initial version

IND100131-67 - Contents of package - Rev: 01 - Date: 17 Jan 2025 - Author: SR

Initial version

IND100078-81 - Safety introduction and overview - Rev: 01 - Date: 20 Jan 2023 - Author: SE

Initial version

IND100110-12 - Touchscreen overview - Rev: 01 - Date: 16 Oct 2024 - Author: SE

Initial version

IND100110-22 - Touch Screen drivers and calibration - Rev: 01 - Date: 14 Aug 2025 - Author: SR

Initial version

IND100077-321 - Product labeling and locations - Rev: 01 - Date: 10 Sep 2024 - Author: SR

Initial version

IND100077-322 - Product labeling details - Rev: 01 - Date: 10 Sep 2024 - Author: SR

Initial version

IND100210-14 - Housing / terminal block connector overview - Rev: 01 - Date: 20 Jan 2023 - Author: SE

Initial version

IND100078-123 - Installation recommendations - Rev: 01 - Date: 20 Jan 2023 - Author: SS

Initial version

IND100078-45 - Panel Cutout / Console Mounting Bracket Kit for 15, 17 and 19 inch - Rev: 01 - Date: 20 Jan 2023 - Author: SE

Initial version

IND100078-46 - Panel Cutout / Console Mounting Bracket Kit for 24 and 27 inch - Rev: 01 - Date: 20 Jan 2023 - Author: SE

Initial version

IND100078-115 - Mounting Bracket, Table / Desktop / Ceiling - 15, 17 and 19 inch - Rev: 01 - Date: 12 Sep 2024 - Author: SR

Initial version

IND100078-116 - Mounting Bracket, Table / Desktop / Ceiling - 24 and 27 inch - Rev: 01 - Date: 24 Oct 2024 - Author: SR

Initial version

IND100133-101 - Physical Connections MMD SeriesX-G3 - Rev: 01 - Date: 19 Aug 2025 - Author: SR

Initial version

IND100133-106 - Physical connections (Expansion Board) - Rev: 01 - Date: 19 Aug 2025 - Author: SS

Initial version

IND100064-40 - User controls - Rev: 01 - Date: 20 Jan 2023 - Author: SE

Initial version

IND100064-90 - On Screen Display (OSD) Menu - Functions map - Rev: 01 - Date: 19 May 2025 - Author: SR

Initial version

IND100064-91 - On Screen Display (OSD) Menu - Functions - Rev: 01 - Date: 19 May 2025 - Author: SR

Initial version

IND100084-17 - Serial Communication (SCOM) Interface - Introduction - Rev: 01 - Date: 31 Oct 2024 - Author: SR

Initial version

IND100084-48 - Message commands and queries - Rev: 01 - Date: 14 Aug 2025 - Author: SS

Initial version

IND100084-51 - MCC Commands List - Rev: 01 - Date: 14 Aug 2025 - Author: SS

Initial version

IND100084-23 - Operational requirements - Rev: 01 - Date: 20 Jan 2023 - Author: SE

Initial version

IND100077-259 - Calculating checksums (IDCHK, IHCHK) - Rev: 01 - Date: 20 Jan 2023 - Author: SE

Initial version

IND100077-122 - HEX, ASCII, BIN and character tables - Rev: 01 - Date: 20 Jan 2023 - Author: SE

Initial version

IND100077-124 - C# / pseudo ethernet/TCP code example - Rev: 01 - Date: 20 Jan 2023 - Author: SE
Initial version

IND100064-52 - Operation Advanced (DDC/CI) Control Overview - Rev: 01 - Date: 20 Jan 2023 - Author: SE
Initial version

IND105446-3 - 2-pin Terminal Block 5.08 - DC Power Input - Rev: 01 - Date: 17 Feb 2023 - Author: SE
Moved from Datasheet to this document

IND105446-79 - Grounding Screw - Rev: 01 - Date: 20 Feb 2023 - Author: SE
Initial version

IND105446-36 - 9-pin Serial COM RS-232+Buzzer non-isolated, DSUB Male - Rev: 01 - Date: 22 Feb 2023 - Author: SE
Initial version

IND105446-4 - 20-pin DisplayPort (DP) Female - Rev: 01 - Date: 17 Feb 2023 - Author: SE
Initial version

IND105446-16 - PinoutAssignments 19pin HDMI2.0 Female - Rev: 01 - Date: 27 Jun 2024 - Author: SR
Initial version

IND105446-32 - 9-pin User User Interface/ON-OFF/Dimming, DSUB Male - Rev: 01 - Date: 31 Mar 2023 - Author: SR
Initial version

IND105446-11 - 10-pin RS-422 / RS-485 Module w/Buzzer - Rev: 01 - Date: 31 Mar 2023 - Author: SE
Initial version

IND105446-1 - 8-pin RJ45 10/100/1000Mbps LAN/Ethernet - Rev: 01 - Date: 17 Feb 2023 - Author: SE
Moved from Datasheet to this document

IND105446-73 - 4-pin USB2.0 TYPE A Female - Rev: 01 - Date: 20 Feb 2023 - Author: SE
Initial version

IND105446-76 - 24-pin USB-C TYPE A Female - Rev: 01 - Date: 15 Aug 2023 - Author: SE
Initial version

IND100078-80 - IEC62368 policy - Rev: 01 - Date: 20 Jan 2023 - Author: SE
Initial version

IND100077-185 - Troubleshooting - Rev: 01 - Date: 20 Jan 2023 - Author: SE
Initial version

IND105367-1 - Parts and recycling - Rev: 01 - Date: 21 Jan 2023 - Author: SR
Initial version

IND100077-171 - General notes - Rev: 01 - Date: 20 Jan 2023 - Author: SE
Initial version

Legacy revision history

Rev: 04 - Date: 12 Dec 2002

Description: Last version to be published, no revision history recorded before this.