

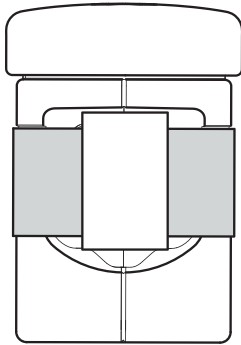

 **mod**
user manual

Copyright 2020 Catchbox SIA





Catchbox Mod

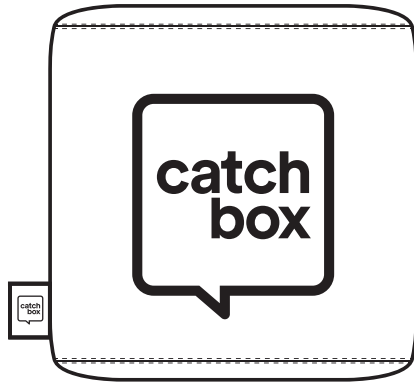

Catchbox Cover

Contents

1 Safety Instructions	4-5
2 Quick Start	6-15
3 Product Description	16-18
Overview.....	16
Compatibility.....	17
Included cables.....	18
Proper Use and Working Environment	19
4 System Overview	20
Catchbox Mod.....	21
Catchbox Cover.....	22
Catchbox Mod (Without 3rd Party Transmitter).....	23
5 Operations	24
Turning the Device On.....	24
Locking the Transmitter to the Cover	25
Opening the Catchbox.....	26
Throwing the Catchbox.....	27
Speaking into the Catchbox	28
6 Troubleshooting	29
7 Maintenance, Storage, and Disposal	30

2 Safety Instructions

! NOTICE !



- Before using the product, read and understand the user manual and inform others of proper usage.
- Follow all warnings and instructions on the product and in this manual.
- Keep these instructions and always include these instructions when passing the apparatus on to third parties.

! WARNING !



- Not heeding these warnings might lead to serious injury or property damage.
- Do not throw at peoples' heads and always make sure everyone is aware of the situation before throwing.
- Do not use in situations with fragile objects, hot liquids, or people susceptible to injury, like the very young or old.
- Do not throw long passes or hard passes.
- Properly lock the Mod into the cover before use. Always use the cover and the foam cap on the Mod, when using the product.
- Only use compatible 3rd party transmitters, as specified by the manufacturer, with the Mod. Using incompatible transmitters may result in damage to audio equipment, an increase in overall product weight leading to an increased chance of injury, and/or a failure of the locking mechanism causing the Mod or 3rd party transmitter to fall out during use causing injury.
- Operating or storing this product at temperatures above 50 degrees Celsius or 122 degrees Fahrenheit will cause the locking mechanism to fail permanently.
- This product contains magnets which could affect the functioning of pacemakers and other electronic implants. These could stop working or switch into test mode, causing illness. If you wear these devices keep sufficient distance to magnets. Warn others who wear these devices from getting too close to magnets.

! CAUTION !



- Magnets produce a far-reaching, strong magnetic field. Keep magnets away from devices and objects that could be damaged by strong magnetic fields, like laptops and other electrical equipment.
- Do not place the product near heat sources such as heating ducts or radiators and do not expose it to direct sunlight, excessive dust, moisture, rain, mechanical vibrations or shock.
- Do not use near water. Use equipment indoors only. If the equipment comes into contact with a liquid, turn off the product and shut down the sound system.
- Avoid excessive volume. Do not exceed 70dBa for airborne noise.
- Clean the equipment with a moistened (not wet) cloth only. Be sure to turn off the device before cleaning the equipment, during lightning storms, and/or when not in use.
- The equipment should be opened, serviced, and repaired by qualified service personnel only.
- Do not attempt to modify this product or its accessories and use only accessories and attachments, specified by the manufacturer.
- Use only AA (LR6) type alkaline batteries with the product.
- Be sure to dispose of dead batteries as required by local waste disposal rules. Never throw batteries into a fire or a garbage bin

3 Quick Start

Catchbox Mod uses 3rd party wireless transmitters to function. For a list of compatible transmitters, see the section on compatibility or visit the manufacturers website, www.catchbox.com.

1.

Setup a compatible 3rd party transmitter and receiver pair, syncing the two units and connecting the receiver to a sound system. For specific instructions, see the relevant user manual provided by the manufacturer of said system.

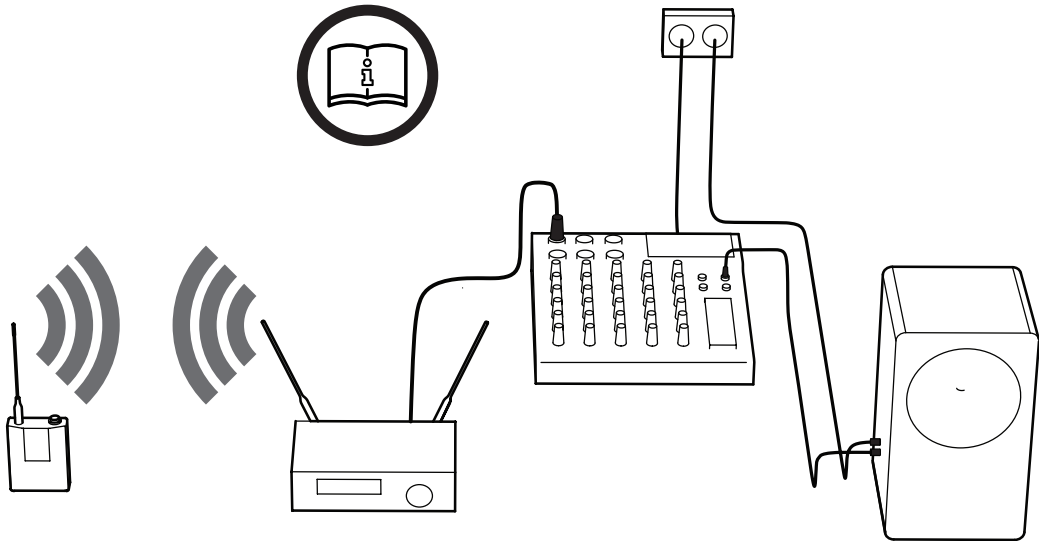



AKG®



SHURE®



SENNHEISER®

2.

Choose an adapter cable based on the brand and model of your 3rd party transmitter and connect it to the microphone input of said transmitter.

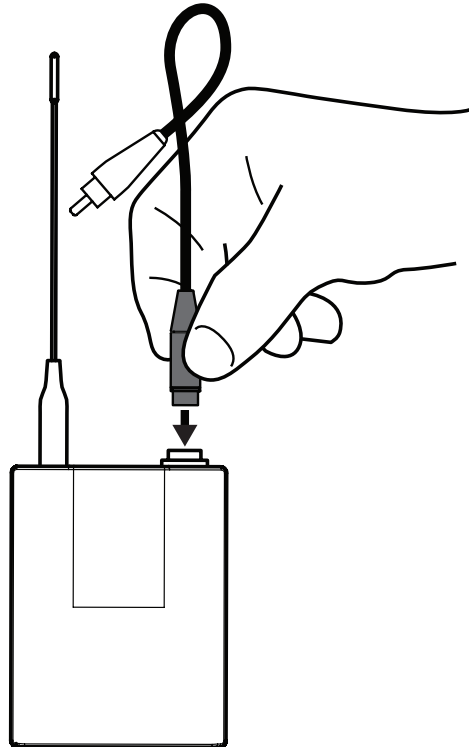

3.

Remove the Catchbox Mod from the outer cover by twisting the cylinder 90 degrees and pulling upwards.

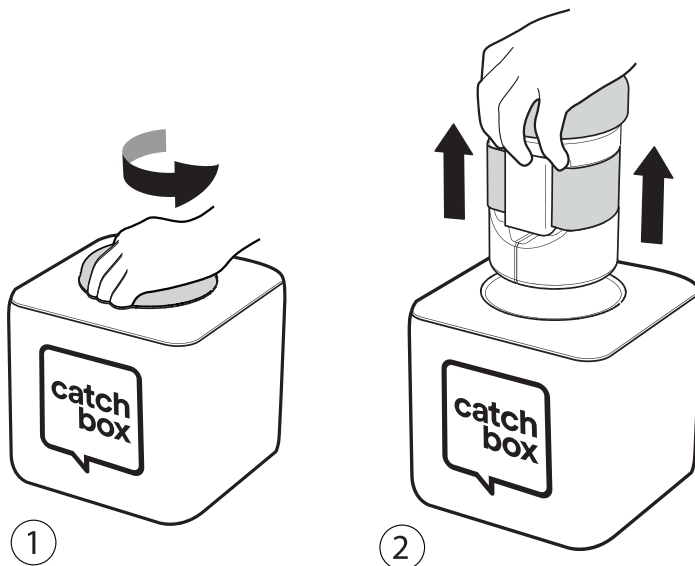

4.

Open the velcro strap surrounding the device by pulling it gently along the surface of the Mod.

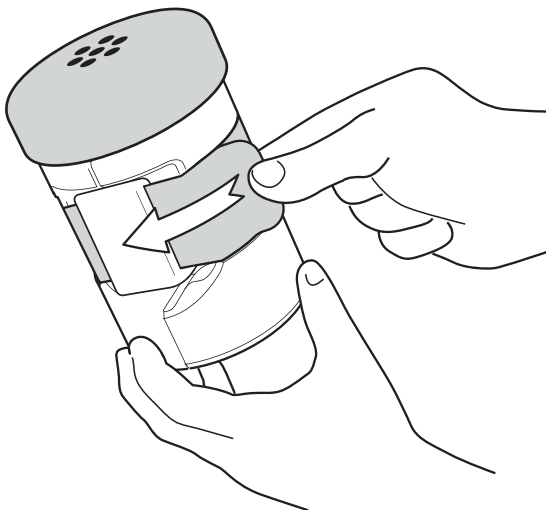

5.

Install one AA battery into the back part of the Catchbox Mod.

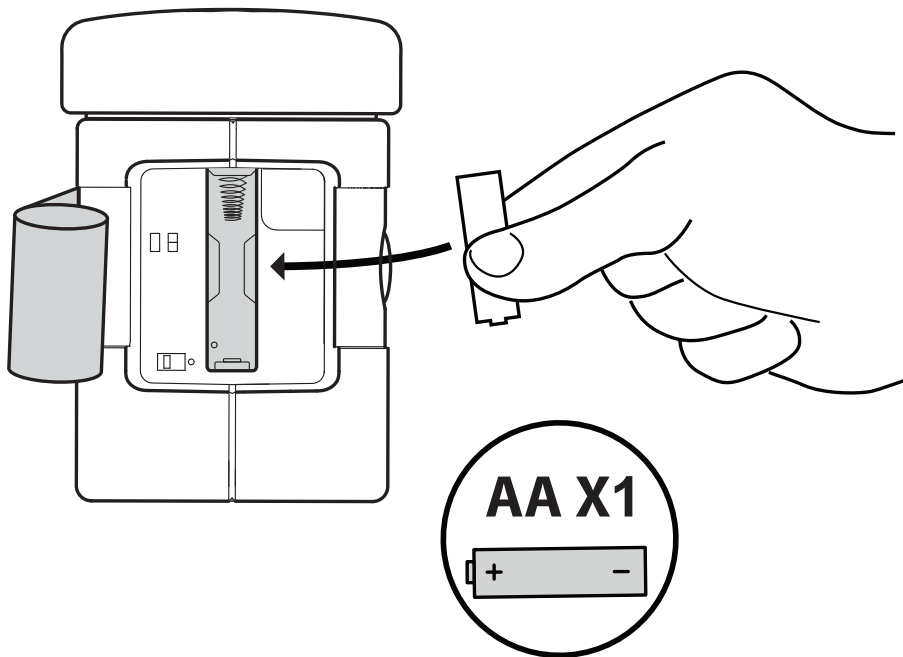

6.

Connect the 3rd party transmitter to the Catchbox Mod by plugging the RCA male end of the adapter cable into the RCA female connector, located inside the front cavity of the Catchbox Mod.

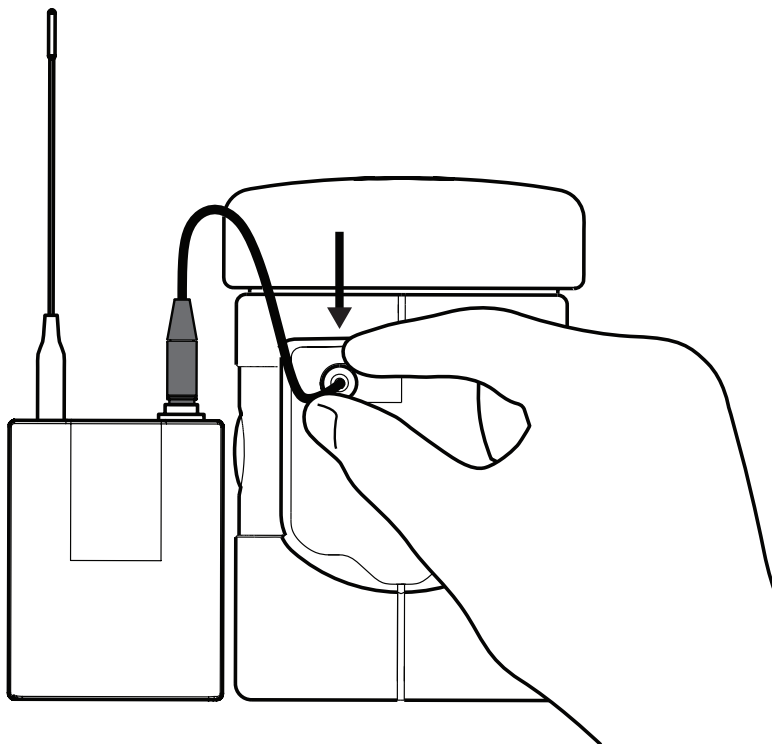

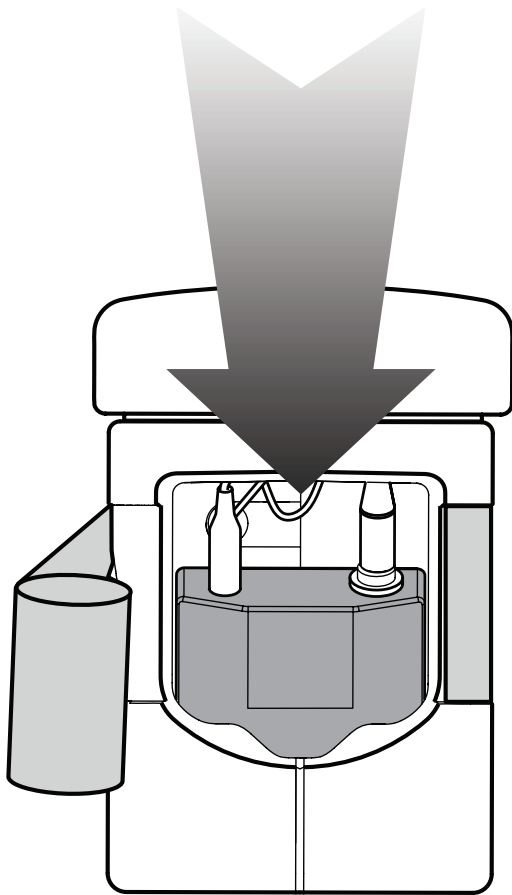

7.

Place the transmitter inside the cavity of the Catchbox Mod making sure no antennas or cables are protruding outwards.

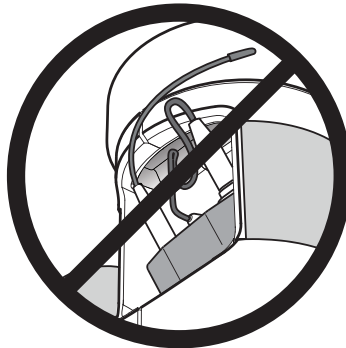
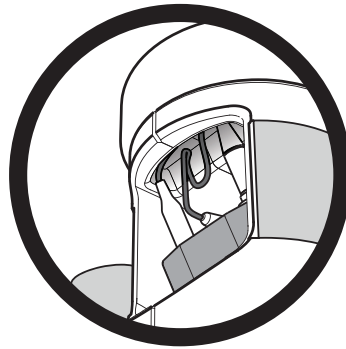

8.

Turn on both the 3rd party transmitter and the muting circuit located at the back of the Catchbox Mod.

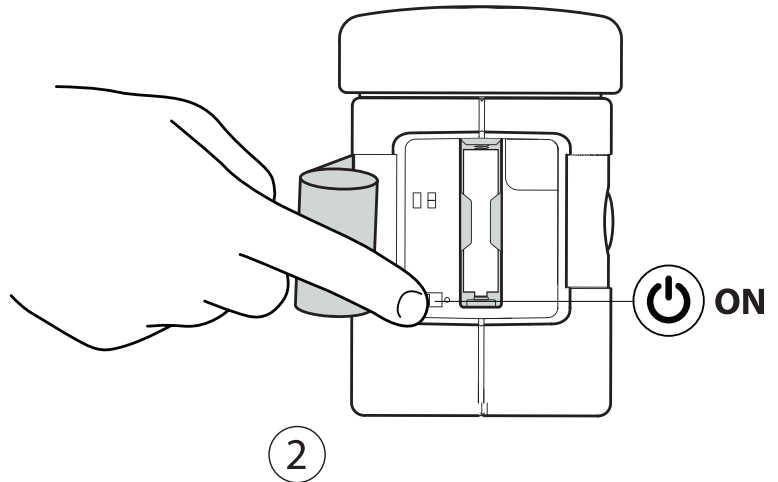
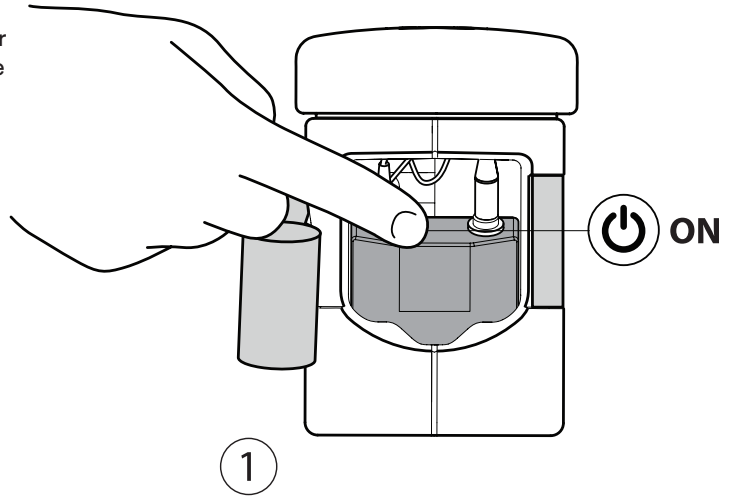

9.

Secure the velcro strap tightly around the Catchbox Mod, ensuring that both the battery located at the back as well as the frontal cavity are covered by the velcro strap.

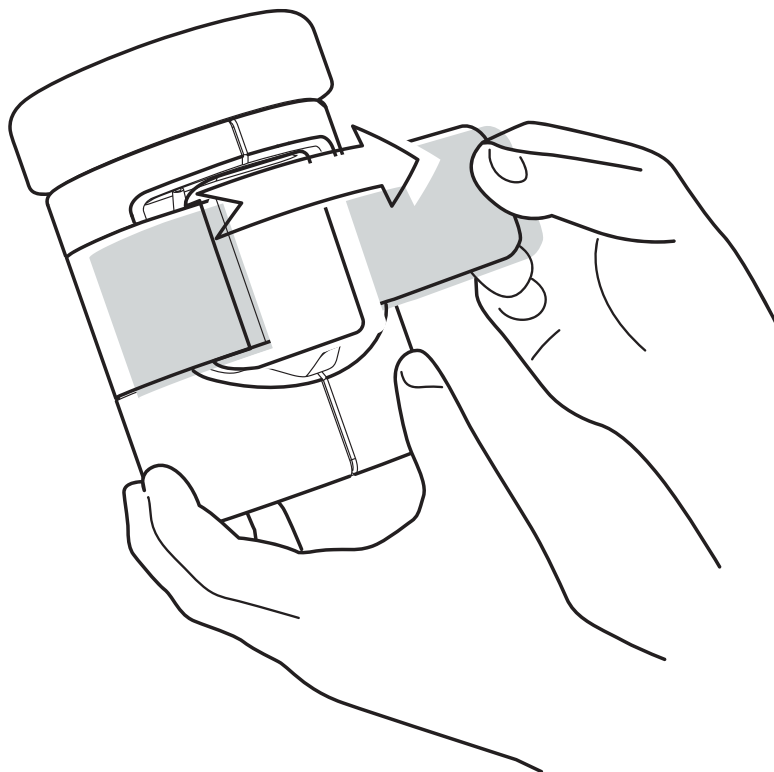

10.

Place the Catchbox Mod inside the cover, making sure to align the magnetic locking mechanisms of both the cover and the Catchbox Mod. See visual marks for guidance.

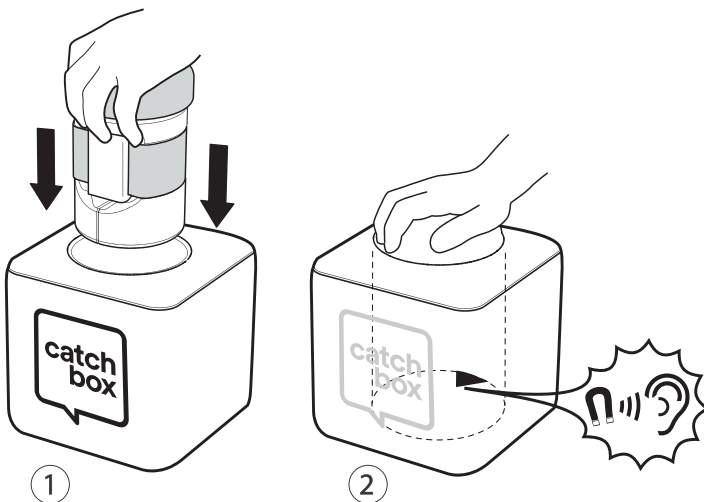
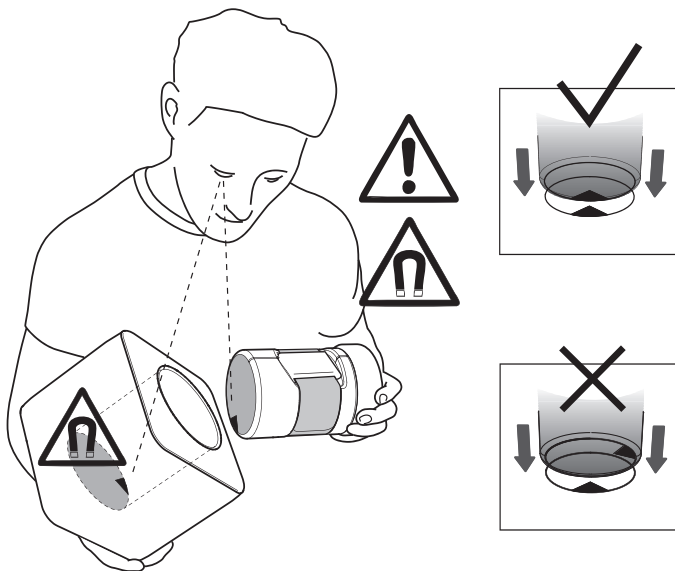

11.

Test the volume level by speaking into the microphone and adjusting it using the volume controls on the 3rd party transmitter or receiver.

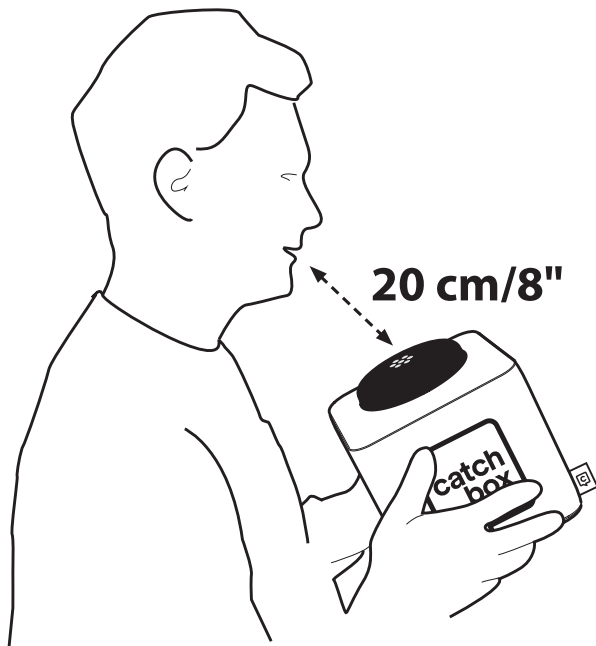

! CAUTION !

Avoid excessive volume. Do not exceed 70 dBa for airborne noise. Before turning on the device, make sure the volume knob on your 3rd party receiver is turned to zero, so as to ensure no unexpected loud noises when starting.

4 Product Description

Overview

Catchbox Mod is the world's first throwable microphone Mod, allowing audio professionals to convert existing wireless microphone transmitters into soft, throwable microphones. These final assemblies, in turn, can be quickly passed from one audience member to the next in crowded spaces, making it an easy and fun way to get audience members to ask questions and make comments, whether it be in a lecture, a meeting, a workshop, or even a conference. The Mod comes with an integrated professional microphone element connected to the unique automute technology, which turns off the audio signal when the microphone is in movement, ensuring the system doesn't make any unwanted noises when being passed around. The Catchbox Mod itself does not act as a transmitter. Instead, wireless transmission is carried out entirely by the 3rd party wireless transmitter. This means no separate license is required to operate the Mod as long as one has been obtained for the 3rd party wireless transmitter.

Key Features

- Automute technology
- Integrated Microphone Element
- Compatible with industry leading wireless microphone brands

Included Components

- Catchbox Mod
- Catchbox Cover
- RCA to 3 pin mini XLR adapter cable
- RCA to 4 pin mini XLR adapter cable
- RCA to 3.5 mm plug adapter cable



! CAUTION !

Do not attempt to modify this product or its accessories and use only accessories and attachments specified by the manufacturer.

Included cables

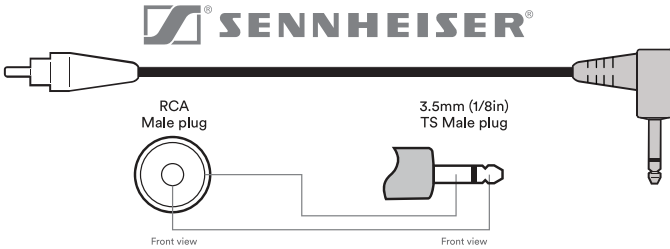
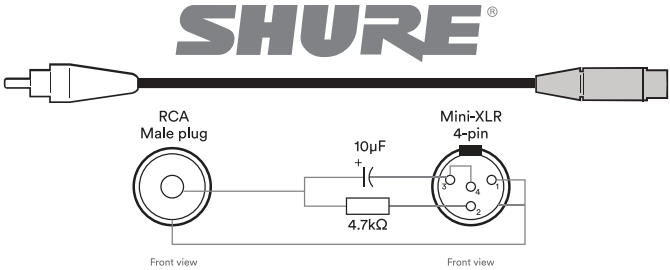
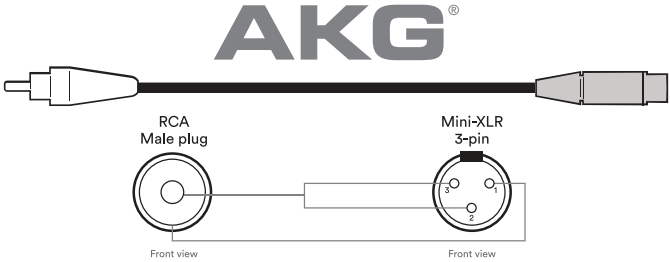

Compatibility

The Catchbox Mod, wireless microphone Mod, allows audio professionals to convert 3rd party wireless microphone transmitters into throwable microphones. The device comes with different adapter cables which allow users to connect commonly used 3rd party transmitters to the integrated microphone element and automatic muting circuit. Currently, the Catchbox Mod has been tested and verified to work with the following models of transmitters from Shure™, AKG™ and Sennheiser™ :

Compatible Belt-pack Transmitters:

Shure	Sennheiser		AKG	
ULXD1	SK 100 G3	SK 500 G4	PT470	DPT800
QLXD1	SK 100 G3 1G8	SK 300 G4	PT420	DPT700
UR1M	SK 500 G3	SK 100 G4	PT45	PT40 Pro
GLXD1	SK 100 G2	XSW-D	PT40 mini	PT40 Flexx
AD1 with TA4 connector	SK 100 G4			

These transmitters have been tested to fit into the cavity inside the Catchbox Mod. It is important not to use 3rd party transmitters, other than those mentioned above, as these can be too heavy or oversized, making the device unsafe to throw.

To connect a compatible 3rd party transmitter to the Catchbox Mod, the device comes with three different adapter cables. These cables have different pin layouts depending on the brand of the transmitter you would like to use. Simply choose the adapter cable that matches the pin layout of your compatible belt-pack transmitter.

Proper Use and Working Environment

Safety First

While the Catchbox Mod is a fun way to make events more engaging, improper use can lead to personal injury and/or property damage. Please understand that the manufacturer accepts no liability for damage or injuries arising from the misuse of this product. It is very important to read the safety instructions before using the product. Specifically, make sure that the Catchbox Mod, along with the 3rd party wireless transmitter, is securely locked inside the foam cover before using the product. Remember to only use 3rd party wireless transmitters specified as being compatible with the product by the manufacturer. Also, do not throw long or hard passes, and avoid using the device in situations where there are glasses, fragile items, hot liquids, unsuspecting people, or people susceptible to injury, like the very old or young. Also, avoid swinging or throwing the device from its handle as this may cause the locking mechanism to fail, releasing the inner part and potentially causing injury.

Things to Consider With Magnets

Since the product contains magnets, care should be taken when setting up the product for use. Avoid placing the Mod on electrical devices, such as laptops, as these can be adversely affected or damaged from the magnetic field. People with pacemakers or other electrical implants should be especially careful, as these devices could stop working or switch into test mode if they come into direct contact with a strong magnet.

5 System Overview

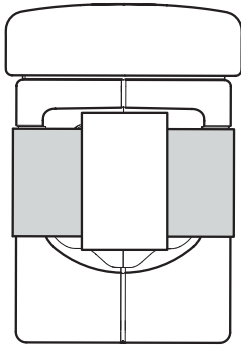

Catchbox
Mod

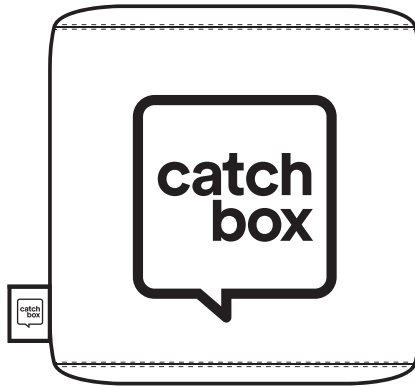

Catchbox
Cover

NOTE: Catchbox Mod uses compatible 3rd party wireless transmitters to work. Some specifications of the system are reliant on the make and model of the 3rd party wireless transmitter that is used with the product. These specifications include range of operation, radio frequency, audio frequency response, and system latency.

Catchbox Mod

Parts

- 1) Foam Cap
- 2) RCA Port
- 3) Velcro Straps
- 4) Microphone Element
- 5) Cavity for 3rd Party Transmitter
- 6) Magnetic Lock
- 7) Battery Compartment
- 8) Status LED
- 9) Power Switch

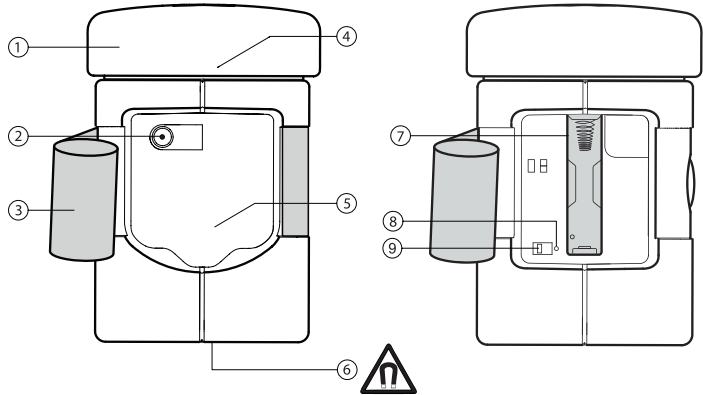

General Specifications

Weight (with Cover, without wireless transmitter)	280 g / 9.90 oz	Microphone element	Electret condenser, omni-directional
Dimensions (with Cover)	180 x 180 x 180 mm / 7 x 7 x 7 in	Additional audio latency	0 ms
Built-in Automute technology	Yes	Audio frequency response	30 to 20000 Hz
Working range	Depends on the wireless system used	Operating temperature range	W0 °C (32 °F) to 30 °C (86 °F)
Battery type	1 x AA (LR6)	Storage temperature range	0 °C (32 °F) to 50 °C (122 °F)
Battery life	>20 hours (with alkaline battery)	Wireless charger compatible	No

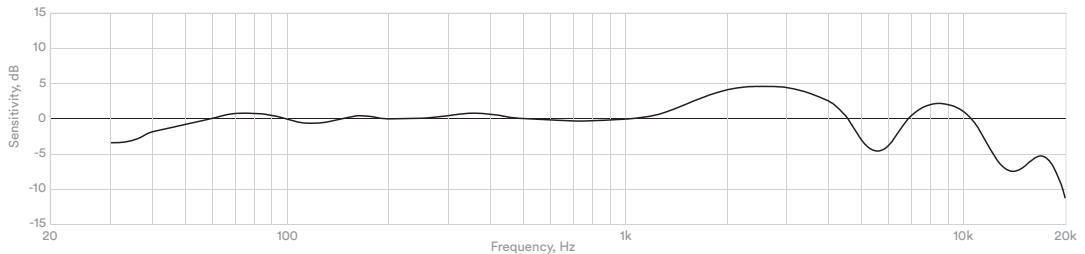

Catchbox Cover

Parts

- 1) Opening for Mod
- 2) Magnetic Lock

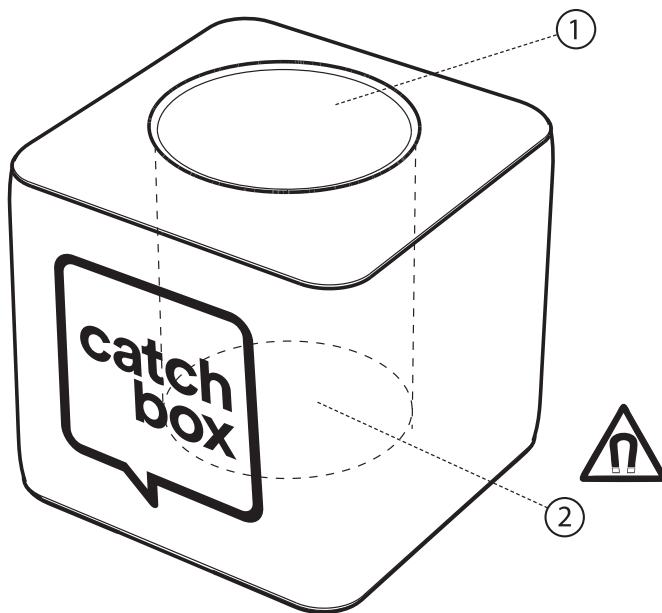

Specifications

Weight

200 g / 7 oz

Dimensions

18 x 18 x 18 cm / 7 x 7 x 7 in

Catchbox Mod (Without 3rd Party Transmitter)

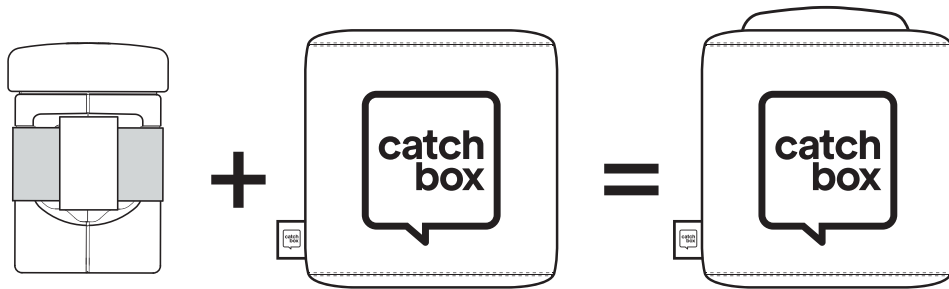

Specifications

Weight

280 g / 9.90 oz

Dimensions

18 x 18 x 18 cm / 7 x 7 x 7 in

6 Operations

Turning the Device On

To turn on the device, place one AA battery in the muting circuit of the Catchbox Mod and an appropriate battery into the 3rd party transmitter. Then turn on both the muting circuit and 3rd party transmitter. The LED on the back side of the Catchbox Mod should turn green. Secure the AA battery and the 3rd party transmitter in place by tightening the velcro strap around the device as shown in the picture.

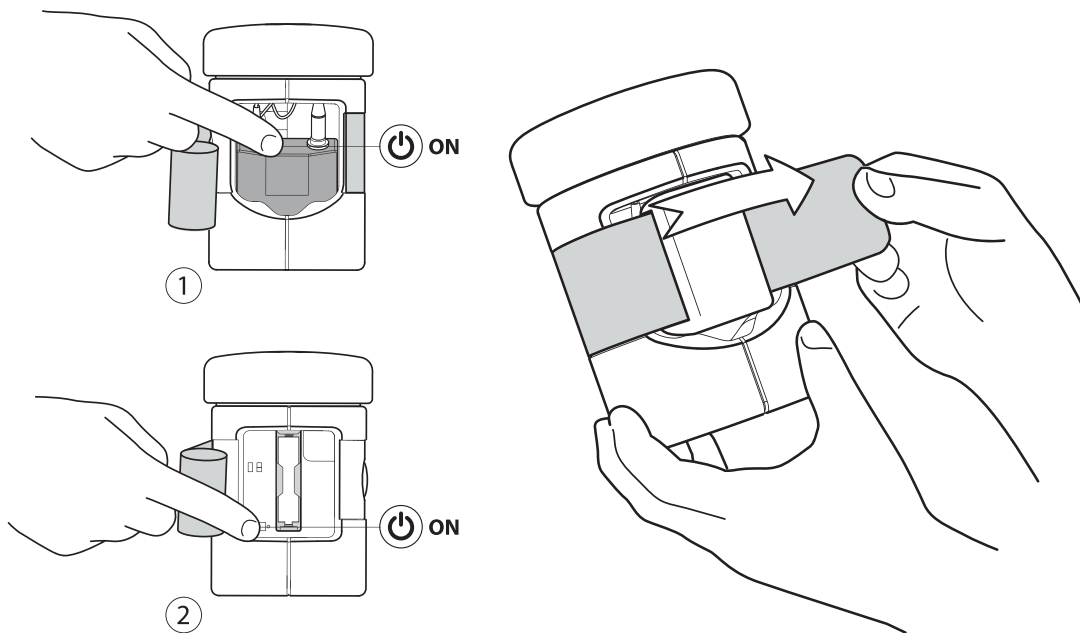

Locking the Mod Into the Cover

To lock the Catchbox Mod unit into the cover, align the pictures located at the bottom of the Catchbox Mod and bottom of the cover with each other. The locking mechanism is composed of two magnets that attract each other when correctly aligned. To test whether the locking has been successful, one can try to pull on the Catchbox Mod and attempt to remove it with a vertical force. If it does not come out with significant force, the magnets are correctly aligned. To remove the Catchbox Mod, simply twist it 90 degrees and pull. This motion will misalign the magnets and allow for easy removal of the inner part.

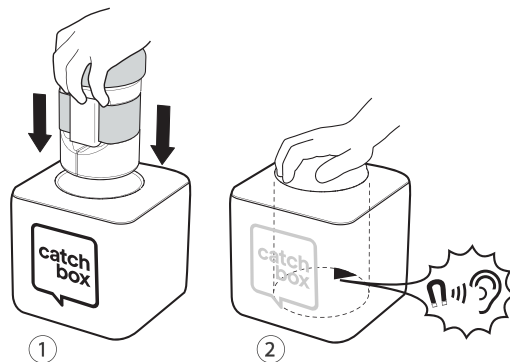
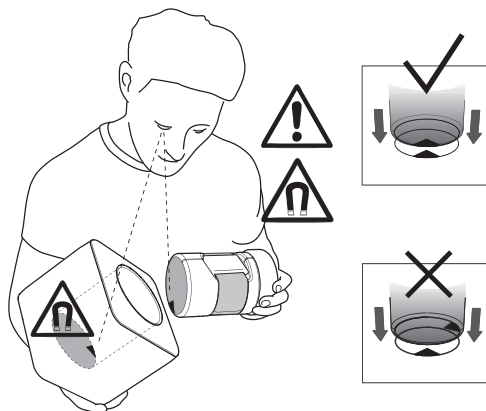

! WARNING !

Always properly lock the Catchbox Mod, with the attached foam cap, into the cover before use. Improperly locking the Catchbox Mod, or a failed locking mechanism, will result in the unit coming out during use, potentially leading to serious injury and/or property damage.

Opening the Catchbox

To remove the Catchbox Mod, simply twist it 90 degrees and pull upward. This motion will misalign the magnets and allow for easy removal of the unit.

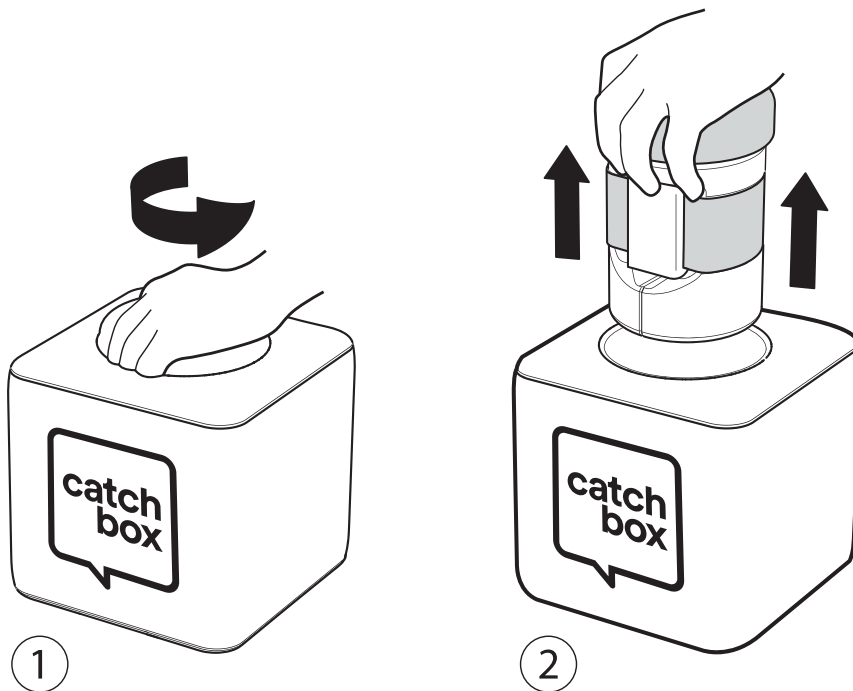

Throwing the Catchbox

To throw the Catchbox microphone, find someone in the audience who wants to ask a question or make a comment. Make sure that the person and those around him or her are aware of the situation and are prepared to catch the microphone. Avoid throwing the Catchbox if there are fragile electronics or hot liquids nearby, as these might spill or be damaged from the throw. Short, underhand passes of around 5 meters / 16ft. distance are recommended. If someone farther away has a question, try to get the entire audience involved by having members pass the Catchbox short distances to the person who wants it. This is a great way to activate the crowd.

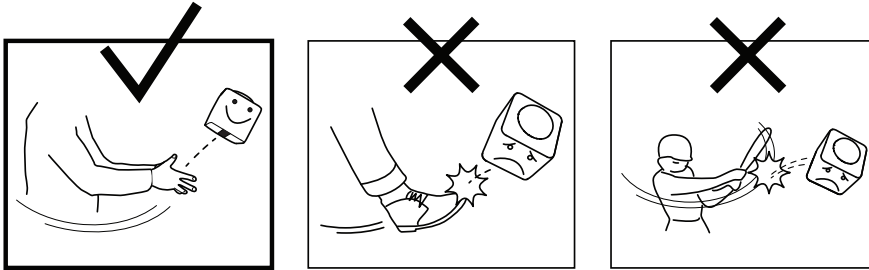

! WARNING !

Improper throwing and use of the device can lead to serious injury and/or property damage. Do not throw at peoples' heads and always make sure everyone is aware of the situation before throwing. Do not use in situations with fragile objects, hot liquids, or people susceptible to injury, like the very young or old. Do not throw long passes or hard passes.

Speaking Into the Catchbox

To use the Catchbox, simply speak into the foam cap located on top of the product. It is advisable to inform audience members at what distance to speak into the Catchbox. A distance of 20cm / 8in is ideal. This will provide the clearest sound while not blocking the persons face who is speaking. Avoid using the Catchbox near speakers as this can cause audio feedback.

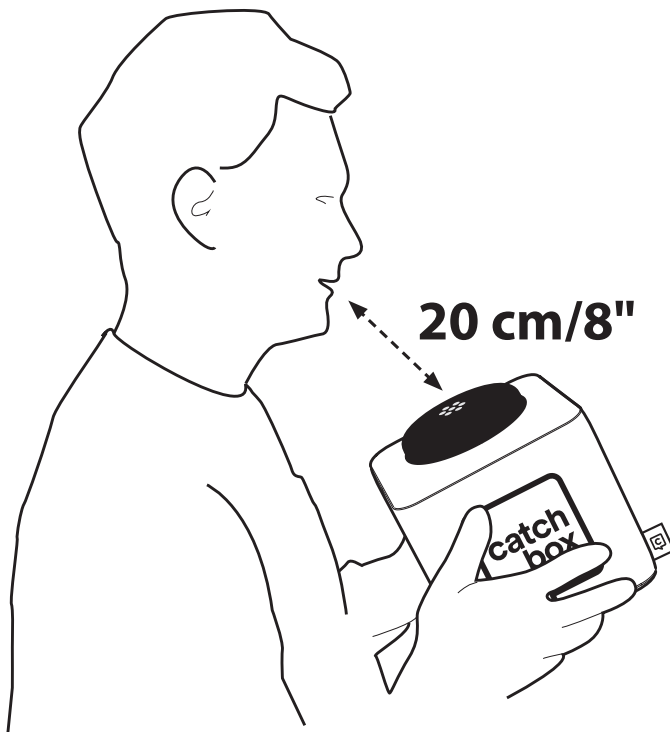

7 Troubleshooting

Problem	Possible Cause	Solution
No sound	1) Catchbox Mod is not turned on, indicated by no light on the status LED. 2) 3rd party transmitter or receiver is not turned on or these are not paired.	1) Turn on the Catchbox Mod using the power switch located at the back of the device. The LED status light should turn green. If it doesn't, you may need to replace the battery. 2) Make sure both the 3rd party wireless transmitter and receiver are on and paired with each other. See corresponding 3rd party user manual for further assistance..
Audio signal dropouts or breaks	1) Wireless connection between 3rd party transmitter and receiver is weak and unreliable.	1) See 3rd party transmitter and receiver user manual for more assistance. Common causes for a weak unreliable signal are that the receiver and the transmitter are located too far away from each other, the signal is being absorbed by objects between the two devices, and/or other devices are operating on the same frequency band, congesting the frequency band.
Distorted sound	1) Adapter cable is broken or not properly attached. 2) Volume too high.	1) Check the adapter cable connection to the 3rd party transmitter as well as to the Mod. If problem persists, replace the adapter cable. 2) Reduce the output volume at the receiver by using the volume knob.
Mod falling out of cover	1) The magnetic locks are misaligned. 2) Magnetic lock has been damaged or magnets have lost strength.	1) Align the magnets by twisting the Catchbox Mod inside the cover. 2) Get the product serviced.
Audio feedback	1) Catchbox microphone is situated too close to the speaker system.	1) Move Catchbox microphone away from the speakers.

For more technical assistance, contact us by email (info@catchbox.com) or visit our website (www.catchbox.com).

8 Maintenance, Storage, and Disposal

Proper maintenance and storage of the Catchbox Mod will help ensure the product remains operational and safe to use. Improper maintenance or storage, in turn, can lead to equipment failure which can cause serious injury during use. Do not attempt to repair the unit yourself. The equipment should be opened, serviced, and repaired by authorized personnel only. Always refer to the user manual for proper maintenance, storage, and disposal instructions and do not throw away the user manual. Always keep it near the product for reference by other users.

Cleaning

To clean the equipment, use a moistened (not wet) cloth only. Be sure to turn off the device before cleaning. To clean the outer cover, first remove the Catchbox Mod unit from the inside. Only use dry cleaners and do not place the outer cover in a washing machine. Always remember to inform cleaners that the device contains a magnet and should not be treated in temperatures in excess of 50 degrees Celsius, 122 degrees Fahrenheit, or near equipment sensitive to strong magnetic fields.

Storage

Magnets produce a far-reaching, strong magnetic field. Keep magnets away from devices and objects that could be damaged by strong magnetic fields, like laptops and other electrical equipment. Operating or storing this product above 50 degrees Celsius or 122 degrees Fahrenheit will cause the locking mechanism to fail permanently. This, in turn, will cause the Catchbox Mod to fall out of the cover during use, potentially leading to personal injury and/or property damage. Do not place the equipment near heat sources such as heating ducts or radiators and do not expose it to direct sunlight, excessive dust, moisture, rain, mechanical vibrations, or shock. Do not use or store near water. If the equipment comes into contact with a liquid, turn off the device along with the 3rd party transmitter attached to it.

Disposal

To dispose of a broken or defective unit, send the unit back to the manufacturer or consult your local waste management professional. Be sure to dispose of dead batteries as required by local waste disposal rules. Never throw batteries into a fire or a garbage bin.

9 Certification

The Catchbox Mod Consists of:

- Catchbox Mod (Model #: CBPRO001)



Catchbox Mod Transmitter

Product meets the essential requirements of the European R&TTE Directive 1999/5/EC and is found to comply with the following standards:

EN 301 489-1 v1.9.2

EN 55032:2012+AC:2013+AC:2014

EN 55024:2011

This device complies with Part 15 of the FCC Rules. Operation is subject to the following two conditions: (1) this device may not cause harmful interference, and (2) this device must accept any interference received, including interference that may cause undesired operation.



www.catchbox.com

