

# s24 sCharge 12W

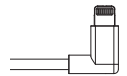

s24 L

**sCharge with Lightning cable**  
MPNo. sCh-12W-8pin-1.0  
EAN 4260258610246

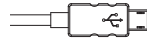

s24 m

**sCharge with micro USB cable**  
MPNo. sCh-12W-mUSB-1.0  
EAN 4260258612240

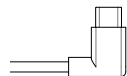

s24 C

**sCharge with USB-C cable**  
MPNo. sCh-12W-USB-C-1.0  
EAN 4260258612028

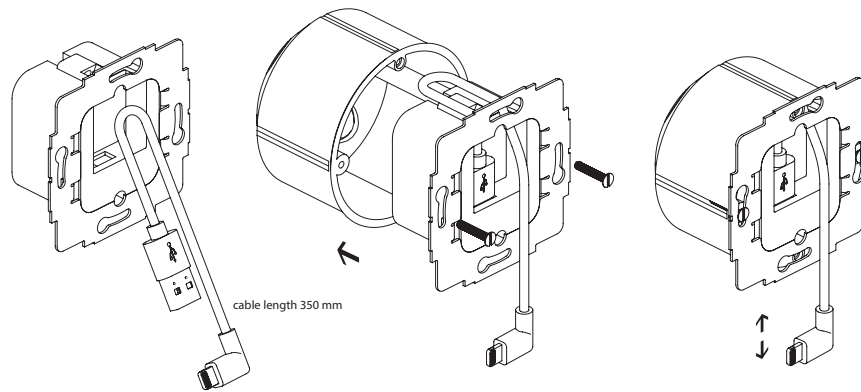

cable length 350 mm

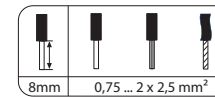
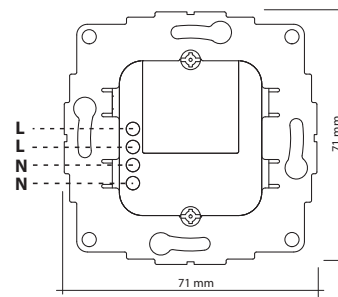
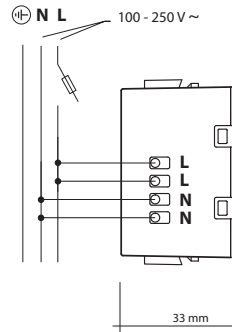

**sCharge 12 W**  
USB power supply



Type : JP - 3501 LP  
Input : 100 - 250 V ~ / 50 - 60 Hz  
Output : USB 4,75 - 5,25 V =, 2,4 A max.



WEEE DE 64398562

www.smart-things.com Made in China

## Instructions for use EN

**Function**  
This flush-mountable single-port USB charger charges the batteries of mobile devices. The USB charger is ideally suited for charging tablets which are installed on the wall, using commercially available wall mounts. The total output current of the charger is 2,4 A at 5V = (+/- 5%).  
The maximum permissible voltage is 250V ~ 50/60Hz 16A. Only install and use this IP20 protected product in protected locations with an ambient temperature between 5°C and 35°C. Avoid the influence of moisture, dust, sun or other heat radiation. For prolonged use, the housing of this product may become warm. This is normal.

**HAZARDWARNING!**  
• Operate this device only in indoor areas. Avoid the influence of moisture, dust, sun or other heat radiation.  
• This USB-Charger is part of the building installation. The relevant standards and directives of the country must be observed during planning and construction. The operation of the device is permissible only on the 230V / 50 Hz alternating current network. Work on the 230V mains may only be carried out by a certified electrician qualified in your country. The applicable accident prevention regulations must be observed.  
• To avoid an electric shock on the device, please disconnect the mains voltage to the device (switch off the circuit breaker). Failure to comply with the installation instructions may cause fire or other hazards.  
• The installation may only be carried out in commercially available flush-mounted wall boxes (installation boxes), with a minimum depth of 40mm.  
• When connecting the device terminals, observe the type of cabling which are permissible for this purpose.  
• Pay close attention to the wiring diagram!

**Mandatory information in accordance with the equipment safety standard:**  
Noted Only to be installed by persons with relevant electrical qualifications and experience!\*)

Improper installation will result in risk to your own life and risk to the life of persons using the electrical installation. With an improper installation, you risk serious material damages, for example fire. You are personally liable for personal injury and material damages. Please contact a qualified electrical engineer.

**\*) Specialist skills required for installation**  
In particular, the following special knowledge is required for the installation:  
• The applicable "Safety Rules": disconnect; protect against switching on; verify mains power disconnect; earthing and short-circuiting; covering adjacent current-carrying components or making them inaccessible.  
• Selection of suitable tools, measuring equipment and - if necessary - personal protection equipment.  
• Evaluation of measurement results.  
• Selection of the electrical installation material to ensure compliance with the shut-down conditions.  
• IP-Protection classes.  
• Installation of electrical installation material:  
• the resulting connection conditions (conventional protective multiple earthing, safety earthing, additional measures required etc.).

**Maintenance and cleaning**  
This USB-Charger is maintenance-free. Any repairs should only be carried out by a qualified electrician. Clean the unit with soft, clean, dry, lint-free cloth only. Please do not use solvent based cleaning agents. The plastic housing could be affected by this. Do not use wet cloths or sponges to clean the socket outlet.

**RoHS/WEEE Compliance Statement (Recycling Instructions)**  
European Directive 2012/19/EU requires that equipment bearing the trashcan symbol on the product and/or its packaging must not be disposed of with unsorted municipal waste. The symbol indicates that this product should be disposed of separately from regular household waste streams. It is your responsibility to dispose of this via designated collection facilities supported by the government or local authorities. Correct disposal and recycling will help prevent potential negative consequences to the environment and human health. For more detailed information about the disposal of your old equipment, please contact your local authorities, waste disposal service, or the shop where you purchased the product.

**Technical Specifications USB Charger**  
Input voltage 100 - 250V ~ 50/60 Hz  
Input current Max. 1,5 A  
Output voltage 4,75 - 5,25 V=  
Output current 0,01 - 2,4 A  
Output power 1,9 Watt  
Power loss (Standby consumption) ≤50 mW

**Documentation**  
© smart things, Germany. All rights reserved. We accept no liability for technical or printing errors and their consequences. All trademarks and property rights are acknowledged. Changes in the sense of technical progress may be made without prior notice.





